

The Low Temperature Heat Recovery in Industry: Which Potential and How to Access It?

Maxime Dupont and Eugenio Sapora, EDF R&D

ABSTRACT

In French industry, about 75% of final energy use is for thermal purposes (furnaces, reactors, boilers, dryers). The most important part of that heat is produced through fossil fuels generating large CO₂ emissions. Unfortunately, some studies estimate that some 30% of the final energy used for thermal purposes is wasted through heat losses. In order to achieve the energy-efficiency and CO₂ goals of the European energy climate package (20% less energy consumptions and CO₂ emissions in 2020), the heat has to be saved, recovered and valorized.

This paper intends to provide heat recovery potentials at low temperature per industrial sector in France. The potential of heat pump systems will then be evaluated in terms of energy savings, avoided CO₂ emissions and additional electricity sales.

As the potential is important, EDF R&D decided (1) to invest in the development of a heat-pump prototype and (2) to start further researches to make it capable to reach higher condensing temperature and pressure than any other equipments already on the market. That improvement will allow to target some industrial sectors that were not yet accessible for current heat-pump systems due to the temperature level of the energy uses. The second objective of that paper¹ is to describe the prototype, the experiments realized and the results already available.

Introduction

Europe is now committed on its energy policy for 2020 and further. Among other objectives, the European Union shall reduce its own CO₂ emissions and energy consumption and increase the proportion of renewable energies in its energy mix by at least 20%.

In industry, about 75% of the final energy use is for thermal purposes (furnaces, reactors, boilers, dryers etc...). The major part of that heat comes from the combustion of fossil fuels generating large CO₂ emissions. Unfortunately, some studies estimate that around 30% of the final energy used for thermal purposes is wasted through losses!

In industry, only few measures are eligible to white certificates¹ in France. Boiler economizers and variable speed drives (VSD) are the main implemented measures because of their high saving potential and quite simple implementation. On the opposite, more complex measures such as heat recovery on industrial processes is not yet rewarded because energy savings they generate can hardly be estimated ex-ante.

¹ The incentive “white certificate” mechanism gives mandatory energy saving objectives to energy suppliers on a 3-year period and checks at the end whether or not the supplier reached the objectives. If the supplier failed, he has to pay a penalty proportional to the gap of energy savings. The main characteristic of that mechanism is that energy savings are estimated ex-ante and then standardized to avoid measurement and verification costs. For example, in average, to make one household invest in a condensing boiler allow him to save (in comparison to the averaged boiler with lower efficiency) a certain amount of energy that varies with the climate zone of the housing. The supplier is then rewarded with that amount of energy savings and, by adding a lot of actions, can reach his overall saving target.

However, in order to achieve our goals, the action to save energy by recovering and using the waste heat should be promoted and supported. This paper intends to deal with the opportunities and the potential of heat recovery at low-temperatures.

Industrial Waste Heat Recovery through Heat Pumps

Principles of a Heat Pump Systems

A heat pump must be set-up between two heat sources at different temperatures. The temperature of the “cold source” must be higher than the evaporating temperature of the refrigerant. The temperature of the “hot source” must be lower than the condensing temperature of the refrigerant. A heat pump recovers heat from the cold source to use it at higher temperature. In order to ensure both cost effectiveness and energy efficiency, the cold source has to be non directly usable for another usage and either renewable or free or wasted.

Figure 1. Principles of heat pump systems

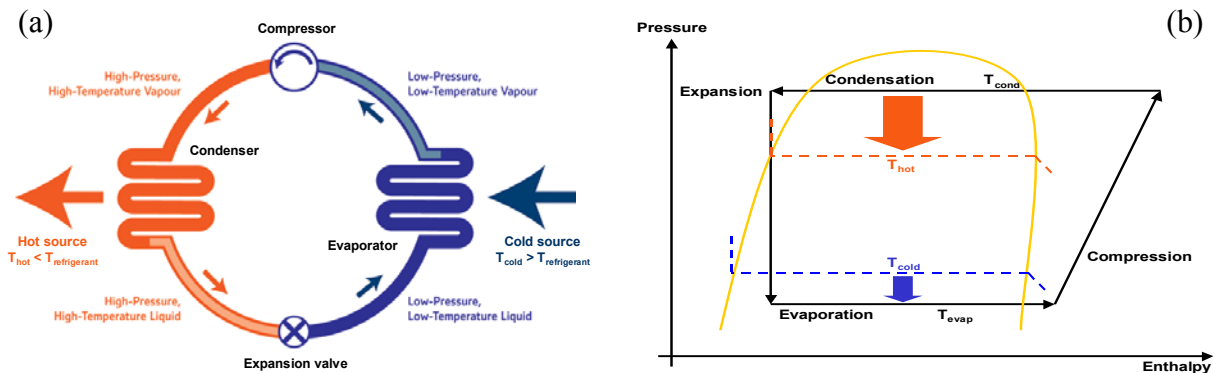

The principles of a heat pump system is presented in the Figure 1. The different steps of the thermodynamic cycle are:

- the refrigerant, in a low pressure liquid phase, receives heat from the cold source and evaporates at a constant pressure;
- the refrigerant in a low pressure gas phase is compressed. The mechanical work W (W) provided by the compressor increases its pressure until the condensing pressure, its temperature and then its enthalpy;
- the refrigerant, in a high pressure gas phase, releases heat P_{cond} (W) to the hot source and then condensates at a constant pressure;
- expansion at constant enthalpy brings the refrigerant back to its low pressure liquid phase.

The instantaneous value of the coefficient of performance (COP) of such a thermodynamic cycle is:

$$COP = P_{cond} / W \text{ (Eq 1).}$$

Technical Hypotheses

In order to simplify calculations and ensure a better understanding of the paper, few assumptions are made :

- No-loss compressor : the mechanical work W (W) provided by the compressor to the refrigerant is equal to its electrical input power P_{elec} (W);
- No-loss heat transfers : the heat released by the refrigerant is equal to the heat demand P_{hot} (W) of the industrial usage behind the condenser;
- COP will be considered as an averaged value during the year. For a year, Q (kWh/yr) is the heat provided by the heat pump to the heat source and E (kWh/an) is the energy used the heat pump. Therefore, the equation 1 becomes $COP=Q/E$ (Eq 2).

Heat Pump Integration Examples

In order to supply heat over 100°C , a heat pump cannot recover heat from outside air or ground as in the building sector. In our previous paper (Dupont & Sapora, 2009), some typical (air-compressors, chiller condensers, clean-in-place) industrial heat sources ($35\text{-}70^{\circ}\text{C}$) were listed. Other typical heat sources and integration example exist (Sapora, Bobelin & De Larminat, 2011).

For example, in Figure 2a, the heat pump recovers heat from the moist air of dryers in a paper production plant and re-heat to fresh air until $90\text{-}110^{\circ}\text{C}$ (depending on the type of paper).

Figure 2. Example of Heat Pump Integration in Industry

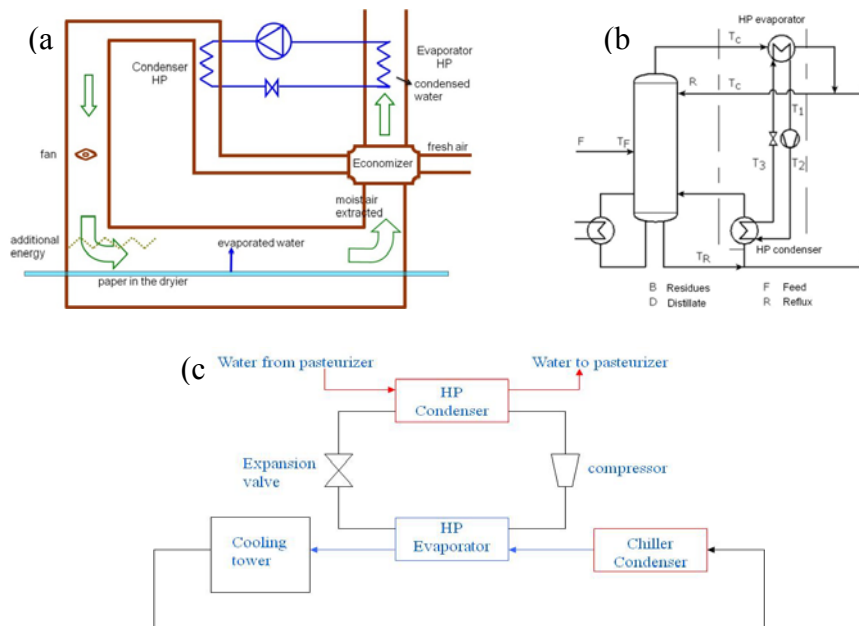

In Figure 2b, the heat pump recovers heat on distilled vapors from a distillation columns in a chemical site and contributes to heating in the distillation column until $75\text{-}130^{\circ}\text{C}$ (typical range of most applications but depending on the product to distillate).

Finally, on Figure 2c, the heat pump recovers heat at the condenser of a chiller to re-heat the water used in common pasteurizers in food and beverage industries (milk, cream, fruit juice, beer...) around 75-100°C.

Calculation of the Heat Recovery Potential

Characterizing Market Segments

Survey. The paper is based on a survey concerning the use of heat at low temperature (0-200°C) in the French industry. This survey is divided into market segments MS_{ijk} is characterized by a sector i , a usage j and a temperature level k . The survey has been made on the basis of the previous French classification².

Considered branches. For that paper, we used the current European classification³ but considered only nine industrial branches including around 40 sub-sectors: dairy products (10.5³), sugar (10.81³), other food products and beverages (10+11-10.5-10.81³), basic iron, steel and ferro-alloys (24.1³), cement, lime and plaster (23.5³), rubber and plastic products (22³), other basic organic chemicals (20.1 + 20.2 + 20.4³), terrestrial transport equipments (29.1 + 29.2 + 29.3 + 30.2 + 30.9³) and paper and paper products (17³). These 9 branches use 70% of the overall industrial heat at 60-200°C .

Considered usages. Inside these 9 branches, only 6 energy usages were considered: “Drying”, “Evaporating, concentrating and crystallizing”, “Liquid and gas heating”, “Distillation”, “Thermal treatment” and “Chemical reaction”. Together, they use almost 90% of the overall industrial heat at 60-200°C .

Considered temperature levels. There are 9 temperature levels: 60-69°C, 70-79°C, 80-89°C, 90-99°C, 100-119°C, 120-139°C, 140-159°C, 160-179°C and 180-199°C. Theoretically, our survey accounts 2160 market segments (6 usages at 9 temperature levels in 40 sub-sectors). However, for that paper, we only focus on temperatures under 140°C that we think more accessible to heat pump systems after some investments in research and development. Finally, 1440 market segments are considered but, on the field, only around 710 demand heat.

Data. On each market segment, the survey provides the heat used Q_{ijk} (kWh/year), the installed overall heating capacity ΣP_{ijk} (kW) and the number of heating equipments N_{ijk} . The averaged heating unit capacity P_{ijk} per market segment is then $P_{ijk} = \Sigma P_{ijk} / N_{ijk}$ (Eq 3).

Theoretical Potential of Heat-Pump Systems

The potential of heat pump systems in industry will be characterized by 3 indicators: energy savings, additional electricity sales and avoided CO₂ emissions. These indicators can be calculated on each market segment. They will then be qualified of “theoretical” because the

² NAF 2003 now replaced by NAF 2008

³ NACE rev2

substitution of current heating system by heat pumps is systematically considered as technically and economically feasible.

Additional electricity sales. Satisfy the heat demand Q_{ijk} of each market segment through heat pumps requires additional electricity consumptions E_{ijk} . Using the previously defined assumptions, the latter can be calculated by:

$$E_{ijk} = \frac{Q_{ijk}}{COP_{ijk}} \quad (\text{Eq 4})$$

Sectors, usages and temperature levels are very diverse in industry. Operating conditions of one heat pump and then its COP can change through time and from one market segment to another. Therefore, for that paper we made the assumption of an averaged COP independent of the market segment and operating conditions so that equation 4 becomes $E_{ijk} = Q_{ijk} / COP$.

The overall additional electricity consumptions for the whole industry E is the sum of on every market segments, $E = \sum E_{ijk} = \sum Q_{ijk} / COP = Q / COP$. Q (Eq 5) represents the overall heat demand at 60-200°C of the French industry. The overall additional electricity sales are estimated at 11,1 TWh/year by assuming a COP equal to 3.

Energy savings. On each market segment, energy saving ES_{ijk} (kWh/year) are generated through the substitution of current heating systems (direct heating or indirect through a boiler) by heat pump systems recovering waste heat on-site to satisfy the heat demand Q_{ijk} (kWh/year). With previously defined assumptions, energy savings can be calculated for each market segment by:

$$ES_{ijk} = Q_{ijk} - E_{ijk} = Q_{ijk} \left(1 - \frac{1}{COP} \right) \quad (\text{Eq 6})$$

Figure 3. Theoretical Energy Savings per Sector and Temperature Range

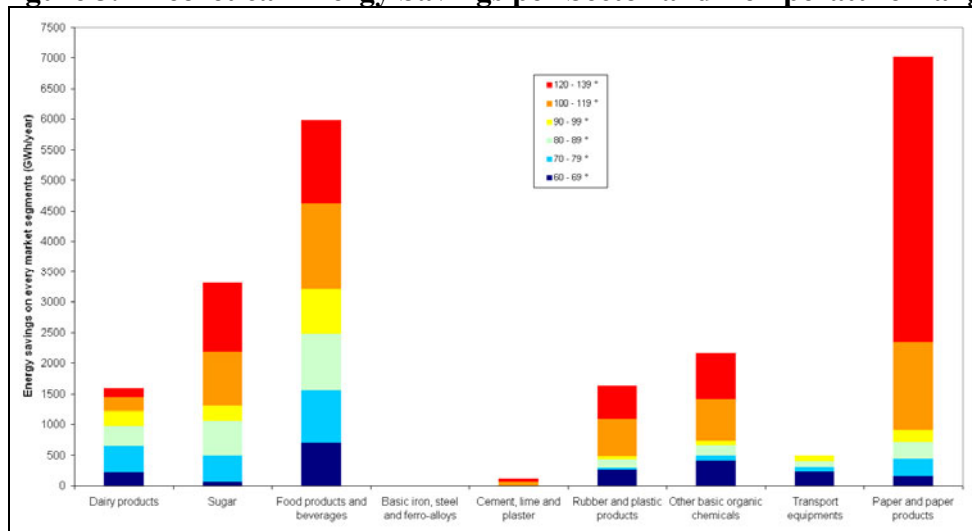

The overall energy savings for the whole industry is then the sum of on every market segments, $ES = \sum ES_{ijk}$ (Eq 7). By assuming a COP equal to 3, the overall energy savings on every market segments are estimated at 22.3 TWh/year. The shares between branches and temperature levels are presented in the Figure 3. Energy savings are theoretically important in

food and beverage but also in paper and paper products sectors. However, in paper and paper products sectors, energy savings will be achievable only if heat pumps are capable to supply heat over 100°C.

Avoided CO₂ emissions. Substituting fossil fuel heating by electrical heat-pump systems would avoid CO₂ emissions in France due to the low emission factor of electricity EEF (gCO₂/kWh). The precise avoided CO₂ emissions depend on the heating systems energy mix in each market segment. In that paper, we make the simplifying assumption that, in average, industrial heating systems use natural gas with the emission factor NGEF (kgCO₂/kWh LHV⁴).

$$\Delta\text{CO}_2_{ijk} = Q_{ijk} \cdot \text{NGEF} - E_{ijk} \cdot \text{EEF} = Q_{ijk} \left(\text{NGEF} - \frac{\text{EEF}}{\text{COP}} \right) \quad (\text{Eq 8})$$

The aim of the paper is to prove the interest of such a system at a national level Therefore we chose to consider overall CO₂ emissions including CO₂ emitted on-site (combustion) and on every step of the supply chain (production/extraction, transport, distribution). NGEF is then 232 gCO₂/kWh LHV and EEF is 55 gCO₂/kWh.

The overall avoided CO₂ emissions for the whole industry is then the sum of on every market segments, $\Delta\text{CO}_2 = \Sigma\Delta\text{CO}_2_{ijk}$ (Eq 9). The overall avoided CO₂ emissions on every market segments are estimated at 7140 ktCO₂/year. As emission factors are independent of temperature levels and sectors, the share of avoided CO₂ emissions is the same as in Figure 3.

Accessible Potential of Heat Pump Systems

Methodology

The potentials are considered as “accessible” when they are technically and economically achievable. They will be calculated using a “filtering” of every market segments to keep only them for which the heat pump system implementation is technically feasible and cost-effective.

Technically Eligible Market Segments

The theoretical potential will never be reached. Some technical constraints will restrict the systematic implementation of heat pump systems. Any constraint can be taken into account. In that paper, we chose to filter market segments with a capacity criteria.

Indeed, although tailored high capacity heat pumps can be manufactured, the unit heating capacity of existing standard heat pumps is limited. As thermodynamic systems generally require large initial investments, the installation in parallel of several high capacity heat pumps to supply heat for one usage is not economically rational. Therefore, the heating capacity P_{ijk} on each market segment has to be compatible with the heat pump market. We assume the maximum heating capacity C_{max} of available heat pumps is 5 MW. Technically eligible market segments are them for which their own heat demand Q_{ijk} can be satisfied by a heating capacity $P_{ijk} < C_{\text{max}}$.

The overall energy savings (summed only on technically eligible market segments) are 5.4 TWh/year. The shares between branches and temperature levels are presented in the Figure 4.

⁴ Lower heating value

Energy savings remain important in food and beverages sectors. However, in sugar and paper industries, energy savings are much lower because they require large heating capacities and finally become ineligible.

Figure 4. Energy savings on technically eligible market segments

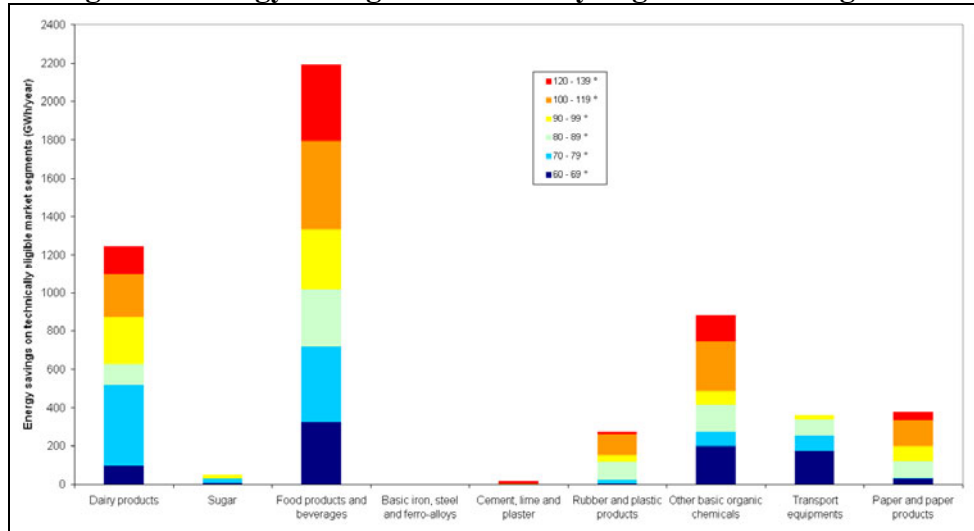

Additional electricity sales and avoided CO₂ emissions are estimated respectively at 2.7 TWh/year and 1336 ktCO₂/year. As C_{max} is independent of the sector and temperature level, their share between sector and temperature is the same as in Figure 4. The filtering by the capacity is very selective but the influence of C_{max} will be tested in the sensibility study.

Economically Eligible Market Segments

Investment costs. The components of heat pumps and chillers are the same. We make the assumption that, for a similar cooling/heating capacity, their investment costs are the same.

Figure 5. Investment and Installation Costs of Heat Pump Capacity

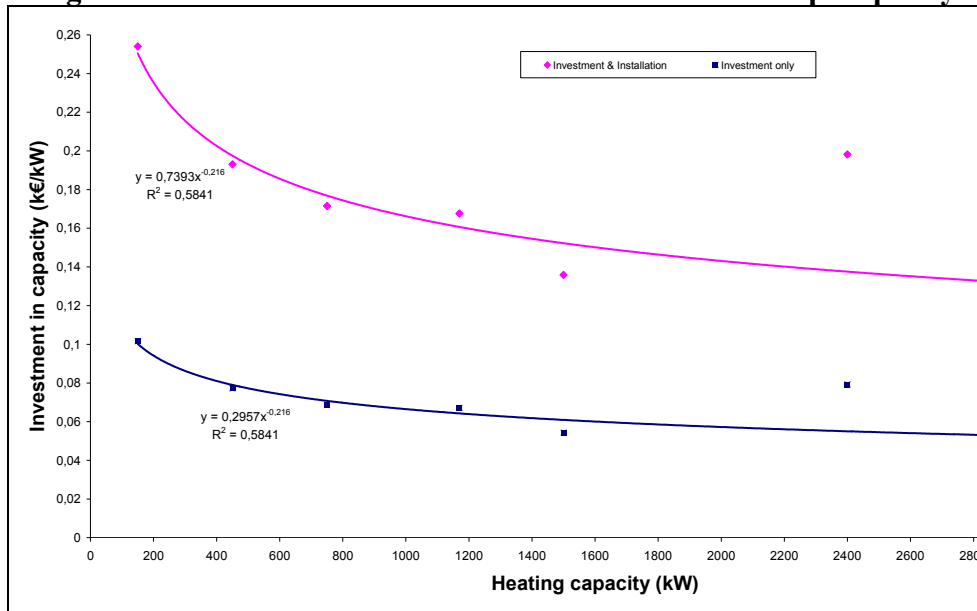

However, as current technologies are not capable yet to supply heat at 140°C. EDF R&D and some partners in Europe make research in order that heat pump systems be able to reach that temperature level. Then we consider that this kind of new systems will require 20% additional investment costs.

Finally, the set up of the heat pump on site is often a costly phase. EDF experts consider that the investment cost is doubled if installation is included. The

Figure 5 presents the investment costs I (k€/kW) of such a heat pump system.

Investment and installation costs IC_{ijk} (k€) can be calculated on each market segment by multiplying the needed capacity ΣP_{ijk} to the unit cost of the capacity I .

Operation cost savings. The substitution of current heating systems using fossil fuels by heat pump systems using electricity generate the operation costs savings ΔOC_{ijk} . The latter are calculated by the difference between operation costs of respectively natural gas systems $NGOC_{ijk}$ and electrical heat pumps EOC_{ijk} using electricity prices pe_{ijk} and natural gas png_{ijk} :

$$\Delta OC_{ijk} = NGOC_{ijk} - EOC_{ijk} = Q_{ijk} png_{ijk} - E_{ijk} pe_{ijk} = Q_{ijk} \left(png - \frac{pe}{COP} \right) \quad (\text{Eq 10})$$

For that paper, we used an average price for both energies in France because knowing exactly the prices in each market segment was too difficult. The main drawback of that assumption is that an “averaged” industrial client pays an averaged price for the natural gas and an averaged price for the electricity. This is not the case in reality because the client can be a large natural gas user and a small electricity (or the opposite) so that tariffs can be much more different.

The

Table 1 sums-up the price hypotheses. Finally, heat pump systems will generate operation cost savings only if $p_{ng}/p_e > 1/\text{COP}$.

Table 1. Energy Prices in France

	Electricity Contract – Average customer – Tariff	Natural gas Contract – Average customer – Tariff
Small Industry	“Vert A5” (1 GWh/year) 67,2 € ET ⁵ /MWh	“B2S” (1,3 GWh HHV ⁶ /year) 45,6 € ET/MWh LHV
Medium Industry	“Vert A8” (10 GWh/year, 10 MW, 2000 h/year) 53,1 € ET/MWh	“TEP” (13 GWh HHV/year) 51,2 € ET/MWh LHV
Large Industry	“Vert B” (100 GWh/year, 10 MW, 5000 h/year) 40,6 € ET/MWh	“STS” (130 GWh HHV/year) 47,5 € ET/MWh LHV
Average	53,6 € ET/MWh	48,1 € ET/MWh LHV

Source: EUROSTAT 2009

Cost-efficient potential. The cost-effectiveness criteria is the payback time PT_{ijk} (year) simply calculated as the ratio between the investment costs IC_{ijk} (€) and the operation cost savings ΔOC_{ijk} (€/year):

$$PT_{ijk} = \frac{IC_{ijk}}{\Delta OC_{ijk}} \quad (\text{Eq 11})$$

For that paper, we consider that the implementation of heat pump systems on a technically eligible market segment is cost-effective when $PT_{ijk} < PT_{max}$. In a first step, PT_{max} is 2 years.

Figure 6. Energy Savings on Economically Accessible Market Segments

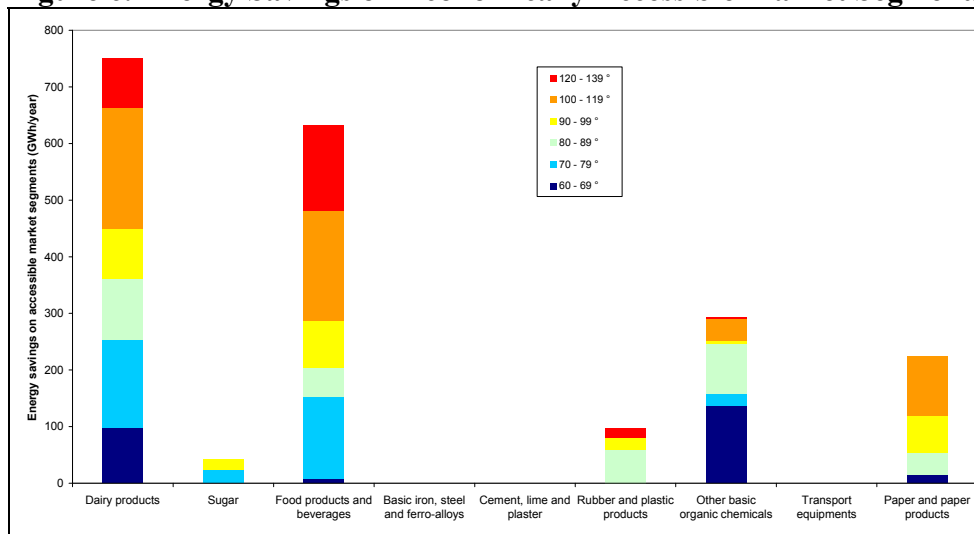

The accessible (summed only on technically and economically eligible market segments) energy savings are 2 TWh/year. The shares between branches and temperature levels are presented in the Figure 6. Energy savings are always important in food and beverage except sugar which is a seasonal activity in France. Accessible additional electricity consumptions and avoided CO₂ emissions are estimated respectively at 1 TWh/year and 650 ktCO₂/year. As the

⁵ Excluded taxes

⁶ Higher heating value

COP is independent of the sector and temperature level, their share between sector and temperature is the same as in Figure 6. Finally, the filtering by the payback time is very selective but the influence of PT_{max} will be tested in the sensibility study.

Sensitivity Study

Influence of Main Parameters

The influence of the main parameters (energy prices, available heat pump maximum capacity and tolerated payback time) of our study on accessible energy savings is briefly presented in the Table 2. The note under the table sums-up the reference parameters. These parameters have only consequences on the calculation of accessible potentials but theoretical potentials are not changed.

The sensitivity of accessible potentials to maximum heat pump capacity is quite high. A slight variation can (dis)qualify a lot of market segments especially in paper industry, dairies and food products and beverage. Market segments in other branches were already largely disqualified by reference parameters.

The influence of energy prices is less sensible on accessible potentials. The electricity price have more influence than the natural gas price. However, instead of natural gas, industrial sites use large amounts of other fuels for heating purposes and their prices can be less stable with time.

Industrials accept important investments on their production process with long payback time motivated by productivity and competitiveness improvements. Their tolerance against the payback time for pure (only motivated by energy and money savings criteria) energy efficiency investments is generally much lower. A payback time of 4 years instead of 2 years increases of 25% the accessible energy savings. This could be achieved through a combination of energy awareness raising and more incentives from public authorities.

Table 2. Sensitivity of Accessible Savings to Main Parameters

Influence of → that varies of → at →	Natural Gas price png		Electricity price pe		Maximum capacity C_{max}		Payback time PT_{max}	
	+10%	+21%	+10%	+21%	-40%	+40%	+50%	+100%
	53	58	58	64	2	8	3	4
Dairy products	-	-	16%	27%	-75%	-	-	-
Sugar	-	-	-	-	-100%	-	-	15%
Food products and beverages	9%	18%	-5%	-5%	-81%	39%	27%	30%
Basic iron, steel and ferro-alloys	-	-	-	-	-	-	-	-
Cement, lime and plaster	-	-	-	-	-	-	-	-
Rubber and plastic products	-	-	-	-	-96%	-	4%	4%
Other basic organic chemicals	4%	48%	-2%	-3%	-71%	117%	58%	89%
Terrestrial transport equipments	-	-	-	-	-	-	-	-
Paper and paper products	11%	11%	-47%	-47%	-93%	189%	12%	12%
Average	5%	14%	-13%	-17%	-80%	50%	19%	25%

Reference : $C_{max}=5$ MW, $PT_{max}=2$ years, COP=3, $pe=58\text{€ ET/MWh}$, $png=48\text{€ ET/MWh LHV}$

Influence of the Heat Pump Performance

The heat pump COP is the only parameter that influences the calculation of theoretical potentials and thus of accessible potentials (Table 3). The effect of a COP variation is totally symmetric on theoretical potentials because neither technical nor economical constraints are considered. However, some market segments can become cost-effective (respectively cost-ineffective) with a small increase (respectively decrease) in COP. This threshold effect is due to our all-or-nothing calculations on market segments and quite accentuated by the results in percentages.

Table 3. Sensitivity of Potentials to the Heat Pump COP

Influence on →	Theoretical savings		Accessible savings		Accessible electricity oversales		Accessible avoided CO ₂ emissions	
	-33%	+33%	-33%	+33%	-33%	+33%	-33%	+33%
of a COP variation of →	2	4	2	4	2	4	2	4
meaning of COP of →	2	4	2	4	2	4	2	4
Dairy products	-25%	13%	-89%	13%	-79%	-25%	-86%	2%
Sugar	-25%	13%	-67%	13%	-34%	-25%	-58%	2%
Food products and beverages	-25%	13%	-42%	23%	17%	-18%	-25%	11%
Basic iron, steel and ferro-alloys	-25%	13%	-	-	-	-	-	-
Cement, lime and plaster	-25%	13%	-	-	-	-	-	-
Rubber and plastic products	-25%	13%	-25%	13%	50%	-25%	-4%	2%
Other basic organic chemicals	-25%	13%	-32%	16%	37%	-22%	-13%	6%
Terrestrial transport equipments	-25%	13%	-	-	-	-	-	-
Paper and paper products	-25%	13%	-63%	25%	-27%	-16%	-53%	14%
Average	-25%	13%	-60%	18%	-20%	-21%	-49%	7%

Reference : $C_{max}=5$ MW, $PT_{max}=2$ years, $COP=3$, $pe=58€$ ET/MWh, $png=48€$ ET/MWh LHV

A decrease in the heat pump COP benefits in theory to electricity suppliers because for a same service, heat pumps will use more electricity. However, the number of accessible market segments is much lower too.

EDF R&D Experiments

The Heat Pump Prototype

EDF R&D is testing a heat pump provided by Johnson Controls and designed to provide up to 450 kW with HFC-245fa at 100°C (Sapora, Bobelin & De Larminat, 2011). It is a water to water electrically-driven heat pump with capacity modulation, including:

- a double screw oil injected compressor with variable volume ratio and variable speed drive;
- a shell and tube condenser with integrated subcooler;
- a dry expansion shell and tube evaporator;
- an electronic expansion valve.

A super-heating heat exchanger (between the compressor and the evaporator) prevent the refrigerant against condensation at the end of the compression due to the highly inclined saturation curve of R245fa (example of curve in Figure 1).

Performances

The testing protocol is described in details Sapora, Bobelin & De Larminat, 2011. The promising performances of the prototype are presented in Figure 7.

Figure 7. Performances of the EDF Heat Pump Prototype

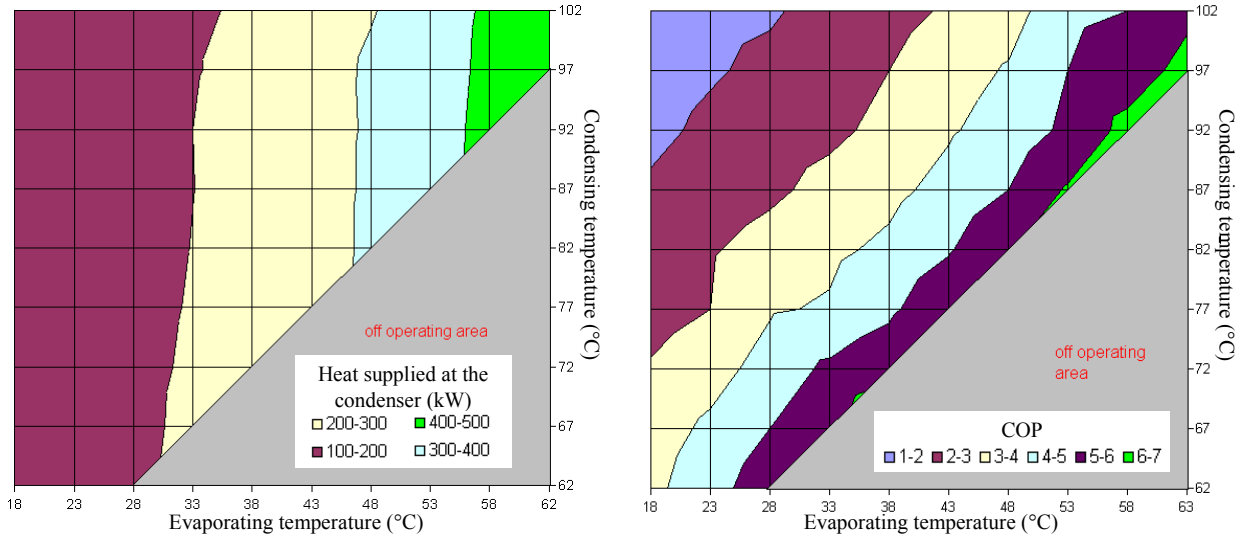

Source: Sapora, Bobelin & De Larminat, 2011

The operating temperatures (102°C for condensation and 63°C for evaporation) are limited by the design of heat exchangers for that experiment but the compressor can, in theory, operate at much higher temperature.

Conclusion

By assuming the availability of a heat pump capable of supplying heat until 140°C with a COP of 3, its systematic implementation in industry for waste heat recovery could lead to:

- accessible savings of 2 TWh/year;
- additional sales for electricity suppliers of 1 TWh/year ;
- and avoided CO₂ emissions of 650 ktCO₂/year.

45% of these accessible potentials are achievable on the range 60-90°C by slightly improved existing heat pump systems. The other 55% of the potentials require more researches and developments (especially in refrigerants) to be able to operate on the range 90-140°C.

These accessible potentials are sensible to our hypothesizes:

- +1 unit of COP increases of 18% accessible energy savings and decreases of 21% the additional electricity sales and of 7% the CO₂ emissions ;

- a 40% decrease in the capacity of heat pump available on the market decreases of 80% the accessible potentials;
- a 21% increase in electricity prices (respectively in natural gas prices) decreases (respectively increases) the accessible potentials of 15%;
- a accepted payback time of 4 years instead of 2 years increases of 25% the accessible potentials;

The prototype in which EDF R&D invested provides promising results especially in terms of performances. Indeed, recovering at 40-65°C to supply heat at 100°C can be done by the prototype with a COP between 3 and 7. The potentials of waste heat recovery through heat pump systems in industry could finally be much higher than expected...

References

- Dupont, M., Sapora, E. 2009. **The Heat Recovery Potential in the French Industry: Which Opportunities for Heat Pump Systems?** ECEEE Summer Study Proceedings, ISBN: 978-91-633-4454-1, p.1115-1123
- Sapora, E., Bobelin, D., De Larminat, P. 2011. **Experimental Investigation of a High Temperature Heat Pump Using Hfc-245fa as Working Fluid for Heat Recovery in Industry.** 10th IEA Heat Pump Conference, 16-19 May 2011, Tokyo, Japan