

**Energy Efficiency**  
**in the**  
**Metals Fabrication Industries**

David A. Michaelson, P.E., The Boeing Company  
Dr. F. T. Sparrow, Ph.D., Purdue University

*Prepared for the ACEEE 1995 Summer Study on Energy Efficiency in Industry  
Grand Island, New York, 1-4 August 1995*

**Contents**

**ENERGY EFFICIENCY IN THE METALS FABRICATION INDUSTRIES**

INTRODUCTION  
THE DIFFERENT VIEWPOINTS

**CHAPTER 1 ENERGY EFFICIENCY, PAST PRESENT AND FUTURE**

PART 1 - HISTORY OF ENERGY MANAGEMENT IN INDUSTRY  
PART 2 - CURRENT MARKET CONDITIONS  
PART 3 - ANSWERS

**CHAPTER 2 - THE PLANT ENERGY MANAGER**

PART 1 - INTRODUCTION  
PART 2 - QUALIFICATIONS  
PART 3 - FUNCTIONS (WHAT DOES THE ENERGY MANAGER REALLY DO?)  
PART 4 - OPPORTUNITIES

Lighting Systems  
HVAC Systems  
Steam systems  
Cooling Water  
Compressed Air and Vacuum  
The Manufacturing Process

PART 5 - UTILITY BILLINGS

Special Contracts  
Electricity  
Power Factor  
Heating Fuels  
Water and Sewer  
Solid Waste

PART 6 - TACTICS

Communications  
Selling a Project

PART 7 - SPECIAL CONSIDERATIONS

Availability of resources  
Schedule

Code, Regulation and Environmental Requirements  
Fabrication and Manufacturing Requirements  
Maintenance Issues and Product or System Life  
People and Safety Concerns

PART 8 - SUMMARY

### **CHAPTER 3 - EXTERNAL INFLUENCES**

PART 1 - GENERAL

PART 2 - ENERGY POLICY ACT OF 1992

PART 3 - THE EPA GREEN LIGHTS PROGRAM

PART 4 -EPA'S ENERGY STAR BUILDINGS PROGRAM

PART 5 - MOTOR CHALLENGE PROGRAM

PART 6 - DEMAND SIDE MANAGEMENT

PART 7 - SUMMARY

### **CHAPTER 4 - PROJECTING ENERGY END USE**

PART 1 - INTRODUCTION

PART 2 - THE METHODOLOGY

*Energy Use Characteristics of the Metals Fabrication Industries*  
*AN EXAMPLE ANALYSIS -- SIC 3714*

PART 3 - SUMMARY

### **CHAPTER 5 - WORKING TOGETHER**

**CASE STUDY: BOEING'S LONGACRES CUSTOMER SERVICES TRAINING CENTER**

**BIBLIOGRAPHY**

# Energy Efficiency in the Metals Fabrication Industries

David A. Michaelson, P.E., The Boeing Company  
Dr. F. T. Sparrow, Ph.D., Purdue University

## Introduction

This paper has been developed to cover industrial energy conservation and energy efficiency<sup>1</sup> related topics as they pertain to the Metals Fabrication Industries (SIC's 34 through 37)<sup>2</sup>. It was also developed as a guide on energy management programs for the plant energy manager. This portion of the paper is not intended to be all encompassing, but is intended to give the individual a "How To..." look at starting and maintaining an effective energy management program, as well as a look at some of the factors which can influence an energy management program.

The SIC's chosen for this paper include 34 - Fabricated Metal Products, 35 - Industrial & Commercial Machinery and Computer Equipment, 36 - Electronic & Electrical equipment except computer equipment, and 37 - Transportation Equipment. Each of these groups are involved in the fabrication of metal products either as a primary business or in the development and assembly of a final product. With few exceptions, the companies represented by these SIC codes do not begin their manufacturing with raw products but rather, rely upon other companies in other SIC codes to perform the necessary refining and/or smelting of the initial raw materials into a product suitable to begin fabrication into an end product.

This paper covers a wide range of topics related to industrial energy management, including:

- Background - A brief discussion on the history of energy management, past, present and future conditions affecting energy usage, as well as a discussion on why industrial managers should be concerned about energy use.
- The Plant Energy Manager - A look at the people involved in energy management, the tools and hardware available to assist the energy manager, and the tactics used for the implementation of effective programs. This section includes a discussion on some of the factors within a company that motivate management to become active in addressing energy issues
- External Influences - What regulations and conditions are influencing companies of all sizes to become active in improving energy efficiency.
- Savings Potential - What benefit can realistically be gained by changing the manufacturing processes.

---

<sup>1</sup> Many people use the terms "energy conservation" and "increase in energy efficiency" interchangeably. For this paper, increases in energy efficiency are any actions that tend to reduce the ratio of energy use per unit of activity, be they changes in activity levels, changes in energy use or a combination of both. Energy conservation, on the other hand, is the special case of increases in energy efficiency brought about by decreasing energy use, holding units of activity constant. Using these definitions, increasing throughput to allow fixed energy costs to be spread over a larger number of units would increase energy efficiency but would not qualify as an energy conservation measure.

<sup>2</sup> Throughout this paper the acronym SIC is used to indicate Standardized Industrial Code, a means developed to categorize manufacturers into common groups.

- Working Together - A discussion on how industry, the utilities and government can work together and some of the changes that need to be made in all three.

### **The Different Viewpoints**

The two authors brought a particular perspective to the paper. As might be expected, both had a slightly differing view as to why the interest in energy efficiency. The following are the viewpoints of the co-authors.

**THE INDUSTRIAL SECTOR - DAVID MICHAELSON** The view within industry is that energy is comparatively inconsequential. Reliability of service is far more important than the cost of that service. Although billions of dollars are spent each year on utility costs, these costs are small when compared with the overall cost of manufacturing. There are a growing number of experts across the country that claim to know what is best for industry and are willing to lobby in favor of energy efficiency improvements. It is feared that unnecessary and impractical regulation could result if industry is not actively involved in energy issues and the development of regional and national energy policies. Who knows industry and the manufacturing process better than industry representatives? Who is better qualified than the industrial representative to identify which changes should be implemented and when?

More companies are finding it advantageous to present a “good neighbor” image. Industry has been viewed as an uncaring entity with massive funds and resources at its disposal. This viewpoint is shared by the public, often by the utility companies and by many within government. It is a viewpoint that is based on misconception and needs to be dispelled. By actively pursuing energy conservation a company is publicly viewed as being concerned about the local economy and general welfare of the community.

In addition to the political implications, improving energy efficiency may reduce the demand placed on utilities. This can help keep utility costs down by reducing the need for utilities to purchase more expensive peaking power. Reducing the demands placed on utilities may also increase reliability of service by reducing the likelihood of curtailment of service during periods of extremely severe weather.

**THE ACADEMIC’S VIEW - TOM SPARROW** The view of many in the academic world is that because energy prices are not “right”, energy consumption decision makers cannot be counted on to make the correct resource mix choices. In short, energy is underpriced, because of a combination of improper supply incentives, market failures, and social costs. As a result, the cost per BTU paid in the market is a poor indicator of the true cost of energy consumption to society. As a result of this underpricing, decision makers systematically underinvest in energy efficiency improving measures, since the benefits of such investments are understated.

## CHAPTER 1 ENERGY EFFICIENCY, PAST PRESENT AND FUTURE

### Part 1 - History of Energy Management in Industry

There has been very little concern for energy efficiency in the metals fabrication and related industries in the past. Plants were built, machines were purchased and manufacturing processes were developed for the purpose of manufacturing parts to be assembled into a finished product and sold on the open market. The primary concern in the development of these processes was how to make more parts for less money so the final product could be sold for less money while still providing an acceptable profit. Ideally, a product could be produced at a lower cost than the competition, and still provide a level of quality acceptable to the consumer. In the 1960's and 1970's, foreign competition became a significant factor to be contended with. In many markets, this foreign competition was able to manufacture the same type of product as U.S. manufacturers but at substantially lower costs. These lower costs were primarily due to a substantially lower labor rate. As Figure 1.1 shows, after the cost of materials, labor is the most significant cost incurred by a manufacturer in the production arena.<sup>3</sup>

As the figure would suggest, one of the areas continually attacked by plant management is labor costs. Compounding the labor cost problem was the slackening in the rate of improvement in labor productivity, particularly when compared to our larger international competitors. Figure 1.2 shows the pattern of U.S. labor productivity in recent years, along with the patterns of our competitors. As the figure shows, our labor productivity improvements have lagged behind those of our foreign competitors. It should come as no surprise, then, that as these foreign competitors gained significant portions of the U.S. market share, manufacturers in the U.S. realized a need to reduce their manufacturing costs. It was apparent to the manufacturers that they either reduce their costs or go out of business. One tactic was to off-load portions of the manufacturing process to countries with lower labor rates and fewer environmental concerns. Reducing labor costs had a real mix of consequences, ranging from labor strikes to reduced production levels and even plant closures.

The next area addressed was to improve the manufacturing process by evaluating the steps that a product undergoes during manufacture and determining which can be eliminated, which need to be kept intact and which can be improved. By increasing throughput without increasing labor required, the overall per unit costs to manufacture could be reduced. By improving the manufacturing process, direct costs and material waste can be reduced on a per unit level. Indirect costs can be reduced by improving the thermal performance of buildings, reducing energy costs, improving energy usage, and recycling manufacturing waste products. Reducing direct costs has long been a goal of virtually every manufacturer. But only recently have these same manufacturers been looking at the indirect costs (excluding labor) and trying to find ways to reduce or improve these costs.

Several factors were identified which could help reduce the direct costs. First was the process itself. Is the current process the only way the product can be manufactured? Can several of the steps required be combined into a single step? Manufacturers realized they did not have the resources to answer these questions. This same condition was identified by many consultants and institutions. The result has been an explosion of energy consultants, efficiency experts and specialized departments at many major universities. Table 1.1 lists a number of universities which provide related services to the manufacturing industry.

One of the next areas addressed was in automation of the manufacturing processes to reduce the labor required to produce a part. Although the automotive industry has long been a proponent of automation and production line work, many companies within other related SIC's did not embrace automation until the advent of sophisticated electronic controls which could assure repeatability in production of similar parts with very little variation and with a reduction in labor required to produce those same parts. Figures 1.3 and 1.4 appear to support this. Figure 1.3 shows the employment history for all manufacturers. Note the trendline shows a leveling off of employment from the mid-70's to the early 80's followed by a gradual decline in employment levels into the 90's. Figure 1.4 includes the employment history for SIC's 34 through 37 and clearly indicates the growth of the electronics industry in the mid-80's. The growth of the electronics industry combined with a leveling off in the employment

---

<sup>3</sup> Annual Survey of Manufacturers, 1991, M91(AS)-1

**Figure 1.1 - Manufacturing Costs  
(Billions of Dollars)**

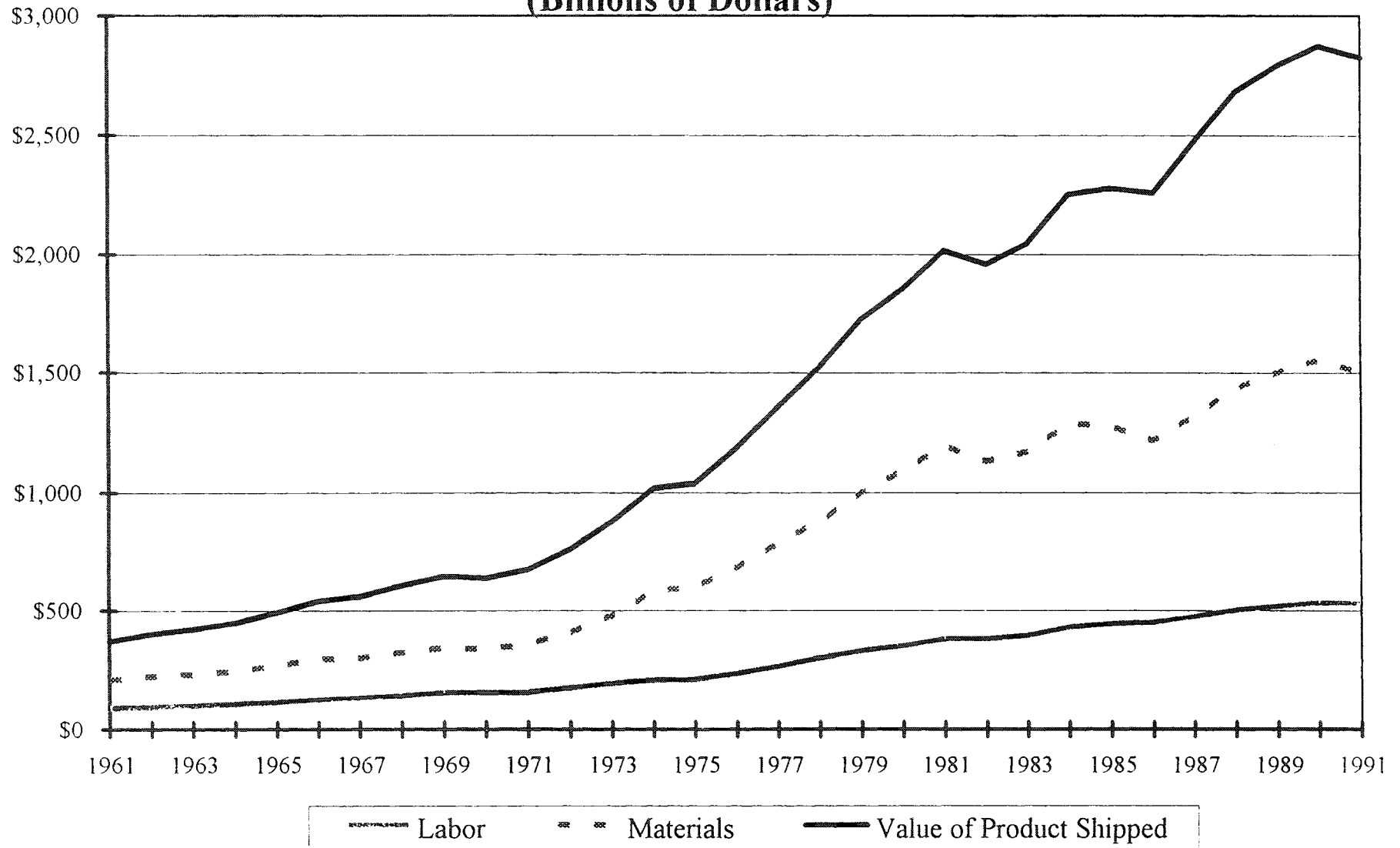

Source: 1991 Annual Survey of Manufactures, M91(AS)-1  
U.S. Department of Commerce

**FIGURE 1.2**  
**RECENT TRENDS IN LABOR PRODUCTIVITY**  
**(1960-1993)**

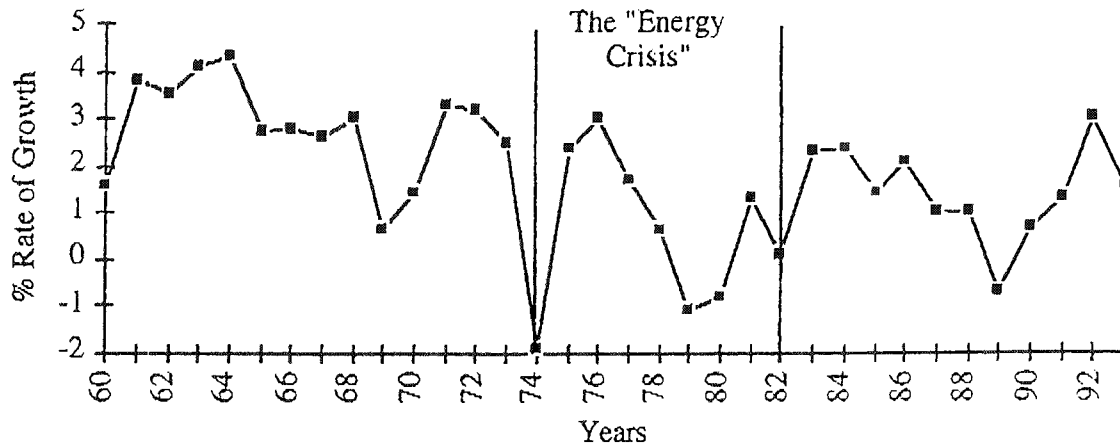

Source: EROP (95), Table B-48.

- There appears to be a relation between productivity growth and the energy situation.
- 1977-1982 productivity growth was disappointingly slow: Germany's output per person grew 5.3% in the 1967-1973 period; Japan's grew at 11.4%. Not surprisingly, U.S. share of world trade fell from 30% in the mid-1950s to 13% (Faruqui, EPRI EA-4067, p. 1-4).
- This short-term trend in productivity loss has been reversed in recent years.

Table 1.1 - Energy Analysis and Diagnostic Centers

University	City	State	Contact Name	Phone
Arizona State University	Tempe	Arizona	Dr. Byard Wood	(602) 965-2896
University of Arkansas at Little Rock	Little Rock	Arkansas	Mr. Burton Henderson	(501) 569-8224
San Diego State University	San Diego	California	Dr. Halil Guven	(619) 594-6329
San Francisco State University	San Francisco	California	Dr. Ahmad Ganji	(415) 338-7736
Colorado State University	Fort Collins	Colorado	Dr. C. Byron Winn	(970) 491-6558
University of Florida	Gainesville	Florida	Dr. Barney Capehart	(904) 392-1464
Georgia Institute of Technology	Atlanta	Georgia	Mr. William Meffert	(404) 894-3844
Bradley University	Peoria	Illinois	Dr. Paul Mehta	(309) 677-2754
University of Notre Dame	Notre Dame	Indiana	Dr. John Lucey	(219) 631-7381
Iowa State University	Ames	Iowa	Dr. Howard Shapiro	(515) 294-1323
University of Kansas	Lawrence	Kansas	Mr. Brian Burke	(913) 864-4380
University of Louisville	Louisville	Kentucky	Dr. James Watters	(502) 852-7860
University of Maine	Orono	Maine	Mr. Scott Dunning	(207) 581-2349
University of Massachusetts	Amherst	Massachusetts	Dr. Lawrence Ambs	(413) 545-2539
University of Michigan	Ann Arbor	Michigan	Dr. Arvind Atreya	(313) 747-4790
Mississippi State University	Mississippi State	Mississippi	Dr. B. K. Hodge	(601) 325-7315
University of Missouri-Rolla	Rolla	Missouri	Dr. Burns Heglar	(314) 341-4718
University of Nevada-Reno	Reno	Nevada	Dr. Robert Turner	(702) 784-1412
Hofstra University	Hempstead	New York	Dr. Charles Forsberg	(516) 463-5547
North Carolina State University	Raleigh	North Carolina	Dr. James Leach	(919) 515-5228
University of Dayton	Dayton	Ohio	Dr. Henry Chuang	(513) 229-2997
Oklahoma State University	Stillwater	Oklahoma	Dr. Wayne Turner	(405) 744-6055
Oregon State University	Corvallis	Oregon	Dr. George Wheeler	(503) 737-2515
South Dakota State University	Brookings	South Dakota	Mr. Kurt Bassett	(605) 688-4817
University of Tennessee	Knoxville	Tennessee	Dr. Richard Jendrucko	(615) 974-5355
Texas A&M University	College Station	Texas	Dr. Warren Heffington	(409) 845-5019
Texas A&M University-Kingsville	Kingsville	Texas	Dr. Yousri Elkassabgi	(512) 595-2293
Old Dominion University	Norfolk	Virginia	Dr. Sidney Roberts	(804) 683-3726
West Virginia University	Morgantown	West Virginia	Dr. Ralph Plummer	(304) 293-4607
University of Wisconsin	Milwaukee	Wisconsin	Dr. Umesh Saxena	(414) 229-4052



**Figure 1.3 - Industrial Employment History  
(Thousands)**

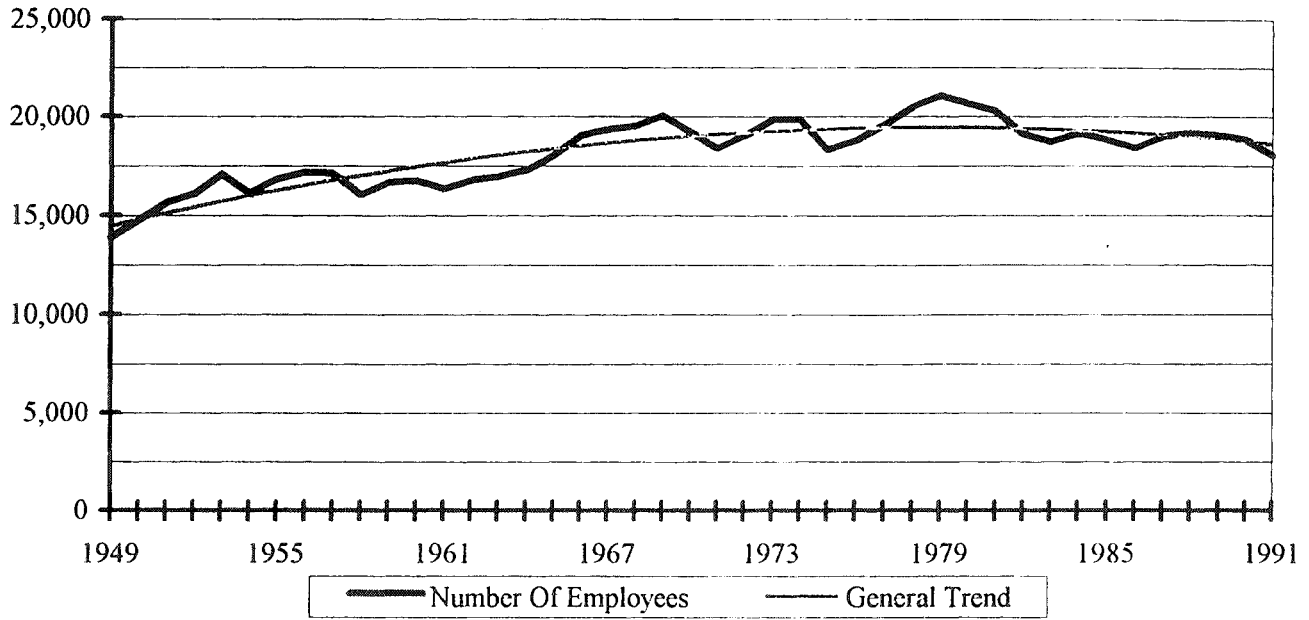

**Figure 1.4 - Industrial Employment History  
(Millions)**

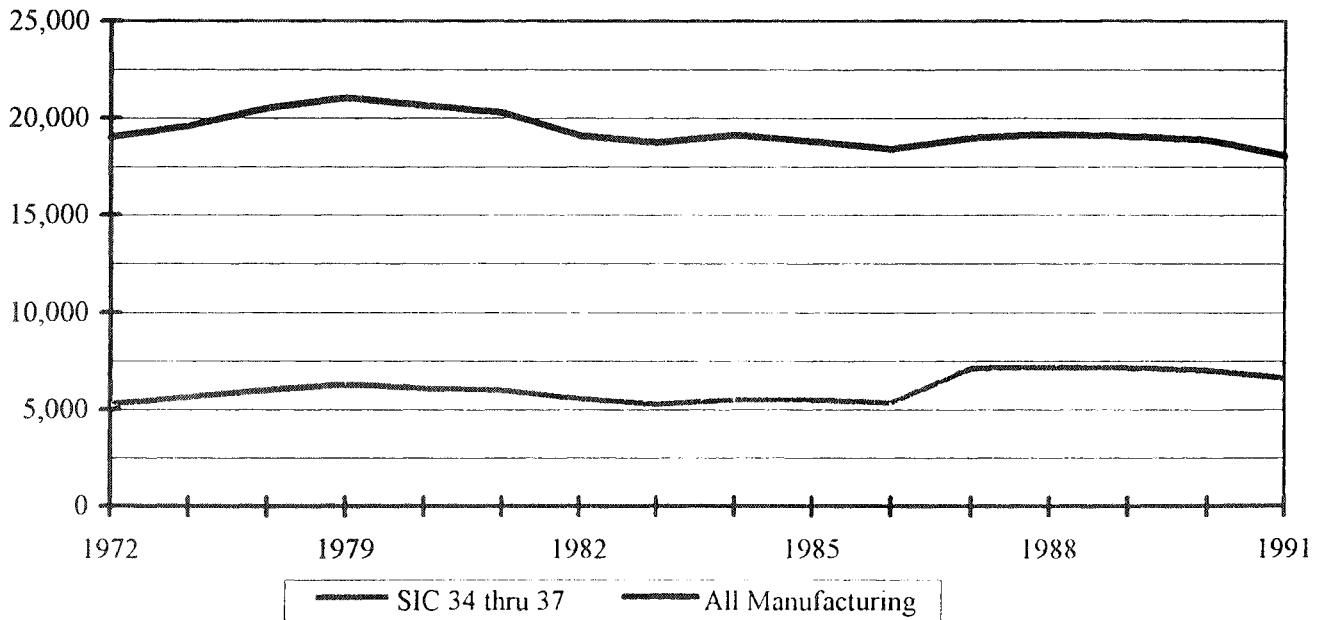

rates correspond with the sharp increase in total value of products shipped shown in Figure 1.1.<sup>4</sup> Whether this is purely coincidental is open for discussion. The matter is that automation levels have increased within industry, sales of electronic devices such as programmable logic controllers and computerized numerical controllers have been increasing while employment levels have been remaining relatively stable.

Also during this time, concerns for the environment began to be felt in industry. Congress was enacting several programs to reduce discharges into the air and water and generally improve the quality of our environment. This placed a further crimp on the manufacturing processes within the U.S. as many foreign competitors did not have to contend with these increasingly rigid environmental concerns. Other factors which manufacturers were compelled to address include enactment of the Clean Air Act in 1967 and the Clean Air Act Amendment of 1990, The Clean Water Act, The Water Quality Act of 1987 and the Resource Conservation Recovery Act. All of these factors influenced manufacturers to evaluate their manufacturing processes, identify where the costs to manufacture were incurred and to improve the total cost to manufacture their product while at the same time reducing or eliminating discharges into the surrounding environment.

Excluding materials and labor, energy purchases account for approximately 7% of the remaining cost of manufacturing, nationwide. Energy prices had been consistently rising until the early 1980's when deregulation of the oil and gas industry was enacted, causing prices to fall. However, around 1988 prices once again began to rise.<sup>5</sup> Figure 1.5, which plots the change in manufacturing energy intensity since the energy crises, shows the pattern one would expect given the trend in energy prices. As energy prices rose, energy intensity fell; as prices stabilized, so did energy intensity. It is interesting to note that increases in energy efficiency (or its equivalent, decreases in energy intensity) have been due to changes in fossil fuel use, not electricity use. As Figure 1.6 shows, electricity intensity is now at roughly the same level as existed prior to the 1973 oil embargo. In 1991, the manufacturing industry spent over \$55 Billion in energy purchases.<sup>6</sup> With the deregulation of the gas and oil industry came the advent of retail wheeling of natural gas by the end user. Once the exclusive realm of the utility companies, retail wheeling of natural gas has provided the manufacturing industry with the ability to reduce the total cost of providing natural gas. Since the enactment of The Energy Policy Act of 1992, a similar move is underway in the electric supply and transmission arena.

Prior to the 1980's, energy management was viewed as the ability to control the building environment, turning the lights on or off and controlling heating and ventilation requirements. During the oil crises of the 1970's energy conservation became the major role of the energy manager. The energy manager did what he or she could to get people to turn off lights in unoccupied areas. This energy manager also modified what controls were available to reduce heating temperatures and set some form of time schedule. The controls available were very limited in capabilities. Implementation of time schedules often involved connecting crude time clocks in parallel with manual controls. Lighting controls generally consisted of lighting contactors controlled by a series of low voltage switches and relays. Heating, ventilation and air conditioning (HVAC) controls were pneumatic in nature and were manufactured by a very select group. Companies such as Honeywell, Johnson Controls, Powers and Robertshaw dominated the field of environmental controls. Control and operation of these systems was a very cumbersome process. Operators and engineers were required to have very specialized knowledge of the operation of the controls as well as the equipment being controlled. The advent of the microprocessor and the development of electronic controls saw this knowledge change from a very mechanized domain to a more computer oriented base. Where manual operation was predominant, there are now computerized algorithms to control temperatures, lights and ventilation based upon use and occupancy of a building. What once consisted of simply paying utility bills has now become monitoring and reporting of utility usage by manufacturing process groups and automatic trending of utility usage over extended periods of time. Today's energy manager has grown from being a bill payer and HVAC operator to a person who supplies the plant with energy at the most cost effective and reliable manner possible, ensures the energy is used in the most economical manner possible, and reports current and forecast usage

---

<sup>4</sup> Ibid. 1991 ASM

<sup>5</sup> Guide to the Energy Policy Act of 1992, Williams and Good. The Fairmont Press, 1994

<sup>6</sup> Ibid., 1991 Annual Survey of Manufacturers

**FIGURE 1.5**  
**ENERGY AND THE ECONOMY**  
**(1949-1993)**

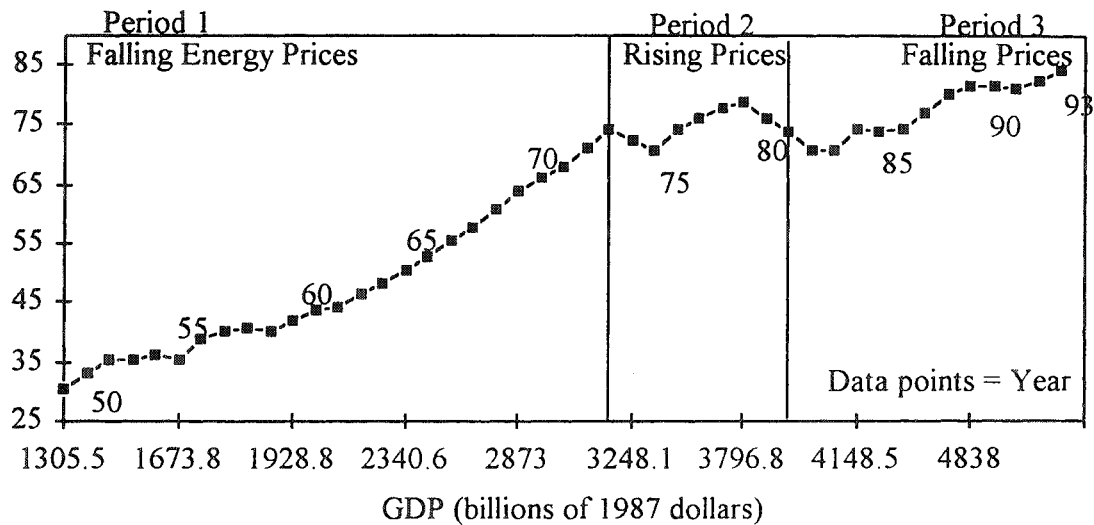

Source: Annual Energy Review (AER), 1993, Tables 2.2 and 8.1. 1993 data preliminary.

Notes:

1. Clearly, the old rule of thumb of a constant relationship between GNP and total energy use no longer holds: OPEC et al. broke the link.
2. During Period 1, energy costs fell, while the productive efficiency of the economy continued to grow without any change in the GDP/BTU ratio.
3. During Period 2, rising energy costs reduced energy use by substituting labor and capital for energy. This reduced labor and capital productivity. Hence, the economy continued to grow, but at a much reduced rate. The GDP/BTU ratio rose.
4. This increase was the result of:
  - an increase in industrial GDP/BTU (50%)
  - an increase in household GDP/BTU (33%)
  - a change in industry mix of products (17%)
5. During Period 3, we appear to return to Period 1 or 2.

Figure 1.6  
INDUSTRIAL ELECTRICITY (IE) AND FOSSIL-FUEL (FF)  
INTENSITY INDICES, 1949-1992

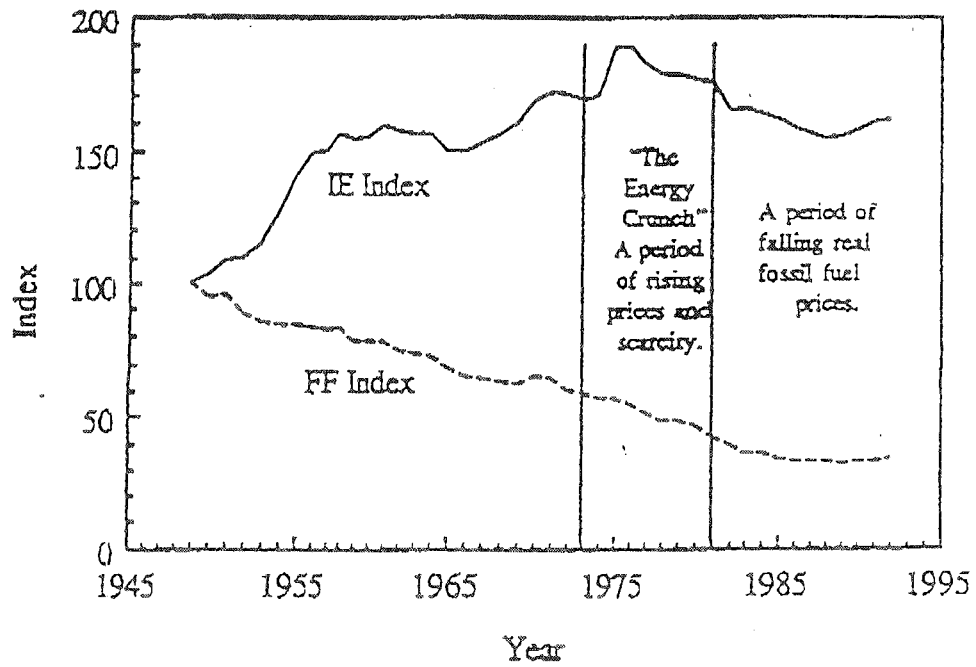

1992 value is average of first 11 months. Energy use/industrial output index: 1949 = 100.

Source: Schmidt, Sparrow, Vanston and Zarnikau, *Neoelectrification of Industry in the Information Age*, Exhibit 2.4, 1994.

to the plant manager so that he or she can have up-to-date budget data on current and projected manufacturing costs.

Many large corporations have complete staffs dedicated to energy management and controlling energy costs. Smaller companies frequently do not have the people available to support continuous process improvements and comprehensive energy management. These companies need to rely on outside sources for energy and efficiency improvements. These outside sources include U.S. Department of Energy's Energy Analysis and Diagnostics Centers (EADC's), various non-profit organizations, and an ever increasing number of consultants. There are a number of third party organizations which can help in the analysis, design, construction and funding of energy efficiency improvements.

## **Part 2 - Current Market Conditions**

Today there are nearly 350,000 industrial manufacturers in the United States. These manufacturers shipped a combined product value of more than \$2.8 Trillion in manufactured goods while spending in excess of \$55 Billion in purchased energy.<sup>7</sup> Of these manufactures, those which fall in SIC's 34 through 37 shipped goods with a combined product value in excess of \$960 Billion or approximately 1/3 of the total U.S. industrial manufacturers while spending only \$10 Billion in purchased energy or less than 1/5 of the total.

In terms of electricity, industrial manufacturers in all SIC codes purchased 756,061 million kilowatt-hours (kWh) of electricity of which manufacturers in SIC's 34 through 37 purchased 140,203 million kWh or slightly less than 19% of the total.

All of these numbers can very easily confuse the primary questions which are:

“Is there a real need to improve energy efficiency within industry?” and

“Why should manufacturers be involved in energy management?”.

Let's take a look at the first issue. Do we need to be concerned about energy efficiency?

As of 1993 there was a capacity to generate over 699,000 megawatts of electricity in the United States<sup>8</sup>. The maximum peak usage was 575,800 megawatts or slightly more than 82% of the total generating capability. Manufacturing industries, SIC's 20 through 39, consumed over 24% of this total energy. According to the Department of Labor, Bureau of Labor Statistics, U.S. industry has been experiencing an average annual labor growth of approximately 2% per year over the past 30 years. This would imply that industrial manufacturing within the U.S. is constantly growing creating an increasing demand in energy. With a slightly more than 18% difference between generation capability and peak usage, it would appear there is sufficient generating capability to cover anticipated growth for the next ten years. However, it should be noted that, at any given moment, a significant number of generating facilities are not operating for reasons of maintenance, major repairs, or the facility is used only for generating “peaking power”. Thus the difference between use and generating capability is much less than the numbers would indicate. It should be noted that utilities try to avoid using peaking power unless necessary as the increased cost of generation is frequently more than the average increase in revenue sales. Because of this, utilities frequently do not recover all of the operating costs when using peaking power. Another factor to consider is the continued use of nuclear power plants which generated over 21% of the power consumed. With rising maintenance costs and increasing concerns for safety, nuclear plants are the targets for closure by several groups, including utility shareholders and environmentalists. The Electric Power Research Institute (EPRI) projects an increase of 3,460 megawatts of generating capability by the year 2003. This reinforces the observation that utilities are concerned about the costs of generating capability and the availability of economically viable generating sources. By taking a closer look at the generating capability of the nation and the source of that generation, one could easily reach the conclusion that we should be concerned about the overall capacity within this country. Availability of energy and the reliability of the energy source are two very significant factors for concern from the industrial manufacturer's viewpoint as energy is directly proportional to manufacturing capability and therefore profits.

---

<sup>7</sup> Ibid., 1991 Annual Survey of Manufacturers

<sup>8</sup> 1993 Electric Power Annual Report, DOE/EIA 0348(93)

There are several methods for increasing the capacity within a utility system. These include new generation, purchasing power from areas with surplus capacity, reducing losses and conservation. New generation is a very restricted alternative at present. There are no new hydroelectric dams being built nor are nuclear power plants being built. Natural gas fueled generating plants are being built in limited numbers in certain areas where the supply and transportation of natural gas are at relatively low cost. Coal and coke fueled power plants are having their own problems complying with environmental regulations to such an extent that, in general, new plants are not being built. Utilities are reducing their losses by replacing existing generators, turbines, and transformers with more efficient types. Transmission losses are being reduced by adding capacitors and reactors at existing substations and by increasing the conductor size and type. Utilities are pursuing conservation through demand side management as one of the most viable and readily available sources of energy. There were 23 demand side management (DSM) programs in place prior to 1980. Since then, the number of programs has increased to over 2300 with more than 660 utilities offering DSM programs of one or more types. Of these programs, approximately 30% apply to industrial manufacturing. In a recent study (Jordan and Nadel 1993), the cost of DSM to a utility was stated as ranging from \$0.003 to \$0.045 per kWh saved. The same study indicated that new power plants range in cost from \$0.050 to over \$0.10 per kWh indicating that DSM would appear to be the more cost effective alternative.

On the industrial side, energy costs average less than 5% of the total costs to manufacture goods. This would indicate that energy plays a very small role in manufacturing costs. However, when considered in conjunction with new environmental constraints, energy efficiency improvements can have a very significant effect. For example, many medium to large industrials have a central steam plant using either natural gas, fuel oil, diesel fuel, or coal as a primary fuel source for large steam boilers. This steam is then piped around the plant for use in a variety of processes. The Environmental Protection Agency regulates the amount of emissions allowed into the atmosphere by these boilers. The amount of steam produced by the boilers determines the amount of pollutants released into the air. By replacing faulty steam traps and repairing leaks, not only is the amount of fuel burned in the boilers reduced, but the emissions from those boilers are reduced. When the boilers are operating on alternative fuels such as Bunker C, coal, or diesel fuel, these emission reductions could be the difference between compliance or violation with emission regulations. Any violation can mean very large fines or in the extreme, plant closure.

In addition to having an environmental benefit, efficiency improvements can also reduce the total cost of manufacturing by improving the methods. For example, a process where parts are loaded into an oven in large loads can be changed by placing a small preheat chamber in front of the oven and loading parts on a continuous basis. Timing adjustments on a conveyor system carrying parts through the oven can regulate the amount of time each part spends in the oven. In one instance, using this method, productivity was increased twofold while compliance to manufacturing specifications improved from 5% tolerance to 1%. The number of rejected parts decreased to virtually zero.

### **Part 3 - Answers**

Returning to the two questions presented earlier, answers can now be formulated. First, is there a real need to improve energy efficiency within industry? From the utility standpoint, the answer is yes. With problems associated with construction of new generating facilities, conservation and energy efficiency programs are the most likely sources of new capacity. From the industrial standpoint, manufacturing costs are rising and competition is getting fiercer. Improving energy efficiency has several benefits including reducing manufacturing costs and reducing environmental pollution. All of which may give a company the necessary edge over its competitors. A major problem facing both the utilities and industry is one of capacity, not cost. As utilities run out of capacity to satisfy the demand, certain customer classes are curtailed. To the industrial customer, being curtailed equates to lost production time.

The second question was "Why should manufacturers be involved in energy management?" Part of this question has been answered; to reduce total manufacturing costs and to help meet environmental requirements. The remaining portion of the answer is not so readily apparent. In relation to the total United States, the

manufacturing industries consume approximately 24% of the total energy consumed. While this may not seem large, it is the industrials who are frequently the targets for utility curtailment or demand limiting programs. If we, the industrial manufacturers, do not manage our energy usage, the utilities might manage it for us in attempts to keep load requirements within generating capabilities. In the Pacific Northwest Puget Sound Power and Light and Washington Natural Gas have both identified their industrial customers as the most likely to be curtailed first, followed by commercial, non-critical institutions, then residential. A common justification is that when it comes to curtailing energy in the middle of winter, who should be curtailed, the little old lady nice and warm in her house, or the large industrial? The answer is obvious: the large industrial.

The worst that could happen to industry is that government mandates energy efficiency levels and attempts to limit the amount of energy used by industrial manufacturers. If this possibility seems absurd, remember that similar thoughts existed in regards to pollution and environmental issues. Now there are myriads of regulations impacting how industry handles it's waste. Virtually every president since Franklin Roosevelt has tried to make the U.S. independent from foreign sources of energy. In more recent times, Presidents Carter, Reagan, Bush and Clinton have all proposed plans for reducing American dependence on foreign energy sources. In 1993 the United States imported over 2 Quadrillion BTU's of natural gas alone. As domestic sources of natural gas are consumed, the dependence upon foreign sources is expected to climb. Nuclear fuels are currently viewed as extremely hazardous to the environment. Coal and coke generating plants are forced to meet ever tightening environmental requirements. Hydroelectric generation has been reduced, especially in the Pacific Northwest, to assist in recovery of endangered fish species. All of these are indicators that power generation and energy supplies within the United States are limited and that we, as a Nation, are approaching those limits. In much the same way that we have seen an increase in environmental regulations, we may see government take a similar stand on energy.

Another possibility are utility mandates on energy usage and the required implementation of energy conservation. This is a very likely scenario. One of the groups already experiencing utility intervention are the large aluminum smelters in the Pacific Northwest. These customers, referred to as Direct Service Industrials, or DSI's, are offered incentives in the form of significantly reduced utility rates in exchange for being curtailed in the event of problems on the power grid or reduced power generating capabilities. These DSI's receive their power direct from the Bonneville Power Administration (BPA). BPA has been experiencing reduced generating capacity within the Pacific Northwest for several reasons, including drought conditions in the Columbia River and Snake River watersheds, and increased flows around the generating turbines to satisfy stream flow requirements for endangered fish species. As a result, the DSI's have had their loads curtailed by 25% for most of 1994.

In summary, industrials around the nation need to get more involved in energy conservation and energy efficiency improvements for reasons other than cost. Although energy costs are a very small portion of the cost of manufacturing a product, loss of that energy means lost production and lost income. This country is approaching an energy barrier beyond which there is no more capacity to be had. Curtailment of industrial energy usage is already a fact of life in some areas of the country and it is only a matter of time before it becomes widespread. Another reason industrials need to be proactive in energy conservation and energy improvements is political in nature. Governments, utility commissions and utilities themselves will set both rates and policy based on impact to the residential community. By presenting a "Good Neighbor" image, industry can help reduce negative politics directed at industry by the other sectors.

In Chapter 2, we will address the energy manager, the desired qualifications, and some of the basic first steps an energy manager should take. In Chapter 3, we will take a closer look at several programs developed by government agencies to motivate industrial manufacturers to reduce energy consumption and/or improve energy efficiency in manufacturing. We will also look at demand side management programs sponsored by utilities. Chapter 4 presents a method of projecting the energy savings by changing the end use process. Chapter 5 provides the tie-in with the previous chapters showing how industry, utilities and government can work together to reach a common goal. No single entity can be really effective without the cooperation and participation of the other two. Examples of how the three groups can work together effectively will be presented in Chapter 5.

## CHAPTER 2 - THE PLANT ENERGY MANAGER

### Part 1 - Introduction

Each plant or facility should have an individual who is responsible for the utility usage at a plant. This person should be responsible not only for paying the utility bills, but for insuring the utilities are being utilized in the most effective manner. This latter responsibility can take many forms ranging from making sure the plant is being charged at the best rate available to insuring the equipment and processes are the most cost effective and energy efficient available. In addition, this individual should continuously evaluate new and existing programs and products for applicability, cost effectiveness, degree of efficiency improvement as well as appeal to senior management. First is applicability, does this program or product apply to the facility, the methods of manufacture in use or the type of buildings occupied? Next is cost effectiveness, does this program or product provide benefits which will pay for itself within a few years? Then there is degree of efficiency, by implementing this program or installing this product will the efficiency of manufacturing or operating the facility improve to any significant degree? And finally, does the project or product appeal to senior management; does it's implementation or use take the facility in a direction the senior managers would like to see the facility develop into? All of these are questions that should be answerable by the energy manager. This chapter will look at the qualifications of an energy manager, some of the functions an energy manager should perform and some basic steps an energy manager should pursue from the first day on the job to a continuing role and some of the tools available to the energy manager. This chapter should provide guidance to the energy manager in the search for answers to the above questions.

Throughout this chapter, reference is made to the plant energy manager. This is a name provided for ease of discussion. The function of the plant energy manager may actually be performed by a group of individuals operating under the guidance of a manager with the entire group having a common goal or objective, to optimize energy usage at the manufacturing plant. The qualifications presented below, should be represented throughout the group. The apparent best mix is where most of the members of the group, especially the group manager, share all of the qualifications listed.

### Part 2 - Qualifications

The best way to describe the basic characteristics of an effective energy manager are that they are varied at best. There is no single qualification that makes a good energy manager, but there are some which are common to many effective energy managers throughout industry. In this paper we attempt to identify those qualities which are common to most effective energy managers. This list is by no means complete, nor does this list set minimum requirements. Rather, it provides recommendations based upon discussions with energy managers and energy management related individuals in both the industrial and consulting fields.

At the top of the list, this individual should be a self starter motivated primarily by a desire to get the job done in the most effective manner possible. An effective energy manager is constantly pursuing ways to improve, both in themselves and in performance of the plant. This means that goals are set, plans are developed to reach those goals, metrics are determined to evaluate performance, schedules and milestones are set for accomplishing the goals and regular review periods are set to determine progress towards meeting the goals. This individual is constantly reviewing trade publications for new ideas or new ways of looking at their processes.

The next highest qualification is to be a good communicator. The energy manager accomplishes very little alone. The most effective achievements are accomplished by motivating others to help accomplish a common goal. A good example is in energy conservation. The energy manager can make daily rounds of the plant, turning off lights and machinery in unoccupied areas. This is very time consuming and permits very little time for the energy manager to pursue other activities at energy management or cost reduction. At medium or large facilities, this is an impossible task. On the other hand, if he or she is a good communicator, the energy manager can motivate the shop personnel to turn off their machines or systems when they are done for the day and to turn off the lights at the



end of the workday. This permits time for the energy manager to review plant performance, update forecasts and research methods of improving plant efficiency.

The energy manager should also be a good salesman. It takes considerable skill to sell a program which is going to reduce short term net profits in exchange for long term gains when the owner or stockholders are expecting an increase in both profits and long term gains. In both large and small companies, it is very difficult to sell a program which may have a 5 to 10 year return on investment when the improvement has little or nothing to do with manufacturing products. For example, a manager is more likely to spend \$500,000 on a machine which manufactures more parts than on improving the lighting system in the same area. Even though the lighting system may have a better rate of return on investment as well as a positive impact on the people working in the area. Salesmanship will be discussed later in this chapter.

Next the individual should be computer literate. This means the individual is very comfortable working with computers, and is fluent in spreadsheet, database, word processing and presentation type software programs. Spreadsheets and databases are good tools for collecting data, keeping track of both consumption and opportunities, and for evaluating the effectiveness of a program. Word processing and presentation type programs are effective tools to assist the energy manager at selling ideas, reporting status, and communicating with others. An additional benefit can be gained if the energy manager can program machine or system type control computers ranging from programmable logic controllers to building energy management systems, especially in the small to medium sized plants where manpower is a premium. This permits the energy manager to implement energy reduction routines into system controls without having to rely on others, including consultants. In many instances this can result in significant cost savings in the implementation of energy reduction plans, improving the payback rate.

Finally, the individual should be either a mechanical or electrical engineer with a strong background in control systems. It should be noted that in interviewing a number of energy managers, a significant number were non-engineering types. However, in virtually all cases, the energy manager was extremely well qualified in most other aspects. By having an engineering background, the energy manager can evaluate processes and systems, identify potential improvements and determine which improvements would be cost effective to pursue without calling upon external resources.

### **Part 3 - Functions (What does the Energy Manager really do?)**

The ideal plant energy manager has a wide range of responsibilities. In smaller firms, some of these responsibilities may be taken on by accountants, plant engineers, plant operators and clerks. In larger firms, these responsibilities may be shared by a group of people. The following is a listing of some of the more significant responsibilities of the Plant Energy Manager. Each of these items will be discussed in greater detail.

- Pay the utility bills, including monitoring and tracking.
- Report to management providing visibility of energy usage
- Perform energy audits on a regular basis.
- Review current manufacturing processes for opportunities
- Obtain funding for implementing efficiency improvements
- Evaluate plans and designs for opportunities and provide recommendations
- Communicate with factory personnel on energy matters

#### **Pays the bills and collects data**

One of the basic functions of the energy manager should be to either pay the bills or approve the expenditure. As a minimum, the energy manager should monitor and track actual utility usage and costs. By tracking usage and costs, improvements can be evaluated for effectiveness, realistic forecasts can be developed for subsequent years, and new opportunities can be identified. One of the first things a new energy manager should do is to review the current utility bills for accuracy, correct billing schedule, and correct meter assignments. As discussed later in this chapter, many things can have an effect on the utility bill from inappropriate rate schedule to estimates of usage

versus actual meter readings. The energy manager should also develop baseline data so that future programs and efforts can be evaluated. By collecting the data and analyzing the information, trends can be identified which may lead to the identification of opportunities that may have been otherwise overlooked.

#### **Report to management providing visibility of energy usage**

The data that is collected by the energy manager should be compiled into periodic reports to management. These reports should provide current status of projects underway, effectiveness of programs to date, current and forecast utility costs and usage, changes in utility industry and other issues that may have an impact on energy costs. This provides management with the feedback necessary to evaluate the programs from a business standpoint.

#### **Communicate with factory personnel**

Effective communications can be one of the most effective a tool at reducing energy costs. The Allen-Bradley Company claims that 10% to 15% reductions in energy cost can be obtained simply by communicating to the building occupants and management what the actual usage within a building and what the costs are to operate the building. In areas where automatic controls do not exist, communicating with shop personnel the need to manually turn off the lights when the area is unoccupied and reporting back on the effectiveness of doing so, can have a significant impact. For example, At Boeing's Everett aircraft assembly plant, one building was selected that could be isolated from the rest of the plant in terms of utility usage. A comprehensive communications program was implemented to determine the impact on utility usage. The program explained the need for reducing energy costs and presented options at how those costs could be reduced. These options included turning off lights and machinery at the end of the work day and identifying individuals assigned to ensure all equipment was off. The end result was a 12% reduction in utility usage with no sacrifices by the shop personnel and a very minimal initial cost to implement the program.

#### **Perform energy audits**

The energy manager is the best person for performing energy audits or in getting the audits performed. Regular audits of the manufacturing and support areas provide feedback on current programs, identify opportunities for improvement, and update priority assignments. Recommendations on the frequency of audits vary from quarterly when providing current status of projects to once every three to five years when searching for opportunities. The EPA programs discussed in Chapter 3 recommend audits be performed every five years for primary systems. It is suggested that a regular routine be established to perform energy audits of the facilities for the purpose of identifying possibilities. It is also recommended that a second, more frequent schedule be developed for evaluating the effectiveness of current and past programs, such as having the shops turn off the lights. This more frequent schedule will identify where programs are working and where they are not. Communications may be the only thing required to improve those areas falling behind.

#### **Review current processes**

As part of the longer term regular scheduled energy audits, the energy manager should review the current manufacturing processes for opportunities. Developments in motor drives, electrotechnology, or other manufacturing technologies may change the way a company manufactures products. For example, recent changes in painting technology have resulted in development of a new paint application process that is less energy intensive and produces fewer hazardous waste byproducts.

#### **Develop both short term and long term plans for improving processes and sells to management**

Without a plan, the energy manager's job takes on the appearance of mundane routine work with no direction or goal. By establishing goals and developing plans to reach those goals, the energy manager's job gains direction and purpose. By developing these plans, senior management can assign funds or can schedule the assignment of funds to programs which are effective. In instances where money is scarce, planning provides a means of identifying the sequential expenditure of lesser funds to reach the same goal. It also provides a means of communicating to management the need for energy improvements and provides an evaluation of the cost effectiveness of proposed programs.

### Evaluate plans and designs for opportunities

The energy manager should be in constant touch with design engineers and facilities engineers. There should be a constant communications between the groups to keep the energy manager aware of the physical changes occurring in the plant and allowing energy efficient improvements to be incorporated into the design. It is often the energy manager who provides system improvement recommendations. The design engineers often look for easy economical solutions to get the job done in the time frame allotted. Rarely does this method correspond with the most energy efficient and cost effective solution. This communications between groups has the added benefit of providing the energy manager with data regarding changes in plant load that can be included in utility consumption forecasts.

### **Part 4 - Opportunities**

There are several opportunities for the wary energy manager to take advantage of. To uncover these opportunities, the energy manager needs to know not only what to look for but also where to look. Simply walking around the plant visually inspecting systems may identify a number of possibilities but will not uncover all of the opportunities available. This section identifies some of the more typical systems the plant energy manager will be involved with and offers a few suggestions on improving system performance. There are three general categories of opportunities available and each will have different effects on the overall efficiency baseline. These categories are maintenance opportunities, engineering and design opportunities, and utility rates opportunities. With everything held constant (utility rates, production rates, headcount, etc), and assuming everything works properly, a baseline efficiency can be developed. As systems age, maintenance opportunities will present themselves. Energy audits and design reviews will uncover design opportunities which incrementally lower the baseline. By changing the utility rates, the entire baseline is shifted downward. The following paragraphs discuss some of the opportunities available from each of the three categories.

### Lighting Systems

An opportunity that has been highlighted by the Green Lights program is in the lighting systems, including fixture types and control systems. One thing not emphasized by the Green Lights program is the effectiveness of appropriate time schedules and the provisions for manual overrides. After reviewing which hours a shop occupies a given area, the controls can be installed or modified to accommodate the shop schedule. For example, a building with 100,000 square feet of floor space may use 180 kW of electricity each hour for lighting. If the lights can be turned off for 6 hours during the night when no one is working in the area, 1080 kWh per day can be saved or more than \$75 per day at \$0.07 per kWh. This is a basic premise of Green Lights. However, if manual overrides are provided, additional savings can be realized if the shops can turn off lights in smaller areas earlier than would be provided by the automatic controls. Control systems such as General Electric's TLC System and Powerline's WATCHKEEPER System among a variety of others, can be programmed to take advantage of differing time schedules. In addition to the automatic sequences, most lighting control systems can be programmed to accept manual overrides from low-voltage control switches installed on the factory floor. Shops which utilize overtime instead of an established extra workshift appreciate having control at the floor level and are more likely to participate in conservation programs. Books that can be of assistance in designing effective lighting systems include the IES Lighting Handbook, Volumes I & II, which provides a fairly comprehensive discussion on lighting design. Philips Lighting's Lighting Handbook and Sylvania's HID Clinic are two manuals developed by lighting manufacturers that provide easy to understand discussions on lighting design.

One note of caution is in inspection areas. Metal fabricators have a variety of inspection areas measuring properties ranging from hole or part dimensions to reflectance of light and color of light reflected. Lighting quality is at least as important as lighting levels. Shadowing or color shifting can cause problems which may result in failure to identify poor quality parts. This can lead to total replacement of the lighting system with a less efficient method, if the inspection requirements are not taken into consideration at an early stage.

## HVAC Systems

Virtually all manufacturers of current HVAC control systems provide the capability for multiple time schedules. It is not uncommon for industrial buildings to have more units than are required to supply adequate ventilation. The energy manager should determine existing program schedules, ventilation provisions, and setpoint levels. The next step would be to determine the building needs and ventilation requirements and adjust the time schedules and setpoints accordingly. The Energy Star Buildings program calls this giving the building a tune up. This tune up has several benefits. First, it identifies the needs of the current occupants. Next, it will save energy by optimizing the fresh air requirements for the building allowing units to be turned off and dampers to be closed during off-hours or when not needed. This should reduce the heating and/or cooling requirements by utilizing return air to the most optimum level. A long term program should be developed to evaluate HVAC units for applicability of variable speed drives. Most units supplied prior to 1986 will have single speed fans and will utilize dampers and control valves to maintain air flow and temperature requirements. The 1991 ASHRAE Handbook on HVAC Applications<sup>9</sup> provides a guide to energy management systems as well as a fairly comprehensive economic analysis section. Two very good books on energy auditing and upgrade techniques are SMACNA's RETROFIT of Building Energy Systems and Processes and The Boiler Efficiency Institutes handbook HVAC Efficiency Improvement. Both books provide a fairly comprehensive yet easy to understand discussion on improving the efficiency of plant HVAC systems. Other books include HVAC Systems Evaluation by Harold R. Colen and HVAC Design Criteria, Options, Selections by William H. Rowe.

## Steam systems

The plant steam system is very closely related to HVAC, with over 60% of the steam load being delivered to HVAC units. Heating accounts for 29% of the total energy used by manufacturers in SIC's 34-37. On the national average of all industrial manufacturers (SIC 20-39) natural gas and electricity account for over 52% of the total energy used for heating.<sup>10</sup> However, steam is also used in the manufacturing process to heat process tanks, low temperature ovens, press platens, and paint booths, among other things. One of the most common problems associated with the steam system is in steam trap leaks and failures. If neglected for several years, these leaks can be responsible for a significant portion of the heating load. Walter Deacon, in a paper titled "Successful Steam System Operation Strategies", 1993, performed a study of 16 different steam systems and found energy losses accounting for as much as 30% of the total heating load. It is not uncommon for steam traps to be neglected as the steam lines are frequently routed in tunnels, trenches, in the overhead trusses, or other areas comparatively inaccessible. To overcome this, several manufacturers have developed infrared scanners that can inspect steam valves and steam traps at significant distances (upwards of 50 feet away). These scanners cost between \$1,500 and \$3,000 and require very little training to use properly. By performing regular surveys of the steam system, leaks can be identified and repairs made before the losses become severe.

Condensate return systems are a very closely related system where opportunities may exist. By returning steam condensate to the boiler system, reductions in water and water treatment chemicals can be realized. Energy can be saved by reducing the amount of energy required to turn 160-degree condensate water to steam versus 40-degree make-up water.

## Cooling Water

Plant cooling water (as opposed to chilled water) is frequently used for machine tool cooling and as a heat sink for a chilled water system. This system utilizes pumps and valves for regulating flow and cooling towers and fans for regulating water temperature. Opportunities to reduce electrical usage exist by using variable speed drives on the pumps and fans instead of the regulating valves and recirculation loops. Opportunities exist to reduce water consumption by monitoring conductivity of the cooling water and regulating the number of blowdown cycles. Using alternative sources of cooling water can also help, as discussed in the attached case study. Refer to the books discussed under HVAC, above, for assistance.

---

<sup>9</sup> ASHRAE Handbook, 1991, HVAC Applications, I-P Edition

<sup>10</sup> Manufacturing Consumption of Energy, 1991, December 1994, Tables A4 & A36, DOE/EIA 0512(91)

### Compressed Air and Vacuum

Many manufacturers utilize compressed air or vacuum systems for a variety of reasons. Vacuum system usage ranges from simple housekeeping to holding parts on milling beds. Usage for compressed air range from powering hand held pneumatic tools to cushions for stationary dies in stamping presses. These systems frequently utilize large motors operating centrifugal, reciprocating, or screw type compressors or pumps to furnish the air or vacuum to the rest of the plant. Installing variable speed drives on the motors and modifying the control systems to sequence multiple units are opportunities that are available in most systems. Providing units of varying sizes and staging operation of the units can accommodate significant changes between on-hour and off-hour loads. Another concept is to segregate the system into segments which can be isolated from each other during periods of low usage. Air and vacuum systems appear to be more susceptible to leaks than any other plant system. In addition, many leaks are either undetectable or inaccessible. Price and Ross<sup>11</sup> identified leaks as accounting for losses ranging from 10% to 25% of system total energy usage. Regular surveys using ultrasonic sensing equipment can identify leaks at many different types of connections and in locations where it may be difficult or impossible to identify by ear. The amount of leaks within any particular system can be estimated by the energy required to maintain system pressure when all manufacturing and facility related equipment is turned off.

### The Manufacturing Process

Each plant differs from every other plant in innumerable ways, but within the metals fabrication industry there are some very high-level processes that are common. In very general terms a product will go through the following steps on the way to becoming a finished product. Those steps are:

1. Raw Materials delivery. This is the delivery of the raw product from the supplier. It can include flat sheets, preformed bars, tubes or rolls.
2. Forging and Casting. This step may be included in the raw materials section in that the forging and casting may be performed by the raw material supplier.
3. Cutting and Shaping. This covers the cutting, shaping, forming, milling, machining and grinding of the materials into the basic shapes. This stage may also contain hand work and preliminary finishing.
4. Treating and Coating. This step includes heat treating, stress relief, curing, aging, shot peening, sand blasting, anodizing, and plating, among others. This is generally one of the last steps the materials are subjected to prior to finishing.
5. Painting and Finishing. This is where the finished product is developed. It includes priming, painting, polishing, installing protective finishes, and assembling the final product, if applicable.
6. Packaging and Shipping. Here the final product is packaged in containers, boxes, shrink-wrapped or placed on flatbeds and delivered to another site.

In addition to the above steps, inspection and rework may be dispersed throughout the entire manufacturing process. Also note that assembly has been included in the painting and finishing step. This is because not all manufacturing plants have assembly as the final product consists of individual parts. In other cases, the fabrication sections are at separate facilities from the assembly sections.

The energy manager needs to be aware of the manufacturing process, especially in evaluating products for applicability and in identifying opportunities. For example, the cutting and shaping section generally results in metal chips as a byproduct. Getting the chips away from the cutting heads may be accomplished using a vacuum system with a pickup adjacent to the cutting heads. This vacuum system can use large horsepower motors as the power source and baghouses with filters as the destination. It is not uncommon to find the chip collection system operating when no chips are being made since the chip collection system was most likely not manufactured by the machine tool vendor but was added on-site by an equipment engineer or OEM. By interlocking the chip collection system with the mill controls, the chip collection system can be started and stopped in synchronization with the mill. Many large milling machines will also have hydraulic power packs for positioning spindles or moving

---

<sup>11</sup> Reducing Industrial Electricity Costs - an Automotive Case Study, Price and Ross. The Electricity Journal

materials or beds. These hydraulic power packs usually have a pressure regulated control circuit, i.e., the pump motor runs when the pressure is low and is off when the pressure is high. With hydraulic systems being notorious for leaking, it is common to find a hydraulic power pack cycling on and off when the mill is not operating. Interlocking the hydraulic power pack controls with the mill controls can reduce that problem.

An example of changing processes was highlighted by Hopkins and Jones in their book Getting In Gear. In the section on Fabricated Metal Products, the Coors Brewing Company was highlighted. By changing from a thermal curing system for the cans to an electric ultraviolet system, significant energy savings were made (the UV system uses only 8% of the energy consumed by the conventional method), overheating damage was virtually eliminated and production was greatly increased.

## **Part 5 - Utility Billings**

A number of opportunities exist to lower a plant's utility billings by simply analyzing the current utility billing process. The plant energy manager should be aware of these opportunities and should take advantage of any which may be available and economically viable. The following section describes some of the opportunities available. There are 5 utilities that the energy manager needs to address; electricity, heating fuels, water, sewer, and solid waste. Consumption of each of these utilities is measured differently, regulated by different agencies, and usually supplied or handled by different companies.

### **Special Contracts**

Utilities use a number of factors including cost of service to develop rate schedules. In some cases, an industrial customer may be able to negotiate a special contract with the serving utility to obtain energy at lower costs. The potential savings range from 5% to 40% depending on the utility, customer size, load factor, and others. Special contracts vary significantly and reflect the importance of a customer to the serving utility. With the deregulation of gas and electricity, special contracts may become the rule instead of the exception. Currently, many state regulating agencies are reluctant to approve special contracts fearing adverse impact on the residential sectors. In tomorrow's environment, utilities will be competing against each other to supply energy to the industrial sector, forcing the regulating agencies to also consider the future of the utility company. Hopefully, this will result in lower energy costs to the industrial manufacturer.

Several cases have been presented in which the end user thought they had negotiated for power at a significantly reduced cost, but on further analysis (not always by the end user) it was discovered that certain aspects had not been accurately represented. For example, several of the direct service industrials (DSI's) served by the Bonneville Power Administration (BPA) were approached by a third party independent power producer (IPP) claiming the IPP can supply power to the DSI's at a cost lower than BPA. Upon analysis, BPA discovered that while the IPP can generate power at a lower cost, the transmission rates were not accurately represented. In fact BPA could provide power to the end user at a lower total cost than the IPP. This example highlights the fact that the plant energy manager needs to be aware of ALL of the costs associated with obtaining power as well as the "hidden" factors governing how those costs are generated.

### **Electricity**

Electricity accounts for the major portion of most industrial manufacturers utility costs. Ensuring these costs are kept to a minimum is a very difficult job for the energy manager. One of the first things an energy manager should verify is that the facility is being billed in the most optimum manner. When a utility company provides the initial connection to the facility, the rate schedule assigned is based on some very basic assumptions (for example available voltage level and estimated load). These assumptions may not necessarily be correct. Figure 3.1, below shows a one-line representation of an electrical service to a plant. Frequently, it is to the customer's advantage to own the transformer and related equipment thus permitting the customer to be on a higher voltage tariff. Most utilities have a minimum load requirement for connection to each level. For instance, connection at Point A in Figure 2.1 may require the customer have a minimum load of 5,000 kW and a load factor of not less than 40%.

Whereas, connection at Point B may require the customer have a minimum load of 500 kW with no concern for load factor. Load factor is defined as the ratio of the average load to the maximum or peak load.

The electrical bill contains some very interesting information that can lead to changing current rate schedule for a more advantageous rate schedule. Table 2.1, below, lists items common to the electric utility bill.

Table 2.1 - Typical Electrical Billing Components

Description	Definition
Rate Schedule	This is the tariff rate at which the facility is billed. May include voltage level and other info
Billing Period	Start and ending dates for the billing cycle.
Power Factor	Efficiency at which electricity is used. It is the ratio of real power to apparent power.
Usage	The amount of energy used during the billing period, generally in kWh, but may also include reactive power usage or kVARh.
Demand	The peak amount used, or peak amount billed, during the billing period.
Meter Information	Information applicable to the specific meter, including meter ID, meter multiplier, and starting and ending meter readings.
Customer Charge	Minimum monthly charge
Fuel Cost Adjustment	A charge that allows for cost of fuel changes to be passed on to the customer
Ratchet Charges	These are charges that can apply to both demand and usage.
Contract Demand	An agreed upon demand level that represents a contracted minimum level of usage
Taxes	Applicable state and local taxes
Equipment Rentals/Charges	A charge for renting transformers, switchgear and other physical pieces of equipment.
Miscellaneous Charges	May or may not be present based on location and utility. Can include such things as school taxes, PUC charges, etc.

The energy manager should obtain a copy of all applicable rate schedules, including general terms and conditions, from the serving utility. The next step would be to analyze the electric bills and determine if a more advantageous rate schedule applies. Changing rate schedules may involve nothing more than a letter to the serving utility with a justification for the change. Another consideration to review is reactive power charges. Utilities charge for reactive power by billing on the power factor, billing on peak demand, and/or by billing on actual reactive power usage, depending on the utility and on the rate schedule. By moving to a different rate schedule, the customer may avoid billings on actual reactive power usage.

### Power Factor

As discussed above, the electrical utility bill may have a component dependent on power factor. This component may be in the form of a demand charge or an actual reactive power charge. Typically, these charges can be reduced by the installation of capacitors or synchronous condensers at the utility delivery point. However, there are problems that the energy manager should be aware of. Industrial manufacturers are using more solid state devices as components in the manufacturing process, especially as rectifier circuits in motor drives, plating lines, and ovens or furnaces. In addition to being sources of power system harmonics, these rectifier circuits can interact with the power factor correction capacitors potentially resulting in damage to motor and/or transformer insulation and incorrect tripping of protective circuit breakers. A comprehensive power system analysis should be performed prior to the implementation of capacitors.

# FIGURE 2.1 TYPICAL ONE-LINE

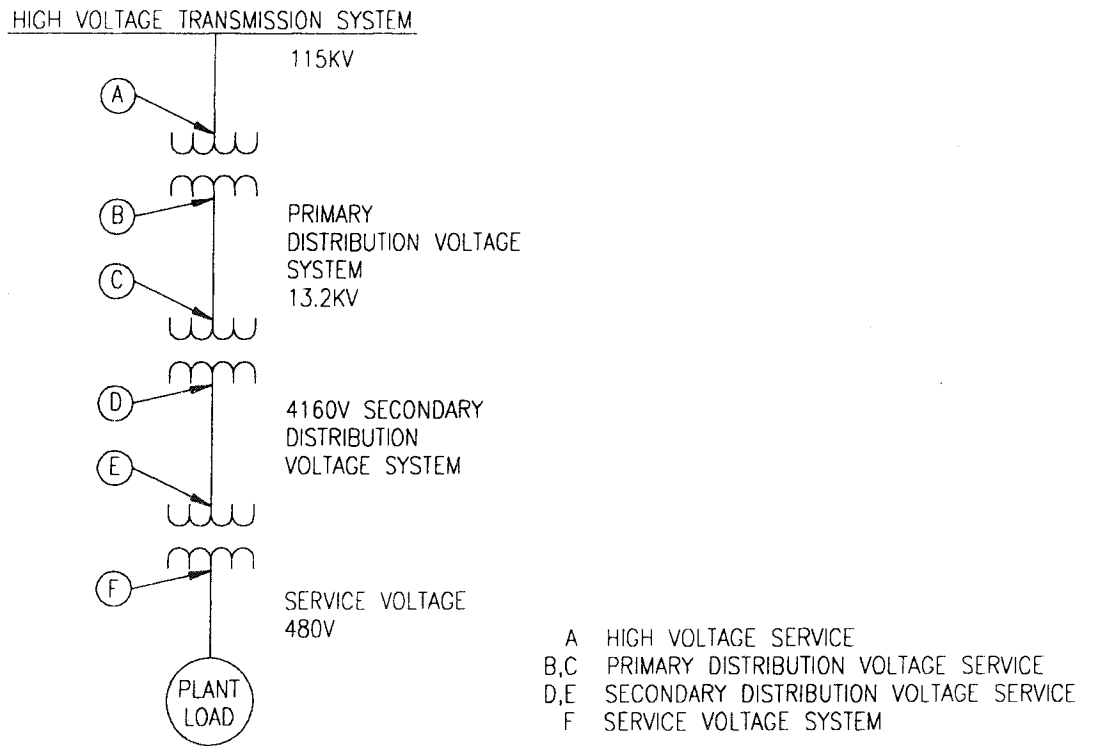

# FIGURE 2.2 NATURAL GAS ONE-LINE

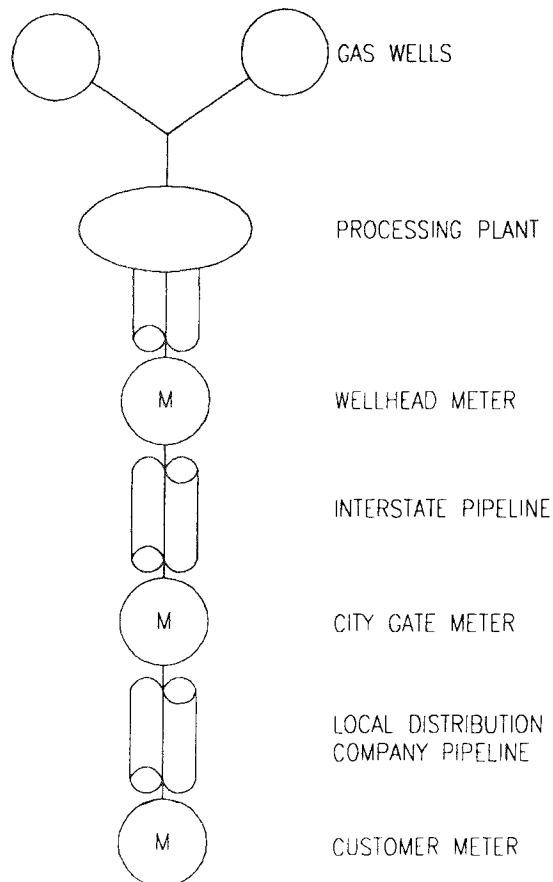



**Heating Fuels**

Heating fuels come in many forms depending on the area the facility is located within. These fuels include natural gas, diesel fuel, heavy liquid fuels, coal & coke, propane and liquefied petroleum gas (LPG). Delivery of the liquid fuels and solid fuels can be via either truck or train and are typically measured in physical units such as gallons or tons. Any applicable rates are based on actual volumes received and occasionally may require minimum delivery amounts. In rare instances, propane and LPG are delivered via piped systems from large storage areas by the serving utility. Natural gas, however, is virtually always piped and is measured in thermal units ( mmBTU's or Therms where one mmBTU = 10 Therms). Natural gas may have several different types of rates depending on the type of service required. Rate schedules vary depending on the amount of gas used, whether the gas utility provides full service or limited service, such as transportation only, and whether the gas is firm gas or interruptible gas. Figure 2.2 is a one-line representation of the natural gas transportation system. Table 2.2, below identifies the various charges that go into determining the total gas costs. The total cost of gas can usually be reduced if the industrial customer is willing to take on the responsibility and associated risks of purchasing and transporting gas without relying solely on the local distribution company (LDC). For example, The Boeing Company in the Puget Sound region reduced natural gas costs by over 10% by purchasing and transporting gas via the interstate pipeline, independent of the local LDC.

Table 2.2 - Natural Gas Billing Components

Type of Charge	Description
Wellhead Cost	This is the price of the gas at the wellhead meter.
Marketer's cost	Essentially this is the costs incurred by the marketer in obtaining the gas plus a small profit.
Interstate Pipeline Capacity	Payment for space to be allocated on the pipeline
Interstate Pipeline Transportation	A volumetric charge determined by the amount of gas transported
Miscellaneous Interstate Pipeline Charges	Includes gas storage fees, Gas Research Institute (GRI) fees, take-or-pay charges, minimum transportation charges, etc.
Local Distribution Company Transportation Charges	The cost of moving the gas from the city gate meter station to the burner tip
Taxes	Applicable state and local taxes

When the LDC is the sole supplier of natural gas, all other costs are hidden from the customer and may or may not be better than what the customer can obtain. There are some drawbacks to purchasing gas independent of the LDC. First, it requires that an individual order gas on a daily basis, monitor actual usage and minimize the difference between what is ordered and what is used. Both the interstate pipelines and the LDCs require that balancing occur as frequently as weekly with stiff penalties established for both over and under nominations. Electronic bulletin boards have been established for the daily ordering (called nominations) of natural gas and the shipping of that gas from the wellhead to the city gate. Second, contracts require frequent renewals, whether it is for spot gas, long term base loads or peaking loads. This can involve a significant effort on the part of the customer to ensure that all terms and conditions are acceptable. Finally, the LDC's may curtail gas usage for a number of reasons, including disruptions of service (such as the line breaks), excessively low temperatures causing increased demand by the residential sector and other higher priority customers, and insufficient capacity at times of high demand. Each LDC has established a curtailment priority list and it behooves the energy manager to research that listing prior to recommending a commitment to transport gas. One item of interest, it is usually the full service industrials who are curtailed first, followed by full service commercial accounts then transportation industrials. This could be the difference between having to burn more expensive alternate fuels during extremely cold weather or burning less expensive natural gas.

### Water and Sewer

Water and sewer are very small portions of the total utility costs incurred by an industrial manufacturer. However, significant cost savings can be realized by reviewing the billing method and improving any deficiencies. It is not uncommon for the sewer charge to be ten times the water costs and be based solely on the amount of water delivered to the facility. Water meters have a tendency to drift in accuracy and if left alone for several years can be as much as 25% in error. It is in the best interest of the industrial customer to ensure the meters are calibrated at least on an annual basis. Manufacturing facilities which have process tanklines frequently have to pretreat the discharge water to remove contaminants such as chromium and zinc. Because of the hazardous metals content, there is frequently a large surcharge attached to the sewer bill for metal content based on volume and periodic sampling for content.

There are several ways to reduce the sewer billings without impacting shop production. Where the water and sewer are both based on readings from a single meter or set of meters, install submetering on both sides of evaporative processes, such as cooling towers, settling tanks, process tanklines, rinse tanks, landscaping, etc. By determining the difference between the incoming and outgoing water flows, a deduct value can be obtained to calculate sewer discharge. After establishing a history of reliable readings, utility companies can be convinced to use the deducts from the water meters to determine truer sewer discharge. Another method is to install weir type metering stations complete with chart recorders, on the sewer discharge lines from the facility. Although this type of metering is not accurate, it is also not as susceptible to variation or plugging as are turbine types. Again, this may require convincing the local utility company that the metering is valid by presenting a history of readings.

Other problems that can be encountered include paving over the meters making them unreadable. In one instance, the serving utility could not find the meters, so the usage was estimated based on historical load. When shop usage was drastically reduced with no corresponding change in meter readings, the customer conducted an investigation to find the flaws. The investigation resulted in over \$400,000 being reimbursed from the utility as well as the installation of handholes in the street pavement.

For plants with process waste treatment facilities, an opportunity exists to reduce hazardous waste volumes. The installation of a sludge drying process at a central collection site can reduce large, liquid or semi-liquid volumes to much smaller cake, brick or dust volumes. Savings can range from thousands of dollars to millions of dollars annually, depending on the volumes handled.

### Solid Waste

Most industrial manufacturers in SIC's 34 through 37 generate both normal waste (paper, cardboard, wood, cans, etc.) and metal waste. By implementing waste recycling programs, the cost of solid waste disposal can be reduced or completely offset, the amounts sent to landfills will be reduced, and charity organizations can benefit. Pulp and paper companies such as Weyerhaeuser and Georgia-Pacific often purchase paper and cardboard for recycling. Wood can be ground up and sold as hog fuel at power generating plants, sold intact to commercial wood recyclers, or given to charities for their usage. Metals, such as aluminum, copper and steel, can be recycled in large quantities, occasionally to the original suppliers or their subsidiaries. Lubricating oil used in the milling process can be separated from metal chips and cooling water using centrifuges and sold to recycling companies. Depending on the area of the nation the facility is located in, metal and oil recycling may actually involve costs to the industrial manufacturer. However, these costs will be significantly lower than those associated with the hazardous waste disposal of metal contaminated oils or oil contaminated metals, neither of which can be dumped at a normal landfill site.

### **Part 6 - Tactics**

This section will take a brief look at some of the basic tactics that the energy manager will need to use to get projects funded and to gain participation from unwilling occupants. Implementing energy related programs can be very difficult for the energy manager. Many of the people involved will see little or no need for the programs the energy manager would like have implemented. In addition, even though the need can be identified clearly, the

program or project will, most likely, require funding. This section provides a discussion of the communications requirements and possible methods of obtaining the necessary funding to implement programs or projects.

### **Communications**

As previously stated, effective communications is one of the biggest and most powerful tools the energy manager can have when implementing a conservation program. By identifying usage and comparing that with something the average worker can relate to, greater emphasis will be placed on the objective. For instance, the personal computers at Boeing's Fabrication Division used enough power sitting idle during off-hours last year to provide 61 homes with electricity. By highlighting this fact in communications materials, more people participated in the program to conserve energy. During times when headcount reductions were the concern of everyone, relating energy costs to an equivalent number of heads helped demonstrate the need for conservation programs such as turning off lights during off-hours and reducing heating setpoints on HVAC systems.

Another problem often encountered is in the words we use when communicating with the rest of the world. Engineers are notorious for utilizing multisyllabic verbiage in presenting communications to other employees to emphasize issues we consider important. Stated simply, we use big words to make our point. The people the energy manager needs to communicate with are often offended by the use of complex words. The use of simpler more common words will reduce confusion and minimize the chances of a misunderstanding. There are two basic rules in communications, keep it simple and keep it brief!

### **Selling a Project**

The plants within the metals fabrication sector (SIC's 34-37) spend very little money on energy when compared to labor and material costs, refer to Figure 2.3. Production level machinery can cost as much as an entire year's utility costs but can increase production rates to levels that make equipment purchases far more profitable than any conservation or energy improvement program. As previously stated, capital rationing is a common practice where all projects and all direct and indirect costs compete for portions of the same funds. Plant managers prioritize the expenditure of those funds by first listing those items that must be paid for (such as materials, labor related costs, regulatory requirements, and utilities), followed by those items which improve productivity (equipment purchases, process changes) and finally by those items which will improve the condition of the plant (lighting & HVAC upgrades, etc.). Figure 2.4 illustrates the breakdown of capital expenditures between plant and machines. When selling a project to a plant manager, a need has to be identified with proposed solutions and repercussions of not following through. By relating the solutions to reductions in labor costs, productivity gains or environmental requirements, a project is more likely to be funded than if it simply provides a decrease in the utility costs. The more benefits to be gained, the more likely a program is to be funded.

There are a number of methods for evaluating the impact and benefits to be gained from a project. There is simple payback, internal rate of return, return on investment, net present value, and life cycle costing. The most effective method appears to be a combination of simple payback and life cycle costing where the total initial costs (construction, materials, and design) are combined with the difference in annual operating costs between the old and new systems (maintenance labor, materials, and energy costs) and are divided by the annual savings in energy. The end result is a modified payback rate expressed in years and represents something that most plant managers can understand. Internal rate of return and net present value are accounting terms that are not fully understood by engineers and managers alike. Invariably, one of the first questions asked by a manager is "How long is the payback period?". Internal rate of return and net present value do not provide this information. The return on investment is very close to the modified simple payback in that the total initial cost is divided by the total annual savings, including maintenance and energy savings less annual operating costs. Putting the costs and benefits in terms that are easily and clearly understood by the people responsible for making decisions is a must.

**Figure 2.3 - Capital Expenditures for Plant and Equipment  
SIC 34-37  
(Millions of Dollars)**

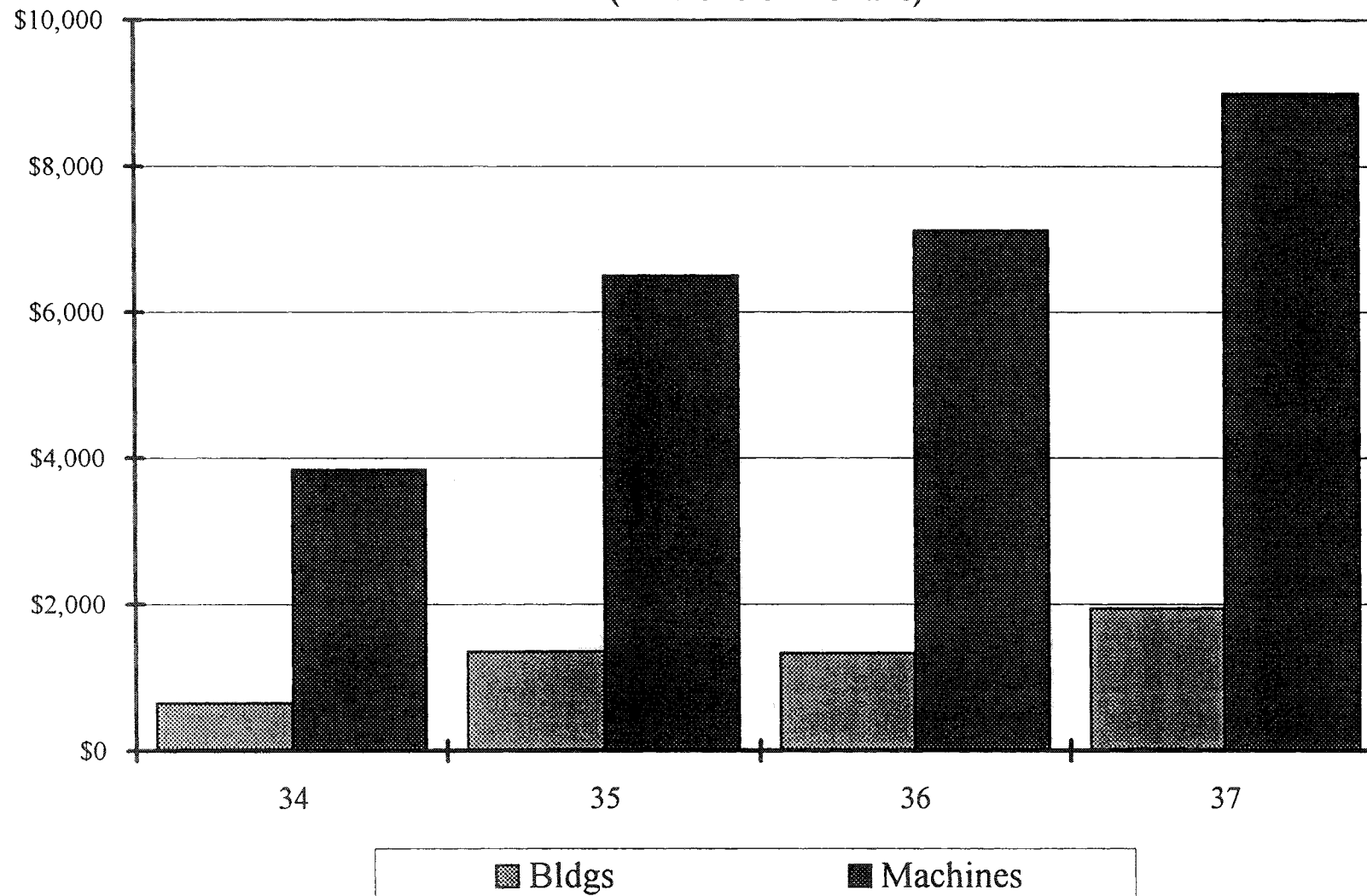

Source: 1991 Annual Survey of Manufacturers, M91(AS)-1  
U.S. Department of Commerce

**Figure 2.4 - Breakdown of Costs as Portions of Total Value of Products Shipped by SIC  
(Millions)**

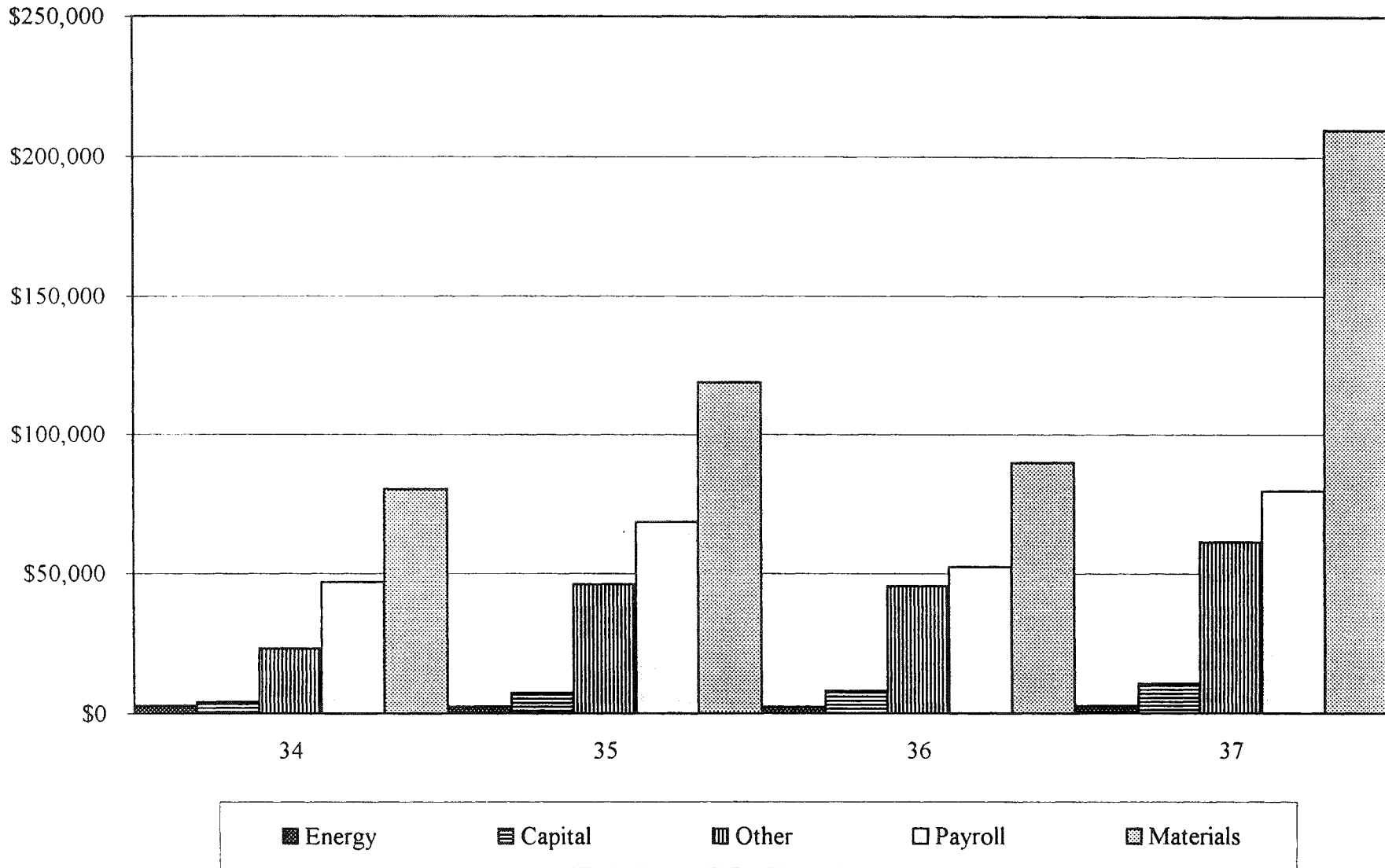

Another factor that can help get a project funded is if it can be shown to benefit more than one tangible area, particularly if it can be shown to have tangible benefits to production. For instance, lighting upgrades are often credited with improvements in morale and increases in productivity. But how often have lighting improvements been credited with improved detection of manufacturing flaws? Following the lighting upgrade in one of the buildings at Boeing's Auburn plant, the number of rejected parts increased. Analysis showed that the increased lighting levels allowed inspectors to identify less obvious imperfections in the material surfaces resulting in a higher number of rejected parts. It was found that improving the lighting had resulted in quality improvements in the end product that have been noticeable all the way through assembly and painting. By demonstrating to subsequent production managers that increased lighting can result in both increased product quality and reduced production labor required for rework, as well as reducing energy costs, decreasing maintenance costs and increasing lamp life, the managers were more willing to spend money on lighting upgrades.

Finally, a project should be able to sell itself. The more discussion required to convince a manager a project is worthwhile, the less likely it is to get the project funded. It may take some creativity on the part of the energy manager to identify all of the merits of a project. It may also take some digging to identify the negative repercussions if a project is not implemented. For example, in attempting to obtain funding for a relamp project, the building manager made the statement that the lights have been on for 5 years so it was obvious the lamp life did not apply. The response was to show the increase in the number of task lights installed over the past several years, and the number of calls to maintenance to replace burned out lamps. It was also stated that when the electricians were being used to install these task lights and replace lamps, they couldn't be working on more critical items. After some stalling, the manager agreed that the lights probably did need relamping and the funds were allocated to complete the project.

In summary, projects which can be shown to have an impact on production are more likely to get approved and funded than those which do not. Also, in presenting a project, keep the presentation short, keep the words simple and use terms that are familiar to those listening. Finally, the more diverse and tangible the benefits are, the better the likelihood of success.

## **Part 7 - Special Considerations**

There are some special considerations that need to be addressed that are common to all manufacturing and some that are specific to the Metals Fabrication Industry. In evaluating a product or system for applicability, the factors listed below need to be addressed. These factors include:

- Availability of resources
- Schedule
- Code, Regulation and Environmental Requirements
- Fabrication & Manufacturing Requirements
- Maintenance issues and Product or System expected life
- People & Safety concerns

### **Availability of resources**

Consideration must be given to the resources required to design, install, and maintain a product or system. It is important to identify during the initial evaluation stages whether the engineering can be performed in-house or if consultants are required, whether the product can be maintained by current staff or is additional training required or are highly specialized maintenance procedures necessary. Consideration also needs to be given to existing stock on-hand or within easy access. Installing a product that is not supported by spare parts readily available, means the product or system will be inoperable for extended periods of time when failures occur. This can seriously offset any energy savings if the product or system impacts production.

### **Schedule**

An important aspect of a product or system is the scheduling of the design and implementation. Not only must the resources be scheduled, but if the installation of the product or system impacts production, interruption to the production schedule needs to be evaluated and coordinated. This may mean that a product or system cannot be implemented until annual shutdowns or other scheduled downtime.

### **Code, Regulation and Environmental Requirements**

Several programs initiated recently addressed changing requirements in codes and regulations as well as environmental requirements, such as reducing energy usage and reducing waste discharges. Most engineers and consultants are aware of the codes and regulations regarding equipment design and installation, such as the National Electric Code, the Uniform Building Code, and the Occupational Safety and Health Act (OSHA). However, there are additional requirements that are specific to the metals fabrication industry. These additional requirements come in the form of manufacturing specifications that address all aspects of manufacturing and may require the approval of the regulating agency prior to modification. These regulating agencies can include the Federal Aviation Administration, National Highway and Transportation Safety Board, and the Food and Drug Administration. The product or system may also require approval or listing by an independent laboratory such as Underwriters' Laboratories. Obtaining the required approvals can involve a surprisingly long time and may require prototyping and testing prior to gaining approval. In general, manufacturers which need to comply with these additional requirements will have copies of the manufacturing specifications available or a source of those specification identified.

### **Fabrication and Manufacturing Requirements**

Very closely related to the previous section, is fabrication and manufacturing. It would be impractical to install a product or system that cannot support the fabrication or manufacturing process. For example, in the cutting and shaping stage, motors, motor drives, bearings, hydraulics and other systems must be able to withstand high impact loads, high torque, high speed, and/or highly varying loads. As machine routing bits move through the material, the loads imposed on the motors can vary based on the depth of the cut, the speed through the material, the sharpness of the bits, and the density of the material. Care needs to be exercised when installing variable speed drives on the machine spindles to ensure the drive can handle the loads. Motors may need specially designed windings and/or bearings to handle the high impact loads.

One aspect of the metals fabrication industry is that anything installed in the manufacturing area must be capable of withstanding contamination by metal dust, oil mist, and various degrees of corrosive materials. The manufacturing area is one of the most hostile areas in which a machine or piece of equipment can be installed. Constant housekeeping is a problem that plagues many maintenance organizations and can determine the life of a machine. Other concerns include noise (audible, electrical and radio frequency), vibration, power system harmonics, and power system outages. Manufacturers cannot afford to install equipment that is sensitive to the environment in which they will be placed.

### **Maintenance Issues and Product or System Life**

Maintenance is one of the areas that many consultants and engineers ignore when recommending the use of a product or installation of a new system. The type of maintenance a product or system requires should be compatible with existing skills within the maintenance organization. If the product requires specialized maintenance not available at the plant, then the cost of obtaining that service needs to be included in any cost analysis. The costs associated with training of maintenance personnel needs to be included in the analysis. Another concern is the expected life of the equipment and how susceptible is the equipment to failure if the maintenance schedule is extended for various reasons. In the manufacturing arena, machine or system availability translates into income. If the machine or system is not available for manufacturing products because a piece of hardware (such as a motor or motor drive) is broke or inoperable, then the manufacturer is losing money.

### **People and Safety Concerns**

Safety is one of the foremost concerns of manufacturers, not only in the manufacturing areas but also in the office areas. Indoor air quality, lighting quality, and noise are issues that need to be addressed in both the manufacturing and in the office areas. For example, the installation of metal halide lighting fixtures may present a point source lighting problem, if the background is very dark, causing increased eye strain on the employees. Transitioning from well lit areas to relatively dark areas can represent physical safety problems when employees are required to move around very large machines where shadows can be a very real problem. In manufacturing finishing areas, there is a need to provide adequate ventilation in a variety of processes. Tanklines may have highly noxious fumes that need to be extracted constantly and paint booths may have explosive vapors that need removal. Modifications to the HVAC system will need to address these issues in that the ambient air pressure within these areas may need to be negative in relation to the surrounding areas. Failure of the ventilation systems can have potential catastrophic effects. Changing a chemical process not only needs to address environmental issues such as hazardous waste disposal, but also manufacturing environment issues such as fume generation and mixing of fumes with those generated by surrounding processes. The need for redundant systems and isolation of incompatible mixtures can significantly change cost analyses.

Many of the issues described above need to be addressed in the evaluation of a product or system when it is in the proposal and evaluation stages. To address these concerns after a product has been selected and construction has commenced can lead to excessive first costs and potential loss of any monetary benefits. Also, non-monetary issues such as safety and the effect on personnel need to be addressed at the early stages.

### **Part 8 - Summary**

This section provided a brief discussion into many of the aspects of energy management encountered in the metals fabrication arena. We have included a discussion on the qualifications necessary to be an effective energy manager, the functions a typical energy manager performs, and some of the tactics necessary to sell a project or program to senior management. We have included a discussion on some of the opportunities available to reduce costs and improve energy efficiency of a facility. Within the limitations of this paper, it is impossible to list all opportunities available within the metals fabrication industry, the industry is simply too diverse. An effective energy manager or energy management team is constantly reviewing utility usage and costs, where and how those utilities are used, touring the facility looking for opportunities, and communicating progress. Improving the efficiency of a facility is not a straight forward process than can be described by a specific series of actions to be taken. Rather it is a continuous process that is constantly in review. The energy manager needs to set goals, develop a plan for reaching those goals, implement the plan, track progress towards those goals and allow for change along the way. While researching for this paper, it was found that a significant number of opportunities were identified by the employees and management at various plants. The energy manager needs to recognize that his job is not a solo performance. Some of the best resources available can be found in the people who work at the facility.



## CHAPTER 3 - EXTERNAL INFLUENCES

### Part 1 - General

This section will look at a few of the various government programs and policies established to assist or motivate industry to participate in energy conservation programs as well as utility demand side management programs. This section is illustrative of the types of programs available to the Plant Energy Manager and is not all encompassing. This section will discuss the Energy Policy Act of 1992, the Environmental Protection Agency's Green Lights and Energy Star programs, U.S. Department of Energy's Motor Challenge program and utility demand side management programs. To be an effective energy manager, there is a need to be aware of what is happening external to the plant that could have an impact on a facility's energy usage and utility costs. To date, most legislation enacted has dealt with environmental issues. As energy demands become greater and excess energy capacity becomes scarcer, it is feared that government will try to closer regulate how industry utilizes energy, to the extent of attempting to mandate energy efficiency levels. Indications that we may be moving towards greater government involvement in industrial energy efficiency include the Energy Policy Act of 1992 and the development of comprehensive state energy codes.

Each president since Franklin Roosevelt has expressed concerns in reducing the national energy usage and making the United States less dependent upon foreign energy resources. Presidents Nixon and Ford used Project Independence, President Carter had the 1977 National Energy Plan, President Reagan implemented deregulation of oil, while President Bush used the Energy Policy Act of 1989 and the Clean Air Act Amendments of 1990 to set policy on energy usage and energy efficiency. The final product of the Bush Administration and the Congress is the Energy Policy Act of 1992 (EPAct). EPAct influences all aspects of energy usage, from the roles government will play, how states will address regulation, where utilities will expend resources to how manufacturers will test and label equipment.

In discussing both EPAct and other programs with a number of industry representatives, it is generally felt that the government does have a role in reducing the energy usage throughout the United States, but that this role should be more as an advisor or as an eliminator of "roadblocks" or other obstacles. Several organizations within state and federal governments can be resources that should be available to all manufacturers. For example, the Department of Energy has Energy Analysis and Diagnostics Centers (EADC) established at 32 universities nation wide with a central database located at Rutgers University. Currently, each EADC performs energy audits for small to medium sized manufacturing facilities within their respective regions and provides recommendations to the manufacturer on how to improve the energy efficiency and, to some extent, the manufacturing efficiency at the facility. This is a very valuable resource for the smaller manufacturer who may not have the resources available to perform the audits and analyses internally. The only drawback to the EADC program is that it is not available for the larger facilities with more than 500 employees. Another example of a good resource is the Washington State Energy Office (WSEO). This organization operates The Motor Challenge Information Clearinghouse for DOE and also operates Electric Ideas Clearinghouse. Both of these programs allow access through electronic bulletin boards. They are both good sources of information as well as good platforms for open discussion with others. Unfortunately, Governor Mike Lowry of Washington State is cutting WSEO's staff by two-thirds in an attempt to reduce state operating costs. There has been discussion that WSEO will be cut entirely from future budgets which could have significant repercussions across the nation. This is an example of where the federal government could assist in removing an obstacle (lack of state funding) by taking over both programs in their entirety.

In The Reference Addition of the Energy Policy Act of 1992 assembled by Dan Williams, Mr. Williams provided an editorial that challenges lawmakers to act and the Federal Government to invest in energy. To quote Mr. Williams:

*"Now is the time for massive action. The iron is hot and waiting for the Federal Government to strike for the maximum benefit of all. Our country is in dire need of a policy of energy investment that will provide*

*jobs and a new infrastructure; investment that will pay for itself in energy saved and pollution avoided; and investment that will make us more prosperous, secure and competitive in today's marketplace."*

He later says;

*"If the lawmakers do their part, Americans will make the system work. We will build a strong infrastructure now for billions less than it would cost after economic recovery. We will install new energy saving systems that will pay for themselves in a couple of years and begin to put money back into the system. We will be adopting a responsible environmental policy and lead the world in preventing trillions of pounds of pollutants from being expelled into the atmosphere."*

Mr. Williams is correct in his statements that the best time to act is now and that Americans will improve energy usage if lawmakers do their part. However, lawmakers and lobbyists need to recognize that the manufacturing industry will make decisions based on good business sense in the current manufacturing environment and not on esoteric objectives or predefined formulas which are economically unrealistic. Nor will these decisions be subject to a readily definable formula that will remain constant from one manufacturer to the next or from one generation to the next.

## **Part 2 - Energy Policy Act of 1992**

The Energy Policy Act of 1992 (EPAct) covers a wide range of topics, from operation of Federal Buildings to residential hot water heaters, equipment labeling and testing practices to utility cost recovery for demand-side management. This section discusses the Energy Policy Act of 1992 as it applies to the manufacturing industry. This does not address the many sections on residential, federal buildings, alternative fuels and other non-manufacturing industry topics.

There are thirty chapters or Titles in the Energy Policy Act of 1992, but only five have any significant application to industry. These five areas of concern are listed below:

Title I	Energy Efficiency
Title II	Natural Gas
Title VII	Electricity
Title XXI	Energy and Environment
Title XXII	Energy and Economic Growth

In Title I, there are several sections of interest, but three in particular. Section 111 deals with encouraging electric utilities to participate in conservation and energy efficiency projects by recommending the state regulatory agencies allow utilities to recover their costs for implementing applicable programs. What this means to the industrial customer is that if the serving utility is actively involved in demand-side management (DSM) programs such as energy conservation, energy efficiency and/or load management, that utility is allowed to recover the costs of those programs through its rate schedules. Although this is a good incentive for the utility to participate in demand-side management, it penalizes the nonparticipant.

Section 112 deals with energy efficiency grants to state regulatory agencies by authorizing up to \$250,000 for each authority to encourage DSM programs. These grants may also be used for assistance to qualifying non-profit organizations participating in Dept. of Energy's Weatherization Assistance Program. Two things to note here, first is the amount and second is the recipient. Any effective program will exceed \$250,000 by orders of magnitude. The grant is to the state regulatory authority, not the state energy office. In fact, the various states' regulatory authority is often at odds with both the utilities and industries within the state's jurisdiction

Another section of interest is Section 122. This section sets forth testing and labeling procedures and efficiency requirements for package air conditioning and heating units, warm air furnaces, packaged boilers, water heaters, hot water storage tanks, heat pumps and general purpose electric motors. The duration from enactment of EPAct to the effective date of implementation varies from fixed dates such as January 1, 1994 for small commercial packaged air conditioning and heating units, up to 84 months for electric motors requiring listing by independent

labs, such as Underwriters' Laboratories. The electric motors addressed in EPCa are standard frames from 1 hp to 200 hp. Table 3.1 shows the nominal full-load efficiency these motors must meet.

No. of Poles	Open Motors			Closed Motors		
	6	4	2	6	4	2
Motor Horsepower						
1	80.0	82.5		80.0	82.5	75.5
1.5	84.0	84.0	82.5	85.5	84.0	82.5
2	85.5	84.0	84.0	86.5	84.0	84.0
3	86.5	86.5	84.0	87.5	87.5	85.5
5	87.5	87.5	85.5	87.5	87.5	87.5
7.5	88.5	88.5	87.5	89.5	89.5	88.5
10	90.2	89.5	88.5	89.5	89.5	89.5
15	90.2	91.0	89.5	90.2	91.0	90.2
20	91.0	91.0	90.2	90.2	91.0	90.2
25	91.7	91.7	91.0	91.7	92.4	91.0
30	92.4	92.4	91.0	91.7	92.4	91.0
40	93.0	93.0	91.7	93.0	93.0	91.7
50	93.0	93.0	92.4	93.0	93.0	92.4
60	93.6	93.6	93.0	93.6	93.6	93.0
75	93.6	94.1	93.0	93.6	94.1	93.0
100	94.1	94.1	93.0	94.1	94.5	93.6
125	94.1	94.5	93.6	94.1	94.5	94.5
150	94.5	95.0	93.6	95.0	95.0	94.5
200	94.5	95.0	94.5	95.0	95.0	95.0

Other sections which may be of interest include Section 123 which covers the testing, labeling and efficacy requirements for standard fluorescent and incandescent lighting fixtures. Sections 124 through 127 set a time frame for the Secretary of Energy to establish energy conservation guidelines for such things as HID lamps, distribution transformers, electric motors, luminaires, and office equipment. For the most part, the balance of Title I is dedicated to non-profit organizations and federal building energy management. The final subchapter, "Subtitle G- Miscellaneous" addresses, in part, the Energy Information Administration. Of particular interest is the frequency of surveying and reporting has increased to not less than every two years for generation and every three years for end usage.

Title II is a very brief chapter and amends the Natural Gas Policy Act of 1978 to the extent that foreign sources of natural gas from countries that participate in a free trade agreement shall be considered fairly and indiscriminately from domestic sources. What this means is that foreign sources cannot be taxed or levied against more than domestic sources.

Title VII - Electricity, is the section that has been the cause of probably the greatest controversy to hit the electric utility industry in a very long time. The early sections cover exempt wholesale generators, the effects of power purchases on cost of capital, public utility interests in cogeneration and the treatment of foreign utilities. Although these are important sections, it is Subtitle B- Federal Power Act, which covers amendments to the Federal Power Act (16 U.S.C. 824j), which has caused all of the hullabaloo. The sections covered under Subtitle B are the ones addressing wholesale wheeling of power. There is considerable discussion occurring at many different levels, including state regulatory agencies and FERC. This paper will not attempt to analyze the details or implications of Subtitle B. We are at the leading edge of electrical deregulation and many concerns on all sides of the issues have

yet to be resolved. The natural gas industry went through deregulation in the late 80's and early 90's and only recently have most concerns been ironed out. The electrical industry has yet to go through the pains of deregulation and the settling of all significant issues to the satisfaction of all impacted parties.

Title XXI predominately extends or implements studies and pilot programs for a variety of topics. These topics include cost effective technologies for renewable energy in buildings, natural gas and electric heating and cooling technologies, electric drive technologies, building energy efficiency, and others. The remaining sections apply to topics not the concern of most industrials, namely nuclear programs, superconductivity, electric and magnetic fields, renewable energy and ocean technology, among others. One of the sections of interest is section 2108, concerning energy efficient environmental programs. This section authorizes the pursuit of a 5-year program to promote improving the energy efficiency and cost effectiveness of pollution prevention technologies and processes, including technology transfer.

Title XXII is the final section that would apply to industry. This section pertains to the development of advanced manufacturing materials, techniques and technologies. It also addresses improving and integrating basic research and development efforts by industry, universities and the government. Although there are no firm results from this section, it does set a time schedule for plans to be completed.

In summary, the Energy Policy Act of 1992 was a big step in the right direction for Congress. It begins to address issues which have concerned industry and establishes schedules for continuing progress in a positive direction. One major point that EPAAct has going for it is it does not place an undue burden upon industry to improve its energy efficiency. Rather EPAAct attempts to provide solutions through authorizing programs to find cooperative solutions to today's problems. One of the main drawbacks is that EPAAct does not provide funds, merely authorizes the usage of funds.

### **Part 3 - The EPA Green Lights Program**

This section provides a discussion on the pros and cons of the EPA Green Lights program from the perspective of a major industrial manufacturer. Although the Green lights program involved participation of utilities, industrial manufacturers and various product manufacturers, this discussion will address the program only from the industrial manufacturer's perspective.

The Green Lights program sponsored by the Environmental Protection Agency is a collaborative effort between individual manufacturers and the EPA where the manufacturer agrees to replace all inefficient lighting systems with new more efficient lights and/or controls, providing it is economically viable. The entire program is based on the assumption that reducing the energy used for lighting will reduce the pollutants released into the atmosphere by reducing the amount of electricity that needs to be generated. Depending on the source of the electricity, this is a valid assumption. However, if the regional source is hydroelectric, there are no emissions to be reduced. The effectiveness of the program is questionable as there is no data distinguishing between those companies that performed lighting upgrades independently, as part of a utility DSM program or as part of Green Lights.

The Green Lights program is started at a specific company by an initial contact from a representative of EPA. If this initial meeting was successful, the next step would be to have a Memorandum of Understanding (MOU) signed by an officer of the company and the EPA. In this MOU, the company would agree to survey 100% of its buildings within a specified time frame, such as 3 years, and would also agree to upgrade the existing lighting systems wherever financially viable within a similar time frame. Unfortunately, financially viable was defined by the EPA as any project having an internal rate of return at least equal to the prime lending rate plus six percent. The payback period under this criteria is often greater than the useful life of the project. This program assumes that the company has unlimited funds and resources to perform the upgrades.

The Memorandum of Understanding states the following significant responsibilities of both parties.

The industrial manufacturer will:

- a. survey 100% of all facilities located in the U.S.,
- b. retrofit 90% of the square footage of its facilities for which retrofits meet IRR requirements, within 5 years of the survey,
- c. design all new facilities to meet ASHRAE/IES and U.S. DOE standards for lighting,
- d. annually document the improvements, and
- e. re-survey facilities and reanalyze options at each facility within 5 years after completing a retrofit.

The EPA will:

- a. assist manufacturer in adopting cost-effective lighting technologies
- b. seek cooperation with government institutions to remove unjustified barriers and reduce costs and risks of high efficiency products.
- c. develop workshops and training courses.
- d. develop a decision support system designed to help the manufacturer complete surveys and evaluate options
- e. create a Green Lights Allies program listing qualified contractors, financing sources, and independent organizations.
- f. create a Green Lights Utility Allies program to help find rebates and technical assistance.

There are a few areas that the industrial participant needs to be aware of. First, it is the responsibility of the industrial manufacturer to fund the projects and obtain assistance, if available, from the serving utility's demand-side management programs. EPA provided no funds as part of the agreement. When a manufacturer signs up to be a Green Lights participant, they must be ready to dedicate the funds necessary to complete the program, which means the manager making the decision must be aware of the magnitude of the costs involved. . Several utilities are reducing DSM programs and are offering significantly reduced rebates for energy conservation and energy efficiency type programs. However, there is an escape clause in the Green Lights MOU which allows the industrial manufacturer (or EPA) to terminate the program with no repercussions.

Second, there are some faults in the EPA decision support software. The software does not take into consideration changing the type of fixtures as a listing of available alternatives, such as replacing high-bay fluorescent with HID type fixtures. Other considerations not included are point-source lighting and shadowing effects, reflections on video displays, color rendition and contrast ratios. All of these are important considerations in the design of a lighting system for a building or area. Lighting system design has been referred to as an art by some and a complicated design process by others. There are a number of books that describe the design process and the criteria involved. In addition to those books identified in Chapter 2, the Illuminating Engineering Society's Lighting Handbook and the California Energy Commission's Advanced Lighting Guidelines Handbook are two excellent sources on lighting design.

#### **Part 4 -EPA's Energy Star Buildings Program**

This program is a follow-on the EPA's Green Lights Program. Energy Star Buildings is a program that is very similar to the Green Lights Program in that the industrial manufacturer enters into a Memorandum of Understanding with the EPA to survey all buildings and install retrofits or upgrades where applicable, within a defined time frame and with a defined payback. This program will be fully operational in the fall of 1995. Where the Green Lights program focused all efforts on lighting systems, the Energy Star Buildings program focuses efforts on Heating, Ventilating, and Air Conditioning (HVAC) systems, chilled water systems, and electrical distribution systems. This program is a sequentially staged program with time schedules for each phase. The stages are:

Stage I	Green Lights
Stage II	Building Tune-up
Stage III	Additional HVAC Load Reductions
Stage IV	Upgrade Fan Systems
Stage V	Upgrade HVAC Plant and Electrical Distribution

The schedule proposed by EPA as part of the program is shown in Table 3.2, below

Table 3.2 - Energy Star Buildings Program Schedule

Milestone	Percent of Eligible Facility Space Where Upgrades have Begun or Surveys have been Completed	Percent of Eligible Facility Space where Profitable Upgrades have been Completed	Progress Report
6 Months			Yes
End of Year 1	10%		Yes
End of Year 2	20%	Complete all Pilot Building Upgrades	Yes
End of Year 3	30%	10%	Yes
End of Year 4	40%	20%	Yes
End of Year 5	50%	30%	Yes
End of Year 6		40%	Yes
End of Year 7		50%	Yes
End of Year 8			Yes

From the viewpoint of a major industrial manufacturer, this program has the same drawbacks as the Green Lights program, except on a much larger scale. The program is an attempt by the EPA to get building owners to improve the efficiency of the program at no cost to the EPA. The burden is all on the building owner; however, the program can be terminated at any time by either party.

One of the significant points where this program differs from the Green Lights Program is in the minimum payback rate. Section II.C. of the Memorandum of Understanding (MOU) defines a Profitable Upgrade:

*Profitable Upgrade. A combination of energy efficient technologies that maximize energy savings for a given building while maintaining or improving building comfort and indoor air quality, and;*

- 1. providing an annualized internal rate of return (IRR) after tax that is at least equivalent to 20 percentage points over a period of 20 years, or alternately*
- 2. demonstrating a net present value (NPV) greater than zero over a 20 year period, using a discount rate of twenty percent.*

The hazard associated with this is the building owner MUST be aware of the cost implications of this paragraph and the requirements of the rest of the MOU. It would behoove the energy manager to prepare a detailed cost estimate of the implications of the program BEFORE committing to this program and ensuring the plant manager is aware of the costs before agreeing to the MOU. Another precautionary step the energy manager should take is to contact the local utility company and determine if financial assistance is available and to what extent is the assistance available. Portions of the requirements of the MOU may not be included in a utility's DSM program.

The following is a summary of the commitments of both parties signing the Memorandum of Understanding.

The Energy Star Buildings Partner (the industrial customer) agrees to do the following:

1. Assign a Project Director
2. Implement and complete a Pilot Building Upgrade within the first 2 years,
3. Survey and Upgrade U.S. facilities according to schedule in Table 3.2, above,
4. Replace Major Systems upon Retirement or Failure with most efficient and cost effective alternative,

5. Maintain or Improve Building Comfort and Indoor Air Quality
6. Ensure New Construction complies with program requirements
7. Develop Energy Awareness Program
8. Provide progress reports according to schedule in Table 3.2, above.

The EPA agrees to:

1. Provide technical support, guides, case studies, analytical tools, and technical hotline.
2. Provide educational materials to facilitate communication and marketing of the program
3. Provide public recognition
4. Provide recognition of those buildings with exemplary energy reductions.

### **Part 5 - Motor Challenge program**

This program is a joint effort between the U.S. Department of Energy, industry, motor/drive manufacturers, distributors and other participants to get information to the end user on methods for improving motor and motor driven system efficiency. The purpose of this program is to stimulate the market to lower the price of efficient motor systems and system components in an attempt to gain market penetration. This program differs significantly from the EPA programs in that the industrial manufacturer is not committing to specific levels of involvement, specific payback rates, or specific time frame for implementation. The commitments made by both parties are listed below.

The Motor Challenge Partner agrees to:

1. Incorporate energy efficiency as a necessary consideration in the design, purchase and operation of electric motor systems.
2. Educate employees about the benefits of energy-efficient motor systems.

The DOE agrees to:

1. Establish and operate a Motor Challenge Information Clearinghouse
2. Coordinate the Motor Challenge Showcase Demonstrations that highlight specific examples of how industrial facilities can improve their energy efficiency, productivity, and environmental performance.
3. Provide recognition to Motor Challenge Partners for demonstrating leadership through the development and implementation of innovative electric motor system strategies.
4. Sponsor workshops and training programs on energy-efficient motor systems.
5. Work to remove any market barriers that inhibit the use of energy efficient motor systems.

The Showcase Demonstration portion consists of a team which will develop a specific electric motor system strategy to improve an industrial facility's performance. This is a voluntary portion of the program and is designed to provide case study type information to members of Motor Challenge.

### **Part 6 - Demand Side Management**

Utilities have been involved in demand side management (DSM) programs for a number of years. DSM is a term used to identify programs sponsored by a utility which concentrate on changing the end users usage through a variety of methods. The Electrical Power Research Institute (EPRI) completed a study of DSM programs around the country in 1990 and again in 1992. In this study eleven types of programs were identified below.

1. Audit and Building Envelope programs. Includes programs dealing with industrial energy conservation, building shell improvements, energy analyses, productivity audits and process efficiency assessments.
2. Heating, Ventilating and Air Conditioning (HVAC) programs. Includes programs dealing with space heating cooling ventilation and air quality equipment and systems.
3. Lighting programs. Includes programs dealing with efficient lamps and fixtures, task lighting, outdoor lighting, and lighting control systems.

4. Efficient Equipment and Appliance Programs. Includes programs dealing with water heaters, refrigeration equipment, food preparation, dishwashers, clothes washers and dryers, process and fabrication equipment, and manufacturing support.
5. Thermal Storage programs. Includes storage space heating, storage water heating, storage air conditioning and storage refrigeration systems.
6. Load Control programs. Includes programs involving utility control of customer loads or the promotion of facility energy management systems.
7. Economic Development programs. Includes programs that attempt to attract industry to, or retain industry within, an area by offering enhanced services or by implementing competitive pricing strategies.
8. Special Rate programs. Includes programs that offer non-standard industrial rates, such as interruptible or time-of-use rates, that are not associated with specific technologies.
9. Standby Generation programs. Includes programs that promote customer cogeneration or utility dispatchable standby generation equipment located at the customer site.
10. Motor and Motor Drive programs. Includes programs involving high-efficiency motors and/or electronic adjustable speed drives.
11. Power Quality and Conditioning programs. Includes programs that involve equipment for decreasing power disturbances or controlling power conversions or utility services designed to solve customer power quality problems.

EPRI has estimated over 145,000 industrial customers participating in one or more of these types of programs in the seven major regions of the U.S. Figure 3.1 shows the number of programs by type while Figure 3.2 shows the number of programs implemented since 1980. Table 3.3, below lists the industrial participation in 1991 by region. Part of the reason for the low participation by industrial customers in the Northwest are the traditionally low costs for power, ranging from \$0.027 per kWh to \$0.042 per kWh. The low costs make payback rates much worse than in other areas of the nation where utility rates are significantly higher. Also, the Northwest accounts for approximately 5% of the total number of programs offered whereas most of the other regions account for 10%-15% each.



Figure 3.1 - DSM Programs by Category

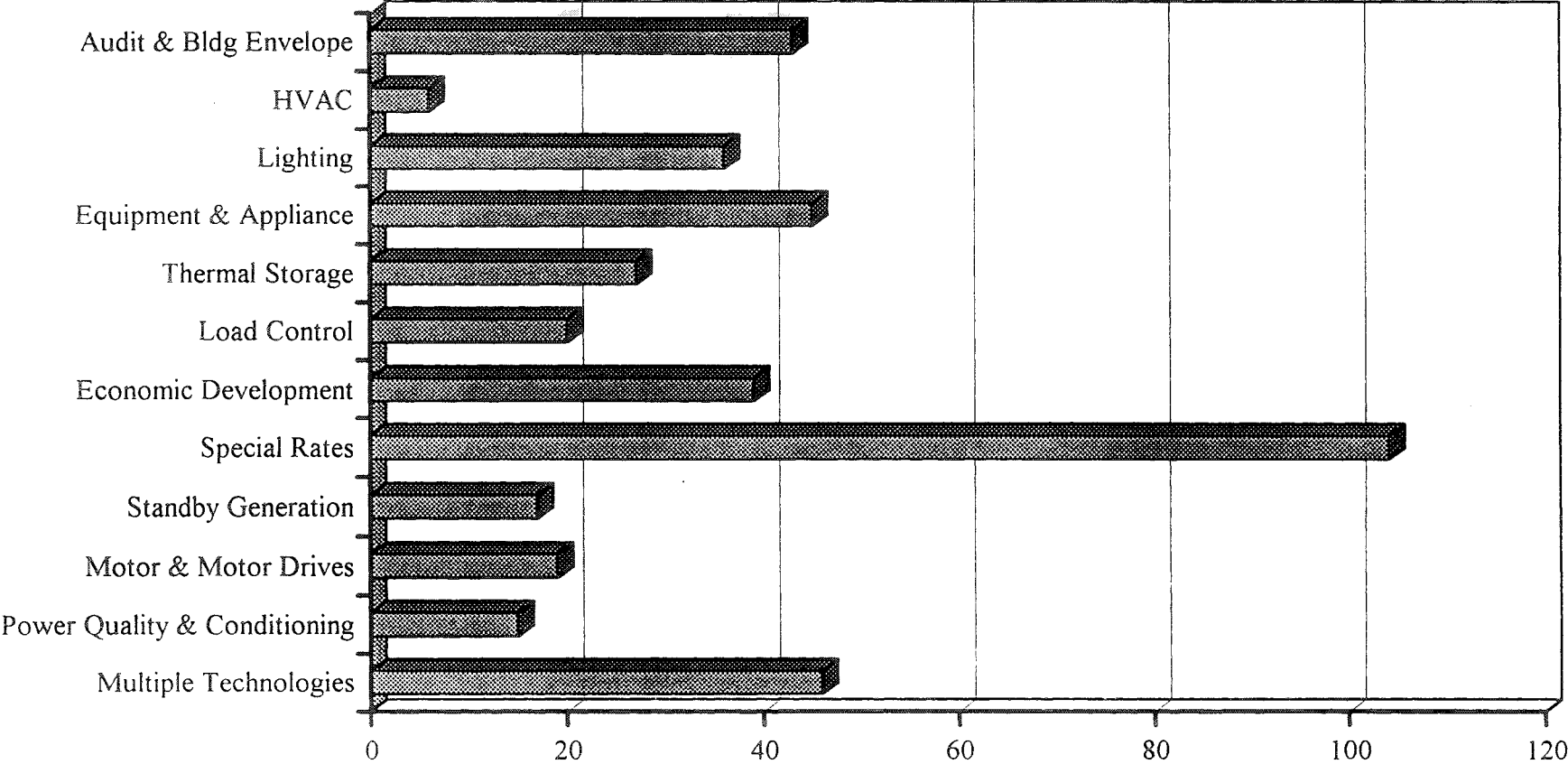

Figure 3.2 - Reported Industrial DSM Programs by Start Date

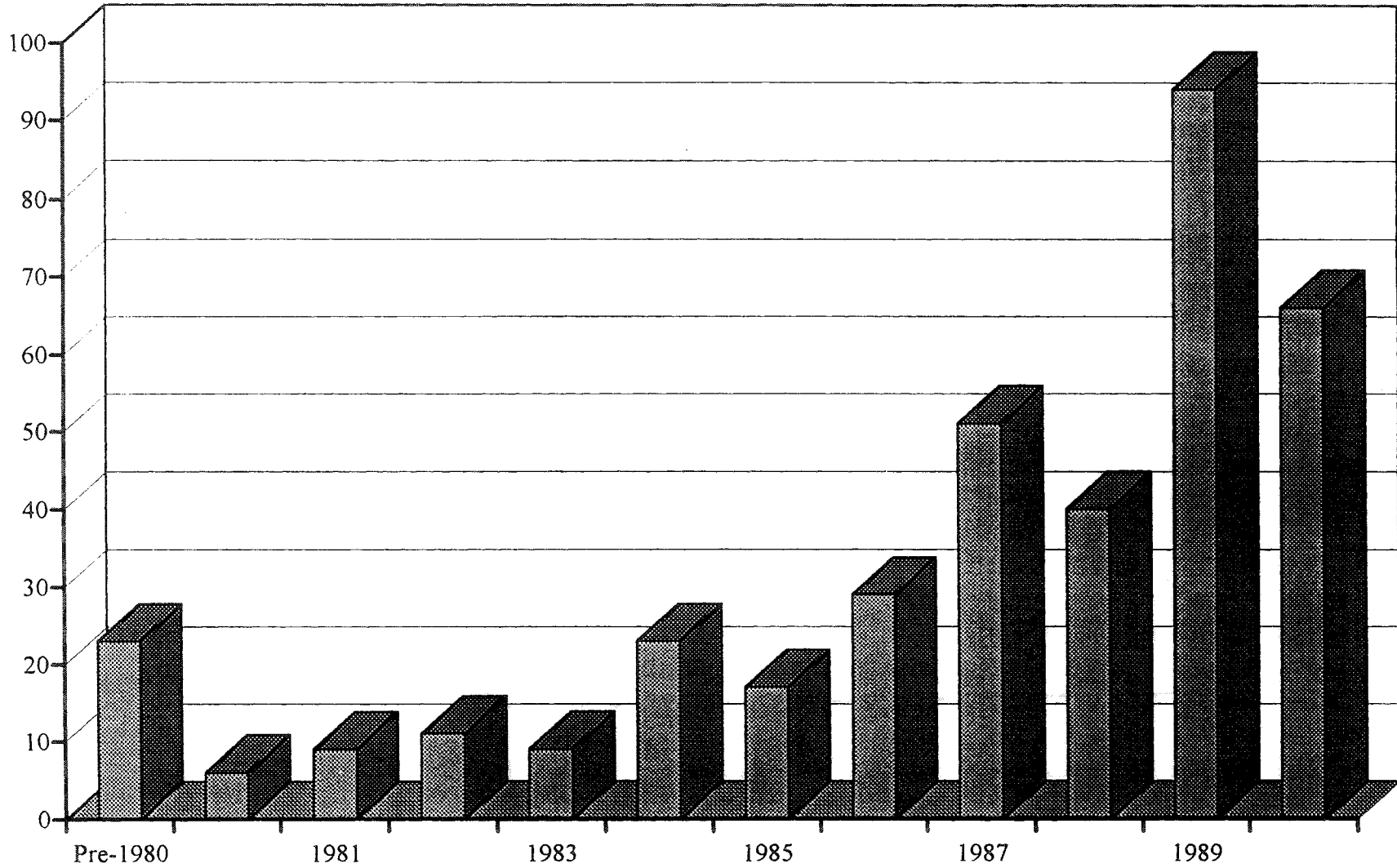

Figure 3.3 - Total Energy Usage by End Use for SIC 34-37

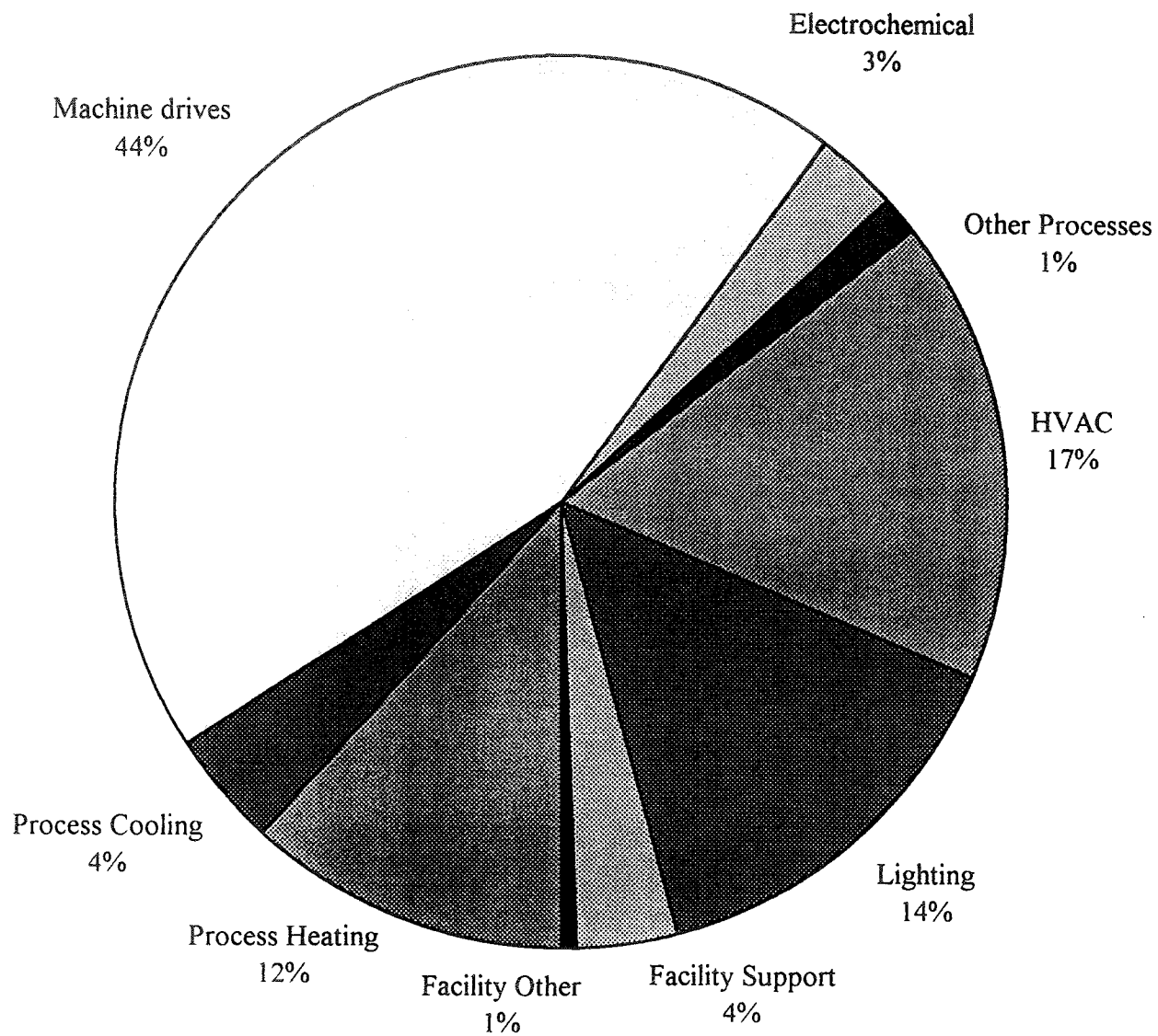

Table 3.3 - Industrial participation in DSM by EPRI region

Region	Number of Participants
Northeast	14,873
West	10,574
West Central	9,105
Southeast	8,260
South Central	3,822
East Central	2,477
Northwest	627

A recent report by Nadel and Jordan (Designing Industrial DSM Programs That Work, 1993) identified several reasons why industrial DSM programs fail. The reasons mentioned include:

- Capital rationing, where limited funds are established for all efforts, including maintenance, equipment purchases, environmental remediation, emissions control, and energy, each of which must compete with all others for a share of the funds.
- Non-strategic, energy is such a small portion of the cost to manufacture that it is often viewed as inconsequential.
- Stringent payback requirements, most industrials require one to three year payback rates for energy-efficiency type projects
- Interruptions to manufacturing during implementation, DSM programs often require system down-time to be installed. The trade-off between lost production and energy saved is extremely onesided with energy frequently on the losing side.
- Lack of awareness and on-hand expertise, many industrials are reluctant to allow outsiders into their facility to improve cost efficiency because they are not aware of the possibilities. It should be noted that skepticism by the industrials and overstatement of benefits and payback by outside consultants has also contributed to the problem.

Although Nadel and Jordan found the industrials were lacking in expertise in regards to DSM, it should also be noted that utilities are also lacking in qualified expertise and may be lacking in interest. A good indication can be found when looking at the utilities and the number of programs offered. John Studebaker identified 3,245 utilities, including private, municipal and cooperatives, in his book Slashing Your Utility Bills. The 1990 study by EPRI identified a potential of only 762 utilities which may have DSM programs involving industry. In 1992, EPRI received responses from a survey questionnaire mailed to all 762 utilities from 666 utilities and represented a total of 2,321 programs offered, with over 145,000 industrials estimated to be participating. This means only 21% of the total number of utilities are believed to have DSM programs.

There may have been several reasons for the low numbers including lack of personnel to administer DSM projects or lack technical expertise to develop and maintain the programs. If DSM programs are to be implemented on a broad scale, greater interest and expertise is going to have to be demonstrated by the serving utilities.

Of the eleven types of programs offered, the ones which have the most applicability in the metals fabrication environment include HVAC, Lighting, Efficient Equipment, Special Rates, Standby Generation, and Motor and Motor Drive programs. Building envelope programs apply to some extent to the industrial manufacturer. Figure 3.3 shows the total energy usage by end use for SIC's 34 through 37. Note that motors and motor drives, HVAC, and lighting account for 75% of the total usage. DSM programs which concentrate on improving these systems should have the greatest impact as well as the greatest reception by the industrial customer. Special rates programs have the additional merit of impacting all forms of usage, including office areas and have virtually no impact on production.

In their report, Nadel and Jordan recommended that to build a successful DSM program, a utility needs to partner with the industrials in their service territory during the development of the program. By listening to the industrial,

discussing all issues presented, and agreeing on a process for implementing and executing the programs, utilities should have greater success and greater participation.

### **Part 7 - Summary**

Although this chapter has not addressed all of the programs currently being sponsored by federal governments and various utility companies, it has highlighted a few of the more significant programs that an industrial energy manager would encounter. The impacts of EPCa on energy efficiency and wheeling of electricity are indicators that government is taking a more active role in energy usage in this country. Three programs offered by departments of the government which an energy manager is most likely to encounter have also been discussed along with the pro's and con's of each. It is felt that the Green Lights and Energy Star Building programs are based on good intentions but have eliminated any concern for changes in a company's ability to invest funds in non-production related projects. On the other hand, the DOE's Motor Challenge program does not require a commitment to invest, but does require a commitment to consider energy efficiency in any plant improvements. Utility sponsored DSM programs appear to be the better approach to improving energy efficiency in an industrial manufacturing plant.

## CHAPTER 4 - PROJECTING ENERGY END USE

### Part 1 - Introduction

The objective of this portion of the paper is to provide the tools necessary to estimate potential energy savings associated with expected improvements in the efficiency of both process heat and mechanical drive equipment in SICs 34 to 37, the metals fabrication industries.

Process heating and machine drive account for over 50% of total energy use in these industries, and are thought to represent a much larger percent of the total remaining energy savings potential in these industries. Other major uses include boiler fuel (16%) and HVAC and lighting (15%)<sup>12</sup>. Since substantial energy savings have already been achieved in boilers and HVAC systems and the methods to save additional energy are well documented (with the exception of so-called "task" lighting on the workpiece), they will not be addressed in this paper.

The study approach will be as follows:

- (a) Break down current total process heat and motor drive use into major end uses at the most disaggregate SIC level possible;
- (b) Estimate current market shares for each of the major technologies serving the identified end uses, and their current efficiencies;
- (c) Estimate projected market shares and projected efficiencies;
- (d) Calculate projected energy use if the projected shares and efficiencies were current shares and efficiencies, and determine energy savings potential by comparing the results with current total use.

### Part 2 - The Methodology

Models which attempt to predict likely energy use and savings in the industrial sector come in many varieties, with as many taxonomies as there are model builders and analysts. A useful approach is to categorize them according to the disciplines which gave rise to them:

- (1) Econometric models which use regression techniques to capture past relationships between the independent variables and the dependent variables of interest, and then use these derived relationships to map projections of the independent variables into projections of the variables of interest. Critics call this the "driving by looking only in your rear view mirror" approach to predicting energy use.
- (2) Engineering models which use explicit technology choice models driven by projections of the independent variables known to affect such choice. Critics call this the "driving with your eyes closed while asking directions from a clairvoyant engineer" approach.

The engineering modeling approach will be used to estimate energy savings potential, since they are the logical choice when the goal is to categorize and measure energy savings by the technology developments which give rise to them.

---

<sup>12</sup> MECS 1991 Survey data from "Manufacturing Consumption of Energy 1991," DOE/EIA.

First, no matter what your training -- economist or engineer -- energy analysts generally identify five generic causes for change in any measure of energy use.

- (1) Simple housekeeping savings, resulting from more care and attention to the functioning of existing equipment; this factor played a major role in the early years of the "energy crisis" when attention was first focused on energy savings;
- (2) Changes in the end use efficiency of a given technology -- e.g., substituting more energy efficient gas ovens or electric motors for older, less efficient ones. This usually involves trading a higher initial equipment cost for lower energy (and other) operating costs;
- (3) Changes in the technology mix of a given energy consuming end use -- e.g., direct resistance heating of small steel billets substituting for gas heated slot furnaces within the metal heating end use;
- (4) Changes in the end use intensities (BTU/unit of output for a product) as a result of changes in the process mix for a given product, e.g., less energy intensive mini-mill steel mill processes (electric arc/continuous cast) replacing integrated steel mill processes (blast furnace/BOF/ingot) in the production of otherwise indistinguishable steel coil and sheet products;
- (5) Changes in the mix of goods produced by the industrial sector in response to basic shifts in our consumption patterns. Analysts have concluded that nearly half of the reduction in industrial energy intensity in the U.S. can be attributed to changes in the market basket of goods we produce, as we move away from production of energy intensive commodity products to other, less intensive products.

This portion of the paper will limit itself to consideration of (2) and (3) above. Housekeeping savings do not lend themselves to the type of technology substitution analysis to be employed. Predicting energy savings resulting from changes in the basic ways products are produced ((4) above) can be done, but usually require the construction of elaborate process models of steel mills, pulp and paper mills, foundries, and the like,<sup>13</sup> an expensive and time consuming operation.

Predictions of "market basket" changes require still more complicated models of product choice and materials substitution, which again are beyond the chosen scope of this paper, despite their obvious importance.

In summary, ignoring housekeeping improvements and holding current end use intensities and market basket contents constant, the plan is to:

- (a) Map current estimates of energy use by standard industrial classification (SIC) available in the MECS<sup>14</sup> database into a more detailed breakdown of end uses, using a variety of data sources;
- (b) Estimate the current technology mix in place that now provides the end use services in these SIC categories, and their current average efficiencies;
- (c) Estimate changes in the end use efficiencies and technology mix that can be expected given reasonable assumptions regarding projected energy costs, equipment costs, and technical progress;
- (d) Calculate current total energy use, if these estimates characterized the present stock of energy using devices.

---

<sup>13</sup> See, for instance, the process models constructed at Brookhaven National Laboratories in the 1970s which formed the basis for the Electric Power Research Institute's "INDEPTH" process modeling system in the mid-1980s.

<sup>14</sup> U.S. Dept. of Energy, Energy Information Administration, Manufacturing Consumption of Energy, 1991 ("MECS"), DOE/EIA-0512(91), December 1994.

### Energy Use Characteristics of the Metals Fabrication Industries<sup>15</sup>

Predicting likely energy savings in the metals fabrication industries is made difficult because of two facts of life: the relative unimportance of energy as an input to these industries, and the lack of a dominant, unique set of energy using processes in these industries.

The situation in the so-called "commodity" industries is quite different. Figure 4.1 shows the relation between the so-called commodity industries, which provide the raw materials for the fabrication industries, and the fabrication industries themselves. As the figure shows, in most instances, there is a natural association between each of the commodity industries and the fabrication industries. The match-up is not perfect, however, particularly for the industries of interest in this study. For example, automobiles can use raw materials from all of the commodity industries.

The statistics of Table 4.1 document the first fact of life -- energy is a much more important input in the production of commodities than in the production of fabricated products. While the commodity industries account for only 20% of the value added to our products, they account for over 80% of the energy consumption. The same point can be made by comparing the energy intensities of the two groups; in 1991 the commodity industries averaged  $13.6 \times 10^3$  BTU per dollar value of product shipments, while the fabrication industries averaged only  $1.4 \times 10^3$  BTU per dollar. As a result, energy use in the commodity industries has been much more intensively studied than energy use in the fabrication industries. Thus, researchers interested predicting future savings in these industries can draw upon a wealth of data, while those of us interested in energy savings in the fabrication industries have little to start with.

The second fact of life -- that energy use in the commodity industries is concentrated in a few key processes that are specific to each industry -- can best be made by example. For instance, low temperature heating and drying tend to dominate the food, textile, wood, and pulp and paper industry uses of energy; medium temperature fluid heating the chemical and petroleum sectors, and high temperature melting and refining in the glass and primary metals industries. Figures 4.2 and 4.3 and Tables 4.2 through 4.4 make this point clearer for specific cases.

Figures 4.2 and 4.3 are representative flowcharts for sawmills and an integrated Kraft pulp and paper mill, whose energy use is in the low temperature end of the distribution. As Figure 4.2 shows, 70% of energy consumption in a sawmill is found in the wood drying process, while Figure 4.3 shows that the pulping and chemical recovery process consumes almost 75% of total energy in a typical Kraft plant.<sup>16</sup>

At the high temperature end of the spectrum, Tables 4.2, 4.3, and 4.4 show that roughly 50% of the energy used in a typical iron foundry is in the melting step and closer to 70% in the glass industry. Table 4.4 shows that over 50% of the total energy used in the aluminum industry is concentrated in a single process -- the electrolytic reduction of alumina ( $Al_2O_3$ ) to aluminum using the Hall-Heroult process.

---

<sup>15</sup> Here taken to be SIC 34 - Fabricated Metal Products; SIC 35 - Machinery, Except Electrical; SIC 36 - Electrical Machinery; SIC 37- Transportation.

<sup>16</sup> This includes the heat value of the feedstock consumed.



Table 4.1. - Energy Use and Intensity by Industry Type, 1991.

I) FABRICATION INDUSTRIES										
SIC	Name	Total Energy Use (1) (10 <sup>12</sup> BTU)	Total Energy Intensity (1) (000BTU/\$)	Total Net Electricity Use (1) (KWhx10 <sup>6</sup> )	Net Electricity Intensity (2) (KWh/\$)	Estimated % Electricity Used in Each End Use (3)				
						Motor Drive (%)	Electro-lytic (%)	Melting/Holding (%)	Heat/Dry/Cure (%)	Lighting/Other (%)
20	Food	953.0	2.4	49536.0	0.1	86.0%	0.0%	0.0%	1.2%	12.7%
21	Tobacco	24.0	0.8	1002.0	0.0	81.0%	0.0%	0.0%	0.0%	19.0%
23	Apparel	44.0	0.7	5645.0	0.1	78.6%	0.0%	0.0%	5.4%	16.1%
25	Furniture	67.0	1.8	4915.0	0.1	77.0%	0.0%	0.0%	4.9%	18.0%
27	Print & Publish	108.0	0.8	15629.0	0.1	69.4%	0.0%	0.0%	7.1%	23.5%
30	Rubber & Plastics	237.0	2.4	33908.0	0.3	71.4%	0.0%	0.0%	12.2%	16.4%
31	Leather	12.0	1.4	795.0	0.1	55.6%	0.0%	0.0%	0.0%	44.4%
34	Fabricated Metals	305.0	2.0	29772.0	0.2	36.8%	12.1%	0.0%	43.3%	7.7%
35	Industrial Machinery	235.0	1.0	29484.0	0.1	51.4%	0.6%	0.0%	36.0%	12.1%
36	Electric Equipment	196.0	1.0	29996.0	0.2	63.4%	0.0%	0.0%	14.6%	22.0%
37	Transportation	333.0	1.0	34721.0	0.1	44.0%	0.5%	0.3%	42.7%	12.5%
38	Instruments	98.0	0.8	12367.0	0.1	74.8%	0.0%	0.0%	10.9%	14.3%
39	Misc. Mfg.	31.0	1.5	3661.0	0.1	74.5%	0.0%	0.0%	7.8%	17.6%
		2,643								
II) CONVERSION INDUSTRIES										
22	Textiles	273.0	4.3	29532.0	0.4	82.4%	0.0%	0.0%	2.5%	15.1%
24	Wood	423.0	6.8	17878.0	0.3	76.1%	0.0%	0.0%	1.4%	22.5%
26	Pulp & Paper	2472.0	20.1	58896.0	0.5	93.2%	0.0%	0.0%	1.4%	5.4%
28	Chemicals	3040.0	11.1	129093.0	0.4	76.5%	19.5%	0.0%	0.5%	3.6%
29	Petroleum & Coal	2987.0	18.6	30782.0	0.2	94.9%	0.0%	0.0%	1.6%	3.6%
32	Stone, Clay, Glass	894.0	16.6	30814.0	0.5	72.1%	0.0%	13.3%	8.0%	6.5%
33	Primary Metals	2292.0	17.6	146276.0	1.1	40.0%	41.6%	14.1%	1.1%	3.2%
		12,381								
TOTALS		15024.0	5.5	65837.0	0.25	68.8%	11.9%	3.1%	7.6%	8.5%

(1) Source: U.S. Department of Energy, 1991 Manufacturing Energy Consumption Survey, Draft.

(2) Electricity use divided by value of industry shipments, U.S. Department of Commerce, Annual Survey of Manufactures, 1991.

(3) Source: Electric Power Research Institute, Electrotechnology Reference Guide, Revision 2, EPRI TR-101021, Revision 2, August 1992.

Table 4.2. The Nature of Interfuel and Interprocess Competition in the Iron Foundry Industry.

	Energy Use per Ton of Component Shipped ( $10^6$ BTU) <sup>a</sup>				
	Coke and Coal	Electricity	NG, Oil Etc.	Total	%
Melting <sup>b</sup>	5.46 <sup>c</sup>	1.67	1.60	8.73	48
Molding & coremaking	-	0.05	1.90	1.95	11
Casting, shakeout, cleaning, handling	-	0.11	0.75	0.86	5
Heat treatment <sup>d</sup>	-	0.30	0.70	1.00	6
Environmental control	-	0.55	0.50	1.05	6
Makeup air	-	0.03	4.50	4.53	24
Total	5.46	2.71	9.95	18.12 <sup>e</sup>	100
%	30	15	55	100	

a This is a synthesis of the best available information on the problem distribution of energy use. It confirms other data and extends the distribution to individual operations, a distribution that is not available from other data.

The component is 82% gray iron, 11% ductile iron, and 7% malleable iron.

b 70% cupola and 30% electric melting.

c To convert BTU/ton to kJ/t, multiply by 1.163.

d For 10% of the gray iron, 50% of the ductile iron, and all of the malleable iron.

e Base for computation of percentages in this table only. Source: ANL/CNSV-8.

- High energy intensity ( $18 \times 10^6$  BTU/ton) due to very low yields (40-50%) for the casting process.
- Low capacity utilization means little opportunity for expansion investments; primarily replacement or retrofit of aging equipment.

FIGURE 4.1

The Commodity and Fabrication Industries.

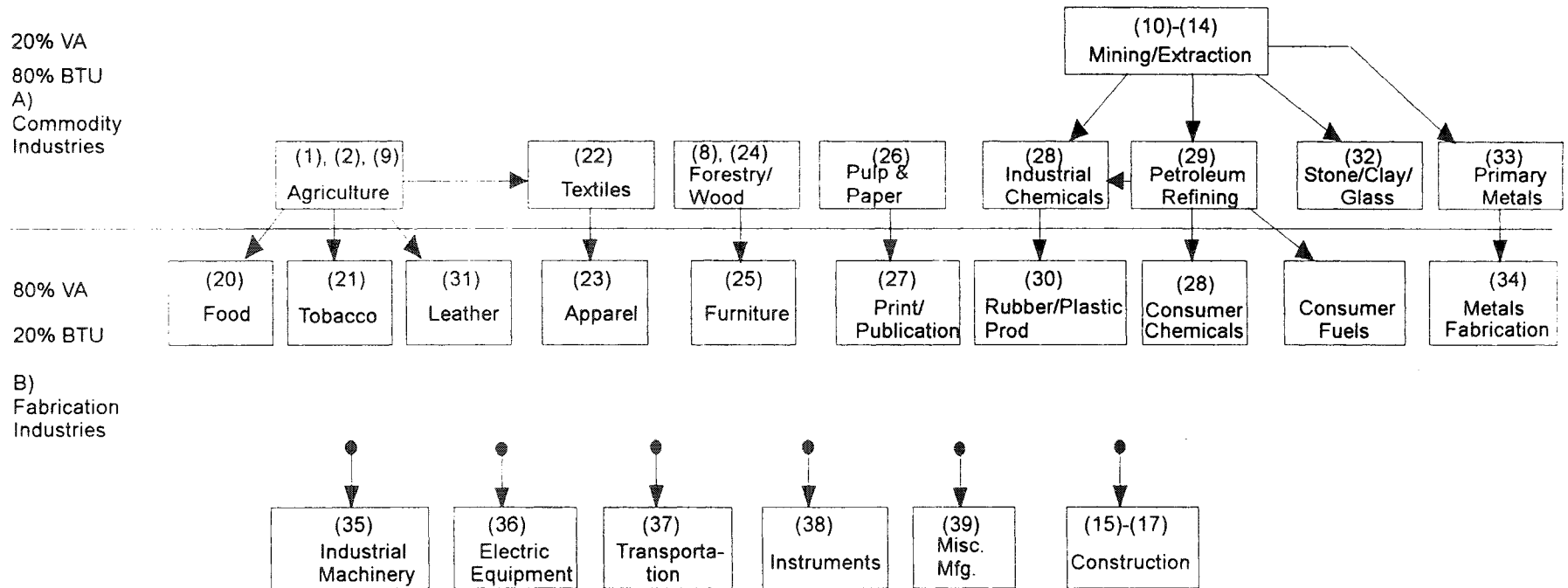

( ) = SIC code

Figure 4.2 - Sawmills and Planing Mills

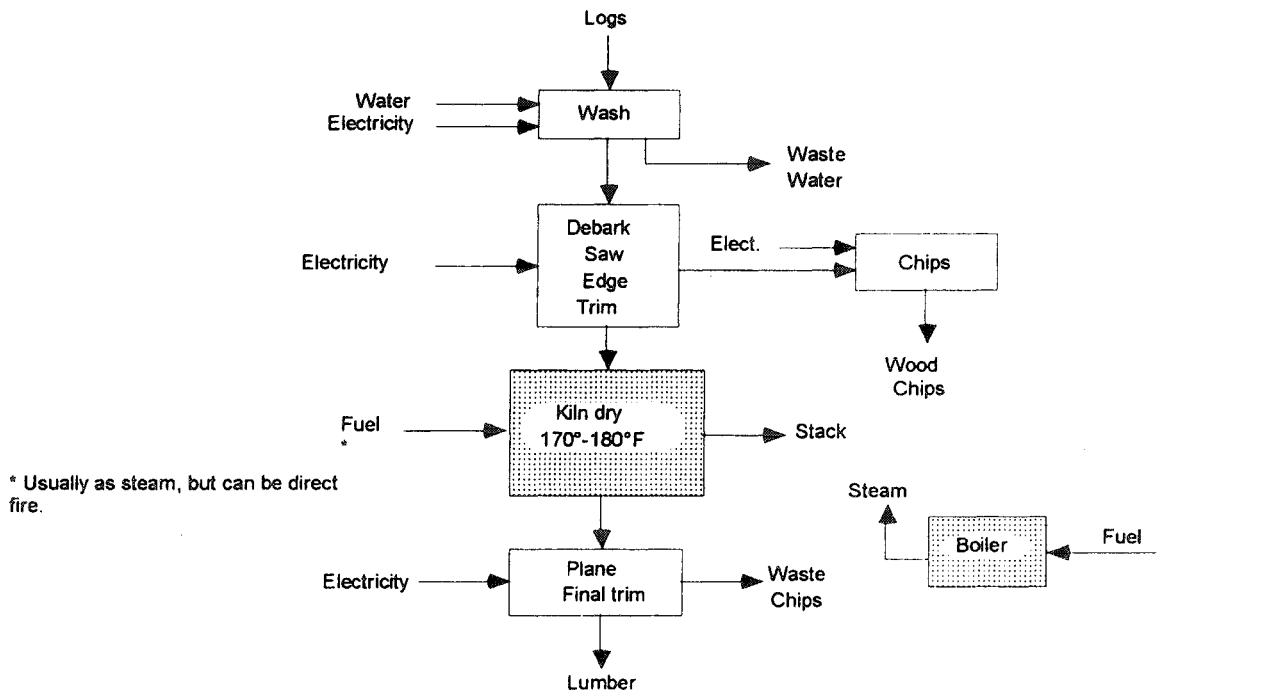

Source: Gas Research Institute 80/0104

Notes:

1. 70% of energy used is in kiln drying process. Converting to dehumidification drying using heat pumps results in 50% decrease in energy use.
2. About 35kWh/MBF used in kiln fans. This can be reduced by 40% with variable speed fans which decrease speed as moisture content drops. [Source: Bonneville Power Administration, "Additional Sawmill Electricity Energy Study", February 1987, Conservation Engineering Branch.]

Figure 4.3 Integrated Kraft Mill

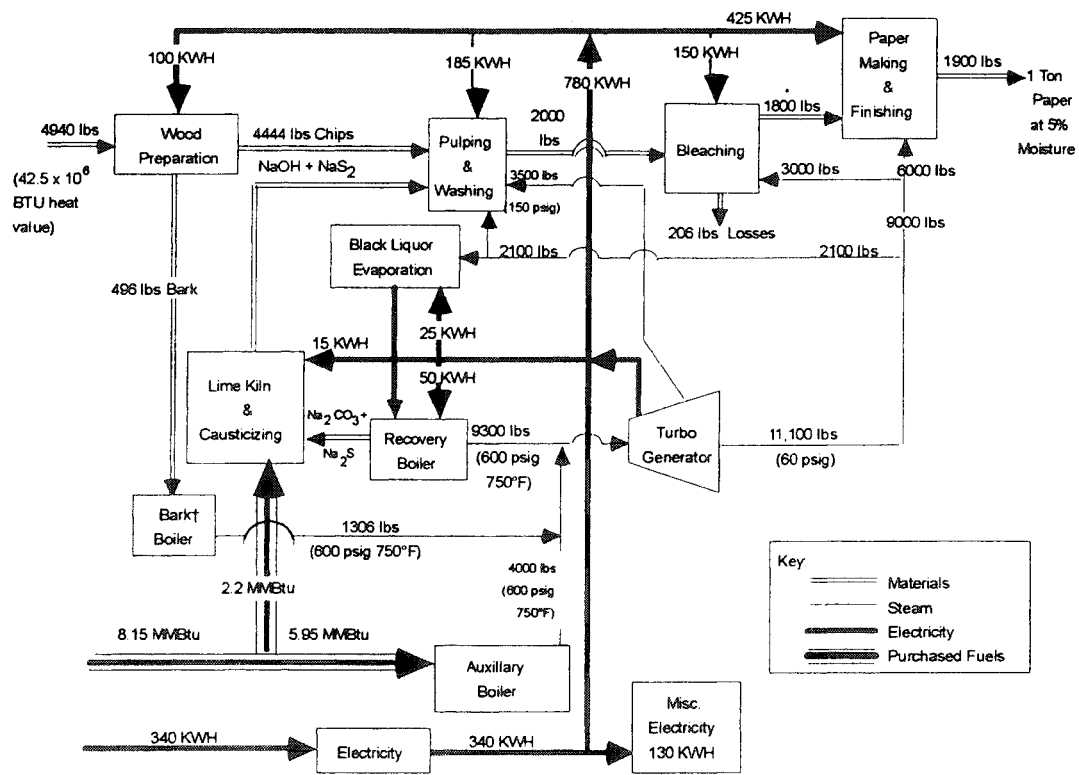

Source: EEA, Inc., Industrial Energy Productivity Project, Final Report, *The Pulp and Paper Industry*, DOE/CS/40151-1, p. 7.

Notes:

1. Co/self generation option here: some Kraft mills buy no electricity; sell it!
2. Freeze-dried option for black liquor to separate lignin, rather than burn it. Lignin can be used to replace oil/gas-based resins used in wood panels. Finland uses this type of process.
3. Black liquor gasification is being studied by industry; both high temperature (>850°C) and low temperature (<800°C) processes have promise of increasing electric power production by 20% to ~150kWh/ton pulp by use of "excess" heat, lowered capital and operating costs, an increased pulp yield. [Source: "Black Liquor Gasification", Swedish National Board for Industrial and Technical Development, Stockholm, Sweden, April 1992]

Table 4.3. Percent of Total Process Energy Consumption by Industry Segment and Process Step.

Segment	Batch Handling	Melting & Fining	Forming	Post Forming	Product Handling
Flat Glass	1.0	85.0	5.0	8.0	1.0
Containers	2.0	73.5	12.0	10.0	2.5
Pressed & Blown					
Hand ware	0.5	77.0	11.0	10.5	1.0
Machine ware	2.0	58.0	16.5	21.5	2.0
Lighting/Electronic	1.0	67.0	14.5	15.5	2.0
Glass Fibers					
Textiles	2.2	51.0	32.0	11.5	3.3
Wool	2.0	43.0	40.0	13.0	2.0

Source: PNL-5640/UC-951, June 1986.

Table 4.4. Energy Consumption by Unit Operations, 1985 (trillion BTU).

	Thermal ( $10^{12}$ BTU)	Power ( $10^6$ BTU)	Power (a) ( $10^{12}$ BTU)	Total ( $10^{12}$ BTU)
<b>PRIMARY OPERATIONS</b>				
Alumina Refineries				
Steam Raising	33	596	2	35
Hydrate Calcining	16	294	1	17
Primary Aluminum Smelting				
Anode Preparation	10	212	1	11
Electrorefining	0	59295	202	202
Other (casting, holding)	<u>13</u>	<u>0</u>	<u>0</u>	<u>13</u>
Subtotal	72	60397	206	278
<b>SEMI-FABRICATION OPERATIONS</b>				
Cast House-remelting	24	1451	5	29
Ingot Heating	22	0	0	22
Annealing	25	0	0	25
Rolling	0	1340	5	5
Extrusion	<u>13</u>	<u>357</u>	<u>1</u>	<u>14</u>
Subtotal	84	3148	11	95
<b>SECONDARY OPERATIONS</b>				
Scrap Preparation	3	17	-	3
Remelting	<u>7</u>	<u>51</u>	<u>-</u>	<u>7</u>
Subtotal	10	68	-	10
<b>TOTAL ALUMINUM</b>	166	63613	217	383

(a) Power converted to BTUs at 3413 BTU/KWh.

Source: Arthur D. Little, Inc., GRI-88/0025.

Ideas: (1) One process -  $Al_2O_3 \rightarrow Al$  -- uses 50% as much electricity as entire 34-37 electricity use! ( $4 \times 10^6$ )(15,600 KWh/ton) =  $62,400 \times 10^9$  KWh. (2) One improvement -- aluminum chloride process (Alcoa) could save one-third, or  $20 \times 10^9$  (ADC) as much as entire electricity use in autos.

In contrast, energy use in the metals fabrication sectors cannot be as easily studied, since energy use in these industries is spread over a wide range of processes which have much lower energy intensities than their commodity industry counterparts. Further, within each industry, there is a wide variation in the set of energy consuming processes found in a given establishment, with no one dominating energy use.

The fact that there are few "representative plants" containing common processes can be seen by examination of the results of a special Census of Manufactures study done several years ago<sup>17</sup> for the metalworking industries. The objective of the study was to determine by survey the distribution of metalworking operations in each of the four-digit SICs in SICs 34 through 38, and the foundry portion of SIC 33.

The results for two representative four-digit SICs are shown Tables 4.5 and 4.6. As the tables indicate, there is little commonality in the processes found in establishments even at this level of disaggregation.

Since there are no single energy intensive processes which are unique to these industries, the approach above will be to identify those common energy using processes found across these industries, and use these as the units of analysis.

#### AN EXAMPLE ANALYSIS -- SIC 3714

To illustrate the strengths and weaknesses of the approach, and to give further insight into the methodology, the calculations supporting the projection of energy savings -- for one end use, heat treating, in one four-digit industry, SIC 3714, auto parts and accessories -- will be presented.

##### STEP 1: Estimate current end use energy consumption, by fuel type.

Table 4.4 presents estimates of 1991 energy consumption broken down by end use and fuel type for SIC 3714. They are derived in the following way.

First, estimates of energy end use by fuel use were obtained from the MECS database, Table A-38. These numbers appear in the rows whose end uses are given in capital letters -- e.g., total inputs, boiler fuel, total process, process heating, process cooling/refrigeration, machine drive, electrochemical, and other. These estimates were further sub-divided into more detailed end use processes using information contained in the "IMIS" database<sup>18</sup> which contains estimates of the percent of each fuel use consumed by each four-digit industry for a much more detailed set of end uses. These end uses appear as the end uses listed in lower case row names. Each entry in the table for these select rows contains two numbers. The number in parenthesis is the percent of the particular fuel use estimated to be consumed in the indicated end use, taken from the IMIS database. The next number is the result of that percent being applied to the appropriate total energy end use in the capitalized rows. Thus, the estimate of  $0.36 \times 10^9$  BTU consumed by electric melting in Table 4.7 is obtained by multiplying the MECS estimate of total electricity use in process heating --  $3 \times 10^9$  BTU -- by the estimate of the fraction of the electric process heating use attributed to melting in SIC 3714 contained in the IMIS database -- 12%. The other estimates for both electricity and gas use were obtained in a similar manner.

---

<sup>17</sup> U.S. Dept. of Commerce, Bureau of the Census, "Selected Metalworking Operations: Subject Series," MC-82-S-8, September 1985, U.S. Government Printing Office.

<sup>18</sup> Industrial Market Information System (IMIS) database, Electric Power Research Institute, Palo Alto, CA.

Table 4.5. Metalworking Operations Statistics for Electronic Computing Equipment.

Ferrous foundry	-
Nonferrous foundry (except die casting)	1
Nonferrous die casting	2
Electroplating and other plating	47
Heat treating of metals	22
Automatic screw machine department	20
Machine shop	160
Tool and die shop	61
Plate or structural fabrication	12
Stamping, blanking, and forming of metals	64
Painting, lacquering, and enameling of metals	68
Plastics molding	29
Assembly of product	371
Shipping department, including packing and crating	315

Source: Bureau of the Census, *Selected Metalworking Operations*, Manufacturers Subject Series, 1982.

Table 4.6. Metalworking Operations for Motor Vehicles and Equipment.

Ferrous foundry	22
Nonferrous foundry (except die casting)	7
Nonferrous die casting	29
Forging-presses, hammers, or upsetters	34
Electroplating and other plating	76
Galvanizing and other hot-dip coating	23
Heat treating of metals	149
Automatic screw machine department	109
Machine shop	386
Tool and die shop	265
Foundry pattern shop	13
Plate or structural fabrication	64
Stamping, blanking, and forming of metals	335
Painting, lacquering, and enameling of metals	296
Plastics molding	48
Powder metallurgy	17

Source: Bureau of the Census, *Selected Metalworking Operations*, Manufacturers Subject Series, 1982.



Table 4.7 -INPUT FOR HEAT, POWER AND ELECTRICITY GENERATION AND NET DEMAND FOR ELECTRICITY (BTU in billions)  
 SIC 3714  
 Auto Parts & Accessories

	Row Sum	Electricity Use	Resid	Distil	Nat Gas	LPG	Coal	Other
TOTAL INPUTS	100	38	-- *(A-36)	1	41	1	18 *(A-36)	1 *(A-6)
BOILER FUEL	32	0	--	--	12	0.95 *(A-3)	18 *(A-36)	1 *(A-6)
TOTAL PROCESS	45	26	0	0	19	0	0	0
PROCESS HEATING	21	3	0	0	18	0	0	0
- extrusion								
- forging								
- casting								
- melting		(12%) 0.36 #			(12%) 2.16 #			
- cleaning		(3%) 0.09 #			(6%) 1.08 #			
- drying		(0.6%) 0.018 #			(12%) 2.16 #			
- heat treating		(32%) 0.96 #			(38%) 6.84 #			
- pre-heating		(52%) 1.56 #			(32%) 5.76 #			
PROCESS COOLING/REFRIG								
- cooling								
- refig								
MACHINE DRIVE	20	20	0	0	0	0	0	0
- cut/saw/slit		(11%) 2.2 #						
- turn		(21%) 4.2 #						
- grind		(10%) 2.2 #						
- gear cut		(11%) 2.2 #						
- extrude		(6%) 1.2 #						
- forge, upsetting		(4%) 0.8 #						
- stamp		(6%) 1.2 #						
- form		(4%) 0.8 #						
- weld/join		(6%) 2.2 #						
- paint		(11%) 0.8 #						
- assembly		(11%) 2.2 #						
ELECTROCHEMICAL								
OTHER	2							

\* = inferred from other MECS tables, listed in ( ): otherwise, MECS Table A38.

# = taken from IMIS database.

STEP 2: Estimate the current mix of technologies providing the end use services by fuel type, and the current efficiencies of these technologies.

As mentioned, we will illustrate the calculations in Step 2 by examining one end use -- heat treating. Heat treating is one of the most complex end uses to analyze, because of the vast array of metals and treatments found in industry. Two basic types of heat treating are used -- through heating, where the workpiece is heated to alter the microstructure, soften, harden, or relieve the stress of the entire workpiece. Examples include annealing, normalizing, and tempering. The second is surface and case hardening, where the objective is to alter the properties of the surface of the workpiece only -- examples include carburizing, nitriding, and quench hardening. Since surface and case hardening is likely to be most prevalent heat treatment process found in the auto parts industry, it will be used as the representative heat treatment process.

Currently, surface and case hardening is carried out in a wide variety of furnaces using gas, oil, and electricity. For our purposes, we will restrict our analysis to gas and electric furnaces (96% of the total) of the following types -- gas fired batch (box, flame hardening, pit), gas fired continuous (pusher, salt bath, rotary, fluidized bed), electric resistance batch (vacuum), and continuous electric induction (salt bath and fluidized bed). Table 4.8 gives estimates of the shares of the market currently provided by each technology, along with current estimated gas and electricity efficiencies.<sup>19</sup> (The electrotechnologies' end use efficiencies have been adjusted to reflect the 30% average efficiency of the electricity generation/transmission/distribution system.)

STEP 3: Estimate changes in the end use efficiencies and market shares.

(a) Changes in end use efficiencies

Little major improvement in the efficiencies of the electrotechnologies seems likely, since these systems are already quite efficient, due to the relatively high cost of electricity. Further, most observers expect real electricity prices to fall as the generation side of the industry is deregulated. Deregulation will certainly lead to a decrease in the variance of electricity prices as competition destroys present price differentials at service territory boundaries. It is also likely that the nationwide average price of electricity will also fall, particularly to industrial customers, as expensive reserve margins are reduced with the de-emphasis on the requirement to serve, and industrial customers exercise their market power.

Gas prices, on the other hand, can be expected to increase as it becomes more the fuel of choice by utilities, large industrials, commerce, and households.

The EIA's 1995 *Annual Energy Outlook* projected real natural gas prices in the industrial sector to increase 2.4% per year, ranging from a low of 1.9% in New England to a high of 3% in the Pacific states, while real electricity prices to industrial consumers were projected to increase only 0.3% per year. This should encourage the adoption of gas conserving technologies such as recuperators on case hardening furnaces. It has been estimated that energy efficiency of unrecuperated heat treating furnaces could be increased by 25% by the installation of such devices.<sup>20</sup>

---

<sup>19</sup> Sources: Column (2) - end use efficiency: GRI 87/0001, "Competitive Position of Natural Gas: Ferrous Metal Heat Treating..." prepared for GRI by Hagler, Bailly & Co., October 1987. Column (3) - market shares: GRI 91/0444, "1989 Industrial Process Heating Energy Analysis." prepared for Gas Research Institute by RCG/Hagler Bailly, Inc., May 1991.

<sup>20</sup> A.T. Kearney, Inc., *Energy Efficiency Improvement Target in the Transportation Equipment Industry*, FEA/D-77/256, Chapter IV, July 1976, p. 74.

Table 4.8. Current Surface and Case Hardening Technologies in Use, and Total Consumption.

(1) Technology	(2) End Use Efficiency	(3) % of Total Gas or Electric Fuel Use	(4) Estimated Energy Use in SIC 3714, BTU x 10 <sup>9</sup>
<b>GAS</b>			
Box	26%	32%	2.19
Pit	9%	34%	2.32
Fluidized Bed	38%	3%	0.21
Salt Bath	65%	11%	0.75
Pusher	15%	18%	1.23
Rotary	27%	-	-
Flame Hardening	15%	2%	0.14
		<u>    </u> = 100%	<u>    </u> 6.84
<b>ELECTRIC</b>			
Salt Bath	20% *	31%	0.31
Induction	20% *	65%	0.62
Vacuum	22% *	4%	0.04
Fluidized Bed	20% *	-	-
		<u>    </u> = 100%	<u>    </u> 0.96

\* Electricity efficiencies adjusted to account for losses at the electric generation station.

Sources:

Column (2) - end use efficiency: GRI 87/0001, "Competitive Position of Natural Gas: Ferrous Metal Heat Treating...", prepared for GRI by Hagler, Bailly & Co., October 1987.

Column (3) - market shares: GRI 91/0444, "1989 Industrial Process Heating Energy Analysis," prepared for Gas Research Institute by RCG/Hagler Bailly, Inc., May 1991.

Column (4) - Column (3) entry times total heat treating energy use for each fuel, taken from Table 7.

Since the efficiencies of the box, pit, and pusher furnaces assume no recuperation,<sup>21</sup> installation of recuperators would increase their efficiencies to 32, 11, and 19%, respectively. If these improvements were made, total consumption of energy in heat treating would drop from  $7.78 \times 10^9$  BTU to  $6.65 \times 10^9$  BTU, a drop of 14%. This compares well with an independent estimate<sup>22</sup> of a 16% reduction in gas energy consumption in heat treating expected because of energy conservation.

(b) Changes in technology mix

One source predicted that pollution problems with salt baths would lead to their replacement by fluidized bed furnaces.<sup>23</sup> If this were to take place, then energy use would increase from 0.5 to  $1.7 \times 10^9$  BTU, depending on which type of fluidized bed -- gas or electric -- replaced the salt bath technology. Here we assume gas fired beds replace salt baths. One additional development -- the substitution of rotary for pusher furnaces -- would reduce energy consumption by  $0.36 \times 10^9$  BTU, or about 5%.

Fuel switching -- in this case from gas to electric furnaces -- is a possibility, although the GRI<sup>24</sup> heat treating study sees a near zero net energy impact, as both gas and electric furnaces replace LPG and oil fired ones.

One possible fuel switch -- from flame hardening to induction hardening -- may very well be made because of inductions' short heating cycle and better controllability. While induction heater end use efficiency is in the range of 65%, while flame hardening is only 15%, energy conservation opportunities are small when the 65% is reduced to 20% to reflect losses at the generating station.

Table 9 summarizes the impact of these changes on heat treating energy consumption in SIC 3714. A comparison of Table 9 with Table 7 shows that the expected developments in heat treating efficiencies and technology mixes will result in a 13% decline in heat treating energy use in SIC 3714, from  $7.8 \times 10^9$  BTU to  $6.76 \times 10^9$  BTU.

### Part 3 - Summary

While the methodology described may seem tedious to some and too detailed to others, it is a defensible and reasonable approach to estimating likely changes in energy consumption, if the goal is to break down the changes by end use. One could easily argue with the assumptions that underlie the 13% reduction, but the assumptions are explicit, and easily understood by energy managers, production supervisors, vendors, and the like in industry. Indeed, that is the strength of the approach. While econometric and other statistical approaches have their place, practitioners' desire to understand and challenge the assumptions which underlie energy consumption forecasts are weak to non-existent when the uncertainty has to do with confidence intervals and goodness of fit tests, rather than the fate of salt baths and fluidized bed technologies.

At the time of this writing (June 1995) the data necessary to complete the study for all SICs and all end uses was not yet available. Additional results will be presented as handouts at the August meeting.

---

<sup>21</sup> See GRI 87/0001.

<sup>22</sup> "Factors Affecting Industrial Energy Consumption and Natural Gas Use." GRI 92/0508.2, p. C-37.

<sup>23</sup> GRI 87/0001, p. 169.

<sup>24</sup> GRI 92/0508.2, p. C-37.

Table 4.9. Projected Heat Treating Energy Use.

(1) Technology	(2) Projected End Use Efficiency	(3) Projected % of Total Fuel Use	(4) Projected Energy Use in SIC 3714, BTU x 10 <sup>9</sup>
<b>Gas</b>			
Box	32%	30%	1.78 (a)
Pit	11%	32%	1.90 (b)
Fluidized Bed	38%	28%	1.65 (c)
Salt Bath	65%	-	0 (c)
Pusher	19%	-	0 (d)
Rotary	27%	10%	0.68 (d)
Flame Hardening	15%	-	0 (e)
		<u>-</u> = 100%	<u>6.00 x 10<sup>9</sup> BTU</u>
<b>Electric</b>			
Salt Bath	20% *	-	0 (c)
Induction	20% *	95%	0.72 (e)
Vacuum	22% *	5%	0.04
Fluidized Bed	20% *	-	0
		<u>-</u> = 100%	<u>0.76 x 10<sup>9</sup> BTU</u>

\* Electric end use efficiency adjusted downward to reflect losses at the generating station.

- (a) Current  $2.19 \times 10^9$  BTU use reduced by projected increase in efficiency from 26% to 32%;  $1.78 = (2.19)(26/32)$ .
- (b) Current  $2.32 \times 10^9$  BTU use reduced by projected efficiency gains;  $1.90 = (2.32)(9/11)$ .
- (c) Fluidized bed displaces gas and electric salt bath, resulting in an increase in energy use caused by lowered efficiency; new salt bath load translates into  $(0.31)(20/38) = 0.16$  plus  $(0.75)(65/38) = 1.28$ , or  $1.44 \times 10^9$  BTU additional load, for a total of  $0.21 + 1.44 = 1.65 \times 10^9$  BTU.
- (d) Switch to rotary would reduce energy use to  $(1.23)(15/27) = 0.68$ .
- (e) Induction replacing flame hardening would result in an increase of  $(0.14)(15/20) = 0.10 \times 10^9$  BTU in energy use by induction heaters, for a total of  $0.62 + 0.10 = 0.72$ .

## CHAPTER 5 - WORKING TOGETHER

The previous chapters have discussed many things as if they were separate topics. But each of the chapters are a piece of the overall puzzle that make up the energy field in the industrial manufacturing environment. The primary question at this point is "How do these pieces fit together?". Historically, each of the groups involved, government, utilities, and industry have viewed the other two as disinterested parties that really don't understand current conditions. Government agencies have viewed industry as self-centered companies that are only concerned about bottom-line profits and utilities as monopolistic organizations resisting interference from outsiders. Utilities view industry as companies which want energy at no cost and government agencies as the means of giving industry this energy. Industry views utilities as hoarders of energy constantly demanding higher and higher rates for that energy and government as a useless meddler. These views are archaic and detrimental to the economy as a whole. All three sides need to set individualistic views aside and work together if we are to improve the overall manufacturing efficiency within this country. As Dan Williams was quoted earlier, now is the time for us to act. The three groups need to develop means to work together in a fashion that provides a win-win situation for everyone. Regulation which mandates efficiency levels in industry, utility rates which have industry subsidizing non-related programs, and refusing to implement programs which have no direct impact on production rates are examples of philosophies which need to be changed. There are numerous examples of two or more parties collaborating together to provide winning combinations. Bonneville Power Administration working with the aluminum smelters in the Pacific Northwest have developed an effective aluminum smelter conservation/modernization program. The Department of Energy's EADC centers have been successful at providing audits and recommendations for small to medium sized manufacturers. Utilities such as Niagra-Mohawk, Detroit Edison, Puget Power and Southern California Edison are working with industrials to develop energy conservation and efficiency improvement programs. The examples are there for all to see.

So what really needs to be done? Lets look at each piece of the puzzle and see if an overall picture becomes visible.

First is the government. Programs such as Green Lights and Energy Star Buildings are, in reality, fairly ineffective programs that are a waste of time. They attempt to get industry to commit to unrealistic goals in an unreasonable time frame. In a time when industry is competing for its life with overseas companies which are frequently subsidized by governments, funds and resources are not available to accommodate ineffective and useless programs. Organizations such as DOE's Energy Analysis and Diagnostic Centers, the Washington State Energy Office, and Motor Challenge are effective sources of information and opportunities. There should be no restrictions on company type, size or profitability in order to take advantage of these programs because they have value to everyone. The Energy Policy Act of 1992 was a major achievement. Adding tax incentives to utilities and industries for implementing efficiency improvement programs and allocating funds to those programs authorized by EPAct would be the next step. Nadel and Jordan (1993) recommended a one stop energy center in each state operated by DOE. This idea has merit in that these centers can act as clearinghouses of information. Carrying that concept further, these "one stop shopping" centers should also have a service branch consisting of auditors, engineers and scientists that work in the field to help utilities and industries develop and implement programs. These services do not need to be free. Charging reasonable rates for a valued service is a common practice in industry. Numerous consulting companies continuously make substantial profits even in "failing" economies. What is stopping the government from operating these energy centers as profit centers? The answer is bureaucratic momentum and greedy selfish politics, neither of which have a place in business, and energy is BIG BUSINESS!

What benefits will be gained by government cooperating with industry? By implementing effective programs, making available useful tools, and limiting unnecessary regulations, several things are likely to occur. There will be greater participation by industry to help reach a common goal of reduced dependence on foreign energy sources. By using many of the tools and resources available from government, companies will find it easier to improve their manufacturing processes making them more profitable. As companies become more profitable, they generally, either hire more people or increase the benefits to their employees.

The next group are the Utilities. Utilities should look at the money they spend each year in obtaining generation and commit to purchasing energy in the form of conservation or efficiency improvements at the same rates. This would present another form of competition to the power producers that generate the power sold to utilities and to industry. By reviewing the energy savings potentials from projects implemented at an industrial customer's site, and by offering to purchase that saved energy at rates comparable to those for generating energy, utilities should realize a greater willingness by the industrial community to participate in DSM thereby reducing the amount of energy the utility will need to purchase. The net effect should be to reduce power costs since competition generally forces one to attempt to undercut the competition's prices while maintaining financial liquidity. Power producers which cannot compete will need to find other markets, will need to provide additional services to compensate, develop alternative financing methods, or face going out of business. These are the same things industry faces daily.

Utilities should also be more customer oriented. They should provide services that the various customers can use. Determining which services to provide is a difficult matter. The only solution is to talk with each customer and determine what they can use, what they need, and how these needs can best be met. Examples of the services the utilities can provide are:

- Augmenting the auditing and diagnostics capabilities of the EADCs
- Reviewing engineering designs for opportunities and provide recommendations.
- Act as intermediary or broker in wheeling power to the industrials
- Provide maintenance services for in-plant power distribution systems.

It may be a cliché, but good service does breed loyalty. Utilities will be experiencing considerable competition in obtaining and retaining industrial customers. The costs for providing energy will be weighed against reliability and available services. A utility which provides reliable energy and useful services is likely to retain an industrial customer.

Finally are the industrials. They need to realize that energy is a resource that, for the most part, is not unlimited in nature. Fossil fuels such as coal and natural gas are very limited in nature. As supplies are depleted the costs for these fuels will rise in ever increasing rates. Industrials need to recognize that they are major users of these resources. Those of us in the Pacific Northwest are finding that even hydroelectric power is not an unlimited resource and has impacts on other areas such as native fish habitats. Energy may not be a significant portion of the costs to manufacture, but without it there would be no manufacturing. Industrials need to revise the way energy efficiency improvements are viewed. Instead of restricting payback periods to a few years, utilize true life cycle cost accounting to evaluate whether a project is feasible. Industrials should also invest in energy management, whether by direct employment, through contracting with other industrials or with utilities for the services of an energy manager, or by contracting services from EADC's. Industry has spent billions of dollars to purchase the energy, they should treat energy as another manufacturing commodity that requires resource management. Industry also needs to relax biases towards the energy experts such as the utilities, DOE and the multitude of independent organizations. There is a wealth of information available for the asking, industry just needs to ask.

By working together with government, utilities and other valuable organizations, industry can reduce its energy usage and extend the amount of time that limited resources are available. There are far too many

examples of industry working together with utility companies and government agencies to be presented in this paper. The case study at the end of this chapter is an excellent example of the three groups working together to develop an innovative process and reducing the energy requirements for a very basic system present in virtually all industrial plants.



## CASE STUDY: BOEING'S LONGACRES CUSTOMER SERVICES TRAINING CENTER

### Organizations involved:

The Boeing Company  
King County Department of Metropolitan Services  
Puget Sound Power and Light  
Washington State Energy Office

When The Boeing Company acquired the 215 acre Longacres Park in 1990, a corporate steering committee decided early on that the new Customer Services Training Center (CSTC), the first building to be sited there, be energy efficient and utilize state of the art technologies. With extensive use of computer based training, combined with the full flight simulators, and an operating requirement of 24 hours per day, 365 days per year, it was important to have dependable support systems. This combination lead Boeing to conduct extensive mechanical studies to determine the most cost effective utilities system. These studies involved a joint effort between The Boeing Company, Puget Sound Power and Light (Puget) and King County Department of Metropolitan Services (Metro), that lead to a plan to use the effluent from Metro's Renton Wastewater Treatment Plant as a heat sink for the CSTC chilled water system.

The Washington State Energy Office introduced Metro to the idea of using effluent for heating, a technology commonly used in Nordic countries for district heating. Metro approached Boeing to incorporate the effluent use into the CSTC development. During the same time frame, Puget offered a grant to assess energy efficient designs for the project. Considerable interest was generated by the detailed life-cycle cost analysis of the various options. It was found that the most cost effective, energy efficient system was the use of effluent in a closed-loop heat sink system for chilled water production. A diagram of the system is shown in Figure 5.1.

As the design progressed, a team was formed with representatives from Boeing, Metro and Puget to eliminate roadblocks and overcome any hurdles that may arise during the design and construction phase. Without the concerted efforts of all three organization's representatives, many feel this project would not have been as effective as it turned out.

Boeing identified several potential drawbacks to the effluent system, which centered around reliability, accessibility and maintenance concerns. Reliability was addressed by installing two additional chillers that operate on conventional cooling towers to handle those periods when the effluent system was inoperable due to maintenance or breakdown at the Boeing or Metro facility. These also provide peak load capacity. Accessibility concerns were alleviated by development of a contract arrangement with Metro for them to operate and maintain the Boeing pump system at the Metro facility. The maintenance concerns were that of the "Unknown". Boeing's maintenance personnel had no experience in the operation and maintenance of equipment that uses effluent. This includes equipment such as back-wash strainers and chiller tube brush cleaners, and the procedures required when in contact with the effluent. Boeing and Metro worked together to develop methods and procedures to address these concerns.

In addition to the initial grant for the studies, Puget provided \$1.7 Million toward the project cost. This conservation grant covered the incremental cost increase for the effluent system of the installation of cooling towers. The cost increase was mainly for the installation of the 30" pipeline loop from the Metro facility to the Boeing facility. Since the effluent is in general 15-degrees F cooler than the return condenser water from a typical cooling tower, the effluent chiller can operate more energy efficiently. Also, by purchasing chillers with ultra-efficient heat exchangers operating on R134-A refrigerant, the total electrical savings is approximately \$62,000 per year. Also, by using effluent, potable water is not required, saving an estimated 48 million gallons of water per year. This

equates to a \$114,000 savings per year. Another benefit is a \$15,000 per year savings in cooling tower water treatment chemicals.

“By Boeing, Metro and Puget working as a partnership, this system is so efficient that Boeing will save 20 percent in cooling energy and ultimately use 48 million fewer gallons of water each year. Puget Power calculates that we will save power equivalent to 300 homes annually on the conservation project” said Peter Morton, Boeing’s Director of Customer Training.

**References:**

“*Smart Energy Option: Reusing Wastewater for Cooling Energy*” by Andrew Clapham, Joel Jackman and Mary Lundt.

“*Wash. County, Boeing Launch Water Reuse Energy Conservation Project*”, Clean Water Report, August 16, 1994

“*Using effluent is a cool way to save energy and water at the new training center*” by Steve Copely, Boeing News, August 5, 1994

“*Puget Power, Boeing, Metro Team to save energy*”, Puget Power OUTLET4, August 12, 1994

# Treated Wastewater Cools Boeing Customer Services Training Center

## How it Works

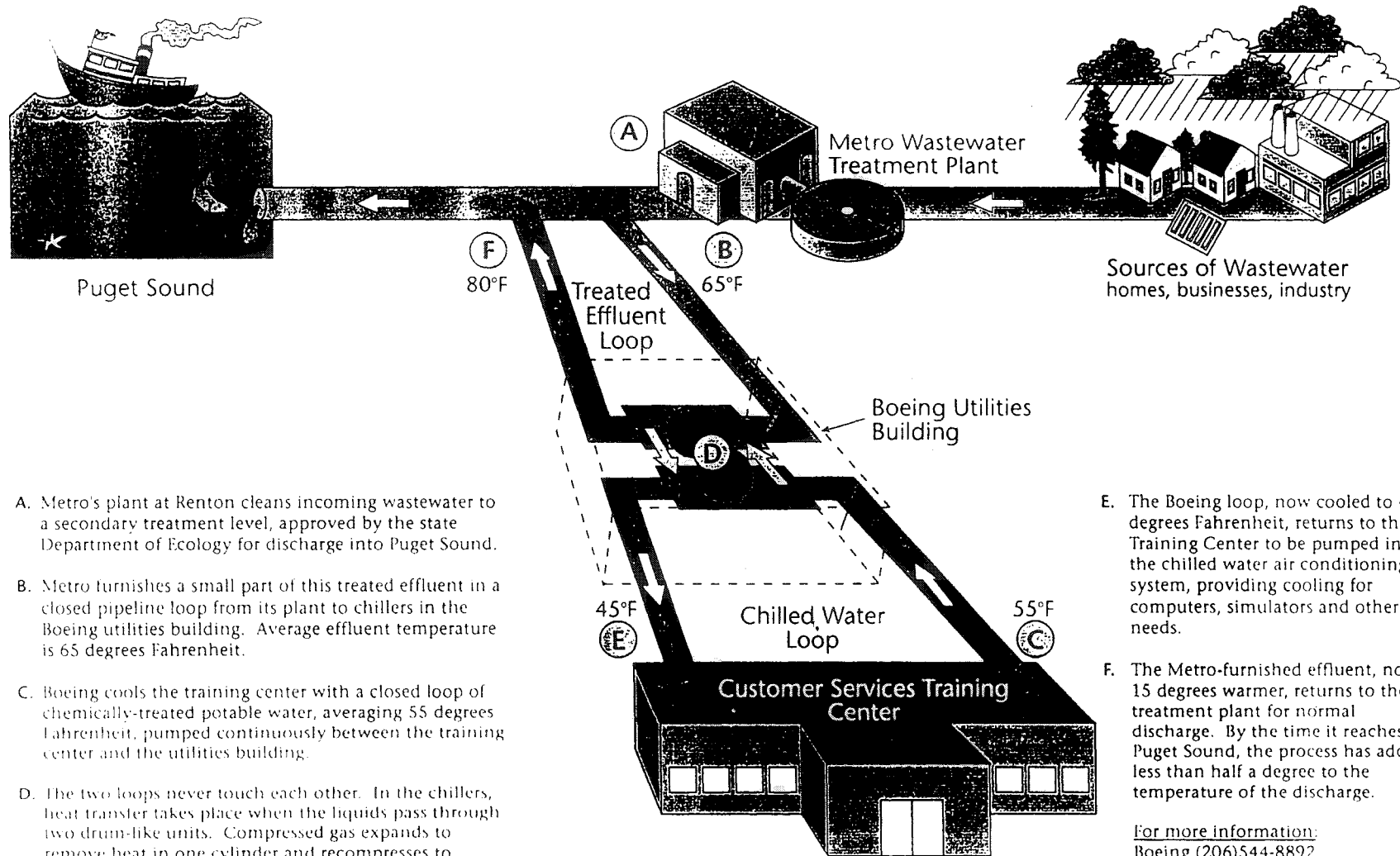

- A. Metro's plant at Renton cleans incoming wastewater to a secondary treatment level, approved by the state Department of Ecology for discharge into Puget Sound.
- B. Metro furnishes a small part of this treated effluent in a closed pipeline loop from its plant to chillers in the Boeing utilities building. Average effluent temperature is 65 degrees Fahrenheit.
- C. Boeing cools the training center with a closed loop of chemically-treated potable water, averaging 55 degrees Fahrenheit, pumped continuously between the training center and the utilities building.
- D. The two loops never touch each other. In the chillers, heat transfer takes place when the liquids pass through two drum-like units. Compressed gas expands to remove heat in one cylinder and recompresses to return to its liquid state in the other—similar to what happens in your household refrigerator.

- E. The Boeing loop, now cooled to 45 degrees Fahrenheit, returns to the Training Center to be pumped into the chilled water air conditioning system, providing cooling for computers, simulators and other needs.
- F. The Metro-furnished effluent, now 15 degrees warmer, returns to the treatment plant for normal discharge. By the time it reaches Puget Sound, the process has added less than half a degree to the temperature of the discharge.

For more information:  
Boeing (206)544-8892  
Metro (206)689-3184

## Bibliography

1. "*Industrial Energy Bulletin*", McGraw-Hill, April 21, 1995
2. "*Manufacturing Consumption of Energy 1991 (MECS)*", DOE/EIA-0512(91), U.S. Department of Energy, Energy Information Administration, Washington, D.C., December 1994
3. "*1990 Survey of Industrial-Sector Demand-Side Management Programs*", EPRI CU-7089, Electric Power Research Institute, Battelle, Mount Pleasant, Pennsylvania, January 1991
4. "*Guide to the Energy Policy Act of 1992*", Williams & Good, The Fairmont Press, Lilburn, Ga., 1994
5. "*The Energy Policy Act of 1992, Public Law 102-486*", assembled by Dan Williams, AC Inc. Press, Washington, D.C.,
6. Annual Energy Review, 1993 DOE/EIA July 1994
7. "*Neoelectrification of Industry in the Information Age*", Schmidt, Sparrow, Vanston and Zarnikau, 1994
8. "*Annual Survey of Manufacturers*", M91 (AS)-1, U.S. Department of Commerce, Bureau of the Census, Washington, D.C., 1991
9. "*Utility/Industrial Partnerships: An Alternative Path for the Design of Industrial DSM Programs*", R.Neal Elliott, American Council for an Energy Efficient Economy, March 1995
10. Energy Analysis and Diagnostic Centers database extract, Industrial Technology and Energy Management Division, University City Science Center, March 1995
11. "*Hardware and Handtools*", Industrial Brief, Vol. 1, No. 39, EPRI 1994
12. "*Successful Steam System Operation Strategies*", W.T. Deacon, 1993
13. "*Reducing Industrial Electricity Costs - an Automotive Case Study*", Price and Ross, The Electricity Journal, July 1989
14. "*Getting in Gear*", Hopkins and Jones, Alliance to Save Energy, 1995
15. "*Study and Evaluation of Energy Efficient Motors*", M.Solis, The Boeing Company, 1993
16. "*How Premium Efficiency Motors Cut Your Electric Costs*", Mecker, EC&M, June 1994
17. "*Washington State Curtailment Plan for Electric Energy*", Chapter 194-22, WAC, Washington State Register, Issue 94-11
18. "*Commitment to Meeting Customer Demands*", The Enthusiast, Harley-Davidson, Inc., Winter 94-95
19. "*Industrial Energy Efficiency*", Office of Technology Assessment, Congress of the United States, August 1993
20. "*Illuminating Industrial Lighting Design Through Energy Efficiency*", Roger Knott, Consulting-Specifying Engineer, March 1993
21. "*Turning Point*", The Motor Challenge, US DOE, DOE/G010094-011, December 1994
22. U.S. Department of Labor, Bureau of Labor Statistics, database extract, April 1995
23. Personal Communication from Maria Tikoff, US EPA, to Fay Weaver, The Boeing Company, regarding Energy Star Buildings Program, March 24, 1995
24. "*Electricity Consumption and the Potential for Electric Energy savings in the Manufacturing Sector*", R.Neal Elliott, American Council for an Energy Efficient Economy, April 1994
25. "*Fabricated Structural Metal Products*", Industry Brief, Vol. 1, No. 31, EPRI 1994
26. "*Impacting the Bottom Line by Purchasing Utilities more effectively*", Jim Nelson, FM Journal, March/April 1994
27. "*1992 survey of Utility Demand-Side Management Programs*", EPRI TR-102193s

28. *"Designing Industrial DSM Programs That Work"*, Nadel and Jordan, American Council for an Energy Efficient Economy, December 1993
29. Green Lights Memorandum of Understanding between US EPA and The Boeing Company, February 1991
30. *"HID Clinic"*, GTE-Sylvania, 1979
31. *"Slashing Your Facility's Utility Bills"*, John Stuebaker, Clemson University, 1993
32. *"IES Lighting Handbook"*, Application Volume, 1981, Kaufman, Illuminating Engineering Society of North America, ISBN 0-87995-008-0
33. *"IEEE Recommended Practice for Energy Conservation and Cost Effective Planning in Industrial Facilities"*, IEEE, April 1985, IEEE Std 739-1984
34. *"HVAC Systems Evaluation"*, Harold Cohen, R.S.Means Company, Inc. 1990
35. *"HVAC Design Criteria, Options, Selection"*, William H. Rowe III, R.S. Means Company, Inc. 1988
  
36. *"1991 ASHRAE Handbook, HVAC Applications"*, I-P Edition, ASHRAE 1991
37. *"Energy Efficiency Improvement Target in the Transportation Equipment Industry"*, A.T. Kearney, Inc., FEA/D-77/256, FEA, Washington, D.C., July 12, 1976
38. *"Energy and Materials Flow in the Fabrication of Iron and Steel Semi-finished Products"*, Argonne National Laboratory, ANL/CNSV-8, Argonne, Ill., August 1979
39. *"Status and Evolution of the U.S. Aluminum Industry: Implications for Natural Gas"*, Arthur D. Little, Inc., GRI 88/0025, Gas Research Institute, Chicago, Ill., 1986
40. *"Potential for Energy Conservation in the Glass Industry"*, Batelle Memorial Institute, PNL-5640/UC-95, Richland, Wash., June 1986
41. *"Additional Sawmill Electricity Energy Study"*, Bonneville Power Administration, Portland, Ore., February 1987
42. *"Industrial Energy Productivity Project, The Pulp and Paper Industry"*, EEA, Inc., DOE/CS/40151-1, Washington, D.C., February 1983
43. *"Electrotechnology Reference Guide, Revision 2"*, Electric Power Research Institute, EPRI TR-101021, Revision 2, Palo Alto, Cal., August 1992
44. *"Factors Affecting Industrial Energy Consumption and Natural Gas Use, Volume II"*, Energy & Environmental Analysis, Inc., GRI 92/0508.2, Gas Research Institute, Chicago, Ill., December 1992
  
45. *"Competitive Position of Natural Gas: Ferrous Metal Heat Treating"*, Hagler, Bailly & Co., GRI 87/0001, Gas Research Institute, Chicago, Ill., October 1987
46. *"1989 Industrial Process Heating Energy Analysis"*, RCG/Hagler Bailly, Inc., GRI 91/0444, Gas Research Institute, Chicago, Ill., May 1991
47. *"Black Liquor Gasification"*, Swedish National Board for Industrial and Technical Development, Stockholm, Sweden, April 1992
48. *"Selected Metalworking Operations: Manufacturers Subject Series"*, U.S. Department of Commerce, Bureau of the Census, Washington, D.C., 1982
49. *"Selected Metalworking Operations: Subject Series"*, MC-82-S-8, U.S. Department of Commerce, Bureau of the Census, Washington, D.C., September 1985
50. *"Annual Energy Outlook 1995"*, DOE/EIA-0383(95), U.S. Department of Energy, Energy Information Administration, Washington, D.C., 1995