

A STATISTICAL BUILDING ENERGY USAGE PREDICTION METHODOLOGY

Jeff S. Haberl and David E. Claridge, Building Systems Program,
Department of Civil, Environmental and Architectural Engineering,
University of Colorado at Boulder.

POTENTIAL FOR ENERGY SAVINGS

Experience with the Rec Center, have been very rewarding. The process of setting up the system, establishing physical and statistical inter-relations and interviewing the maintenance personnel has yielded a 15 percent savings (\$2,500 per month) within the first months of the application. The specific items that lead to the savings events are shown in Table 1.

Similar reductions in energy usage have been reported by others involved in expert systems work (Leah, 1986). In most cases the thorough investigation needed to establish the statistical measurements and assemble the knowledge base uncovered operational inefficiencies, previously overlooked.

THE STATISTICAL PREDICTION NORMALIZERS

Ten parameters were found to significantly effect the Rec Center's consumption. These parameters are grouped according to whether they are environmental parameters (EP), operational parameters (OP) or system parameters (SP). Each of the seven statistical meters (SCONS) are then composed of combinations of parameters that yielded the highest R^2 . The resultant parameters and the SCONS are shown in Figure 2. Figure 3 shows the inter-correlation matrix among the parameters. The seven SCONS are capable of tracking the daily energy consumption to within 9 to 12 percent.

The methodology developed is the result of studies begun in 1980. Current work involves streamlining the process, creating user-friendly I/O, and extending the methodology to additional buildings on campus.

REFERENCES

- Haberl, J., 1986, "An Expert System for the Analysis of Building Energy Consumption," Doctoral Thesis, Department of Civil, Environmental and Architectural Engineering, University of Colorado at Boulder, in progress.
- Haberl, J., Claridge, D., 1985, "Retrofit Energy Studies of a Recreation Center", ASHRAE Transactions. Vol. 91, Part 2.
- Leslie, N., 1986, "Regression Based Process Energy Analysis System", ASHRAE Transactions, V. 92, Part 1.
- Leah, R., 1986, Johnson Controls Corporation, Milwaukee, Wisconsin, personal Communication.

Table I. Recent improvements in energy consuming sub-systems.

- August 29, 1985 - The shower heat-reclaim from the ice rink condensor is fine-tuned, supply temperature reduced 140 to 115F.
- August 29, 1985 - The shower heat-reclaim from the steam condensate heat exchanger is reactivated.
- September 16, 1985 - 20,000 gallon per day leak pool is fixed, normal consumption returns to 700 to 2000 gallons per day.
- November 7, 1985 - A main valve in the ice rink brine circulation loop is found half-closed. Ice setpoint raised from 10 to 17F afterward.
- November 30, 1985 - Gutter heat tapes re-scheduled for periods during snow storms only, previously found to be operational 24 hours-per-day, fall through spring.
- December 3, 1985 - Cross-wiring of locker-room lights corrected. Lites, previously on 24 hours, now off at night.
- December 12, 1985 - 1000 W incandescents in the main gym are shut off at the panel, previously 28 kw of lites in use.
- April 5, 1986 - Ice resurfacing machine changed over to cold water for refill of resurfacing watar. Previously, 2,000 gallons of 140F water consumed each day.

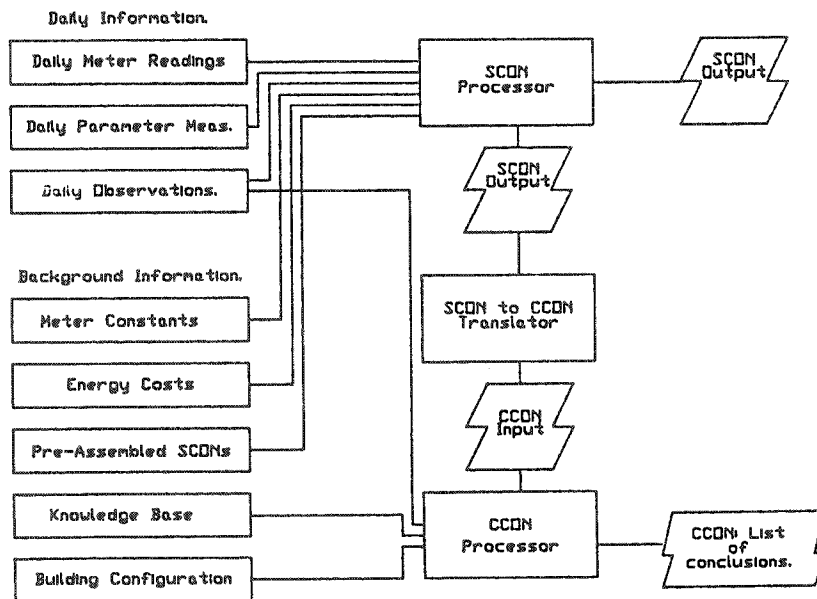

Figure 1. Control Diagram for the BEACON system.

| | SC0N1 Other | Steam SC0N2 Pool | Steam SC0N3 Other | Electric SC0N4 Ice Rink | Compressors SC0N5 Natural Gas | Pool Water SC0N6 | Other Water SC0N7 |
|-----------------------|--|------------------------|-------------------------|-------------------------------|-------------------------------------|---------------------|----------------------|
| EP1 - Average Wind | | | | | | X | |
| EP2 - Outside Air | X | | X | X | | X | X |
| EP3 - Cold Water | X | X | | X | | X | X |
| EP4 - Solar Radiation | SOLAR RADIATION NOT INCLUDED AS OF 6/15/86 | | | | | | |
| DP2 - Oper. Hours | | X | X | | X | X | X |
| DP3 - Zamboni Runtime | | | X | X | X | | X |
| DP8 - Attendance | X | X | X | | X | X | X |
| DP9 - Backwash | | | | | | X | |
| SP1 - Generator | | | | | X | | |
| SP2 - Ice Temp. | | | X | X | | | X |

Figure 2. Statistical Parameters and effected SC0Ns.

| | EP1 - Wind | DP3 - Zamboni | SP1 - Generator | DP8 - Attendance | DP9 - Backwash | SP2 - Ice Temperature | EP2 - Outside Air | EP3 - Cold Water | DP1 - Day-of-Week | DP2 - Oper. Hours | EP4 - Sunlight |
|-------------------|------------|---------------|-----------------|------------------|----------------|-----------------------|-------------------|------------------|-------------------|-------------------|----------------|
| EP1 - Wind | 1.0 | 0.008 | 0.000 | 0.000 | 0.005 | 0.008 | 0.164 | 0.000 | 0.002 | 0.000 | 0.049 |
| DP3 - Zamboni | | 1.0 | 0.001 | 0.177 | 0.001 | 0.015 | 0.097 | 0.209 | 0.000 | 0.148 | 0.032 |
| SP1 - Generator | | | 1.0 | 0.021 | 0.001 | 0.017 | 0.012 | 0.029 | 0.002 | 0.022 | 0.011 |
| DP8 - Attendance | | | | 1.0 | 0.021 | 0.020 | 0.006 | 0.001 | 0.118 | 0.649 | 0.002 |
| DP9 - Backwash | | | | | 1.0 | 0.009 | 0.003 | 0.006 | 0.004 | 0.018 | 0.000 |
| SP2 - Ice Temp. | | | | | | 1.0 | 0.087 | 0.069 | 0.000 | 0.019 | 0.090 |
| EP2 - O/A | | | | | | | 1.0 | 0.354 | 0.000 | 0.004 | 0.187 |
| EP3 - Cold Water | | | | | | | | 1.0 | 0.000 | 0.000 | 0.051 |
| DP1 - Day-of-Week | | | | | | | | | 1.0 | 0.081 | 0.000 |
| DP2 - Oper. Hours | | | | | | | | | | 1.0 | 0.001 |
| EP4 - Sunlight | | | | | | | | | | | 1.0 |

Figure 3. Inter-correlation matrix for the parameters.