



The Market and Technical Potential for Combined Heat and Power in the Commercial/Institutional Sector

Prepared for:

**U.S. Department of Energy
Energy Information Administration
1000 Independence Ave., SW
Washington, DC 20585**

Prepared by:

**ONSITE SYCOM Energy
Corporation
1010 Wisconsin Ave, NW
Suite 340
Washington, DC 20007
202-625-4119**

***January 2000
(Revision 1)***

PREFACE

This report was prepared by ONSITE SYCOM Energy Corporation as an account of work sponsored by the Energy Information Administration. Bruce A. Hedman, Vice President of consulting services at ONSITE SYCOM was the principal investigator for the analysis. ONSITE SYCOM would like to acknowledge Erin E. Boedecker and Steven H. Wade of the Energy Information Administration for their technical guidance and support in the preparation of this report.

Table of Contents

1. EXISTING CHP IN THE COMMERCIAL/INSTITUTIONAL SECTORS.....	2
1.1 METHODOLOGY	2
1.2 PROFILE OF EXISTING COMMERCIAL/INSTITUTIONAL CHP.....	3
1.3 IMPLICATIONS FOR EIA COMMERCIAL SECTOR MODELING.....	8
2. TECHNICAL MARKET POTENTIAL FOR COMMERCIAL/INSTITUTIONAL CHP.....	9
2.1 TECHNICAL APPROACH.....	9
2.2 TARGET CHP APPLICATIONS.....	10
2.3 CHP TECHNICAL MARKET POTENTIAL.....	12
3. CHP TECHNOLOGY CHARACTERIZATION	18
3.1 NEMS CHP TECHNOLOGY CHARACTERIZATION.....	18
3.2 RECOMMENDED CHP TECHNOLOGIES FOR THE COMMERCIAL SECTOR	20
3.3 MICROTURBINES.....	20
3.4 FUEL CELL POWER SYSTEMS.....	23
3.5 RECIPROCATING ENGINES	25
3.6 COMBUSTION TURBINES.....	28
3.7 OPERATING AND MAINTENANCE COSTS.....	32
4. REFERENCES.....	35
APPENDIX A - PROFILE OF EXISTING CHP.....	37
APPENDIX B - PROFILE OF TECHNICAL MARKET POTENTIAL.....	55
APPENDIX C -CHP TECHNOLOGY CHARACTERIZATION	59
1. RECIPROCATING ENGINES	62
2. STEAM TURBINES	68
3. COMBUSTION TURBINES AND COMBINED CYCLES.....	71
4. MICROTURBINES.....	76
5. FUEL CELLS	79
6. SYSTEM ISSUES.....	83

The Market and Technical Potential for Combined Heat and Power in the Commercial/Institutional Sector

ONSITE SYCOM Energy Corporation (OSEC) is assisting the U.S. Department of Energy's Energy Information Administration to determine the potential for cogeneration or combined heat and power (CHP) in the commercial/institutional market. As part of this effort, OSEC has characterized typical technologies used in commercial CHP, analyzed existing CHP capacity in commercial and institutional applications, and developed estimates of additional technical potential for CHP in these markets.

This report is organized into three sections as follows:

1. Profile of Existing Commercial/Institutional CHP
2. Market Potential for Commercial/Institutional CHP
3. CHP Technology Characterization

1. Existing CHP in the Commercial/Institutional Sectors

According to the *Commercial Buildings Energy Consumption Survey, 1995*¹ prepared by EIA, there were 4.6 million commercial buildings in the United States as of 1995. These buildings consumed 5.3 quads of energy, about half of which was in the form of electricity – or about 760 billion kWhs. OSEC analysis shows that there are currently over 980 operating CHP facilities in the commercial/institutional sector producing an estimated 29 billion kWhs of electricity and 0.15 quads of thermal energy. Therefore, CHP meets 3.8% of the total energy needs of the commercial sector as a whole while it is sited in only 2/100th of a percent of the total number of commercial buildings. Both of these penetration rates are much lower than that found in the industrial sector. OSEC conducted a parallel analysis for EIA of industrial sector CHP and found over nine times the CHP penetration as in the commercial sector. The industrial sector is characterized by approximately the same total electricity consumption as the commercial sector, but over five times the demand for fuels for both thermal processes and feedstocks.

The profile of existing CHP was developed to understand the technologies and applications that comprise existing CHP capacity and to provide insight into projections of future market development.

1.1 Methodology

OSEC used the most recent update to the Hagler Bailly *Independent Power Database* (HBI)² to develop a profile of existing cogeneration activity in the commercial sector. OSEC has not found any single database that contains a comprehensive listing of existing CHP and independent power facilities (i.e., coverage of small systems in the HBI database is incomplete). However, OSEC considers the HBI data as the best available and has worked with it extensively to understand its content and to enhance its coverage and value. Since the HBI database is incomplete in the coverage of small systems (<1 MW), the following analysis is a conservative estimate of existing CHP in the commercial and institutional market sectors. The HBI database includes information for each CHP site including technology, fuel use, electrical capacity (MW), ownership and sell-back of power to the grid.

Before conducting the analysis, OSEC performed extensive quality control on the data in HBI. In particular, some prime mover technologies were recategorized and utility sites were assigned to the appropriate business area for the site. This characterization occurred frequently in 3rd party ownership and gas utility ownership of facilities.

Thermal heat capacity, thermal heat utilization, and hours of operation per year are not part of the HBI database. OSEC developed a thermal heat recovery profile for each CHP technology in the database and assigned these values to the appropriate technology type. To derive the total annual use figures discussed in the introduction, OSEC compared typical operating profiles and data on CHP output to the capacity figures in the database. The average CHP system operates 6000 hours/year and produces about 4900 Btu/kWh of useful thermal energy. The thermal heat utilization factor, which is the ratio of thermal

energy from the CHP system that is utilized to the total amount available was not estimated as this figure is part of the EIA modeling assumptions.

1.2 Profile of Existing Commercial/Institutional CHP

This section characterizes the 980 sites and 4,926 MW of identified CHP in the commercial sector according to the following characteristics:

1. Fuel use
2. Type of technology (prime mover)
3. Type of commercial application
4. State
5. Size of CHP system
6. Ownership and Sales

This section provides a tabulation and discussion of these factors. Detailed tables with cross-tabulation of these results are contained in **Appendix A**.

Fuel Type

Figure 1.1 shows the share of operating commercial CHP by fuel type. Natural gas is by far the most common fuel type comprising over 72% of the total. The next most important fuel type is *waste*. Waste includes a variety of fuels but is dominated by landfill gas and biogas from sewage treatment facilities. Coal, oil, wood, and other fuel types make up the remaining 15% of installed CHP capacity.

Figure 1.1. Existing Commercial Sector CHP Capacity by Fuel Type (MW)

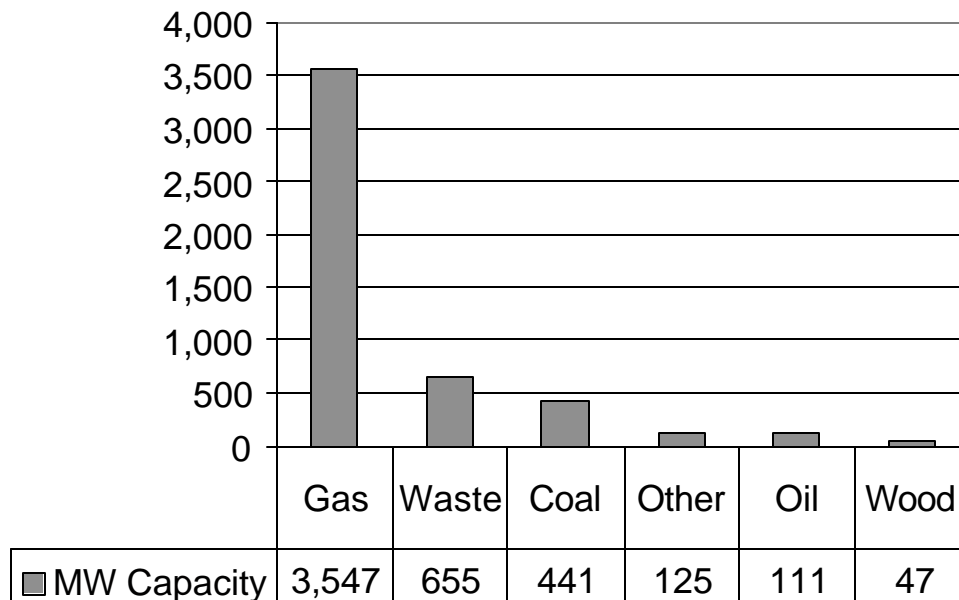

In terms of the number of operating sites, natural gas is the primary fuel in 88% of the 980 sites.

Type of Prime Mover

Table 1.1 characterizes the commercial sector CHP in terms of the prime mover driving the generator. The largest share of capacity (42.8%) comes from combined cycle power plants consisting of a combustion turbine and a heat recovery steam generator (HRSG) that drives a backpressure or extraction steam turbine. These plants are capable of high efficiency and are typically used only in comparatively large installations. Boilers and steam turbines make up 27% of total capacity. Boilers can fire any fuel type, but they are the only type of technology today that can be used to generate power from solid fuels like coal, wood, and certain types of waste. Combustion turbines make up about 19% of installed capacity. Both combined cycle and combustion turbines are technically capable of burning a variety of gaseous or liquid fuels, but, in U.S. CHP applications, they nearly always burn natural gas. Reciprocating engines make up 10% of capacity but represent 79% of the total number of installations. Reciprocating engines are commonly used in smaller installations; the average size for operating engine CHP systems is 0.7 MW. The average size for all operating commercial sector CHP is 5 MW.

Table 1.1. Commercial Sector CHP by Prime Mover in terms of Capacity, Number of Sites, and Average Size

Prime Mover	Capacity MW	Share %	Sites	Share %	Avg. Size MW
Combined Cycle	2,110	42.8%	27	2.8%	78.1
Boiler/Steam	1,341	27.2%	60	6.1%	22.4
Combustion Turbine	933	18.9%	104	10.6%	9.0
Recip. Engine	506	10.3%	770	78.6%	0.7
Other/not specified	36	0.7%	19	1.9%	1.9
Total	4,926	100.0%	980	100.0%	5.0

Type of Commercial/Institutional Applications

The commercial and institutional sectors are comprised of a broad range of activities that include private and government services but not including manufacturing, mining, or agriculture. Commercial applications, typically but not exclusively, are based on energy use in buildings. Unlike the industrial sector that, on balance, reflect an electric load limited environment for CHP, the commercial sector is predominantly thermal load limited. This limitation can occur in two ways; either the thermal load is inadequate or it is highly seasonal, i.e., noncoincident with the electric load – as in the thermal needs for space heating. Another limitation of commercial applications is the more limited hours of operation compared to an industrial process operation. An office building may operate 3,500 hours per year compared to a refinery that is operated continuously, or 8,760 hours per year. High and fairly constant thermal loads and a high number of operating hours per year characterize the commercial applications that are favorable to CHP. CHP

systems are also typically sized to operate on a baseload basis and utilize the electric grid for supplementary and backup power.

Figure 1.2 shows the installed capacity of CHP by commercial application. The top eight applications represent 90% of the commercial sector installed CHP. These top eight sectors are as follows:

1. Colleges and Universities – This is the number one commercial CHP application with 29% of the total installed capacity. Universities resemble district-heating systems for small cities. CHP systems in universities typically serve the power and thermal needs of a multibuilding site.
2. District Energy/Utilities – About 20% of the total is for district energy or utility applications. These systems tend to be large, multimegawatt facilities serving a variety of applications and buildings.
3. Government – Government use represents a broad range of activities and commercial/institutional buildings.
4. Hospitals – Hospitals are large facilities with around-the-clock operation and large, steady thermal and electric requirements. They typically have engineering and operating staff on-site to manage a CHP system.
5. Solid Waste – This is not a necessarily building energy application but reflects landfill or waste to energy projects with some form of heat recovery.
6. Offices – This is one of the largest types of commercial applications in terms of building space.
7. Airports – Nine major airports have CHP systems to serve multiple buildings. These systems are generally in the multi-megawatt size range.
8. Health/Sports Centers – Rounding out the top 90% of commercial applications are health clubs and sports centers. These facilities represent a good match of steady electric and thermal loads.

Figure 1.2. Capacity of Commercial CHP by Type of Commercial Application (MW)

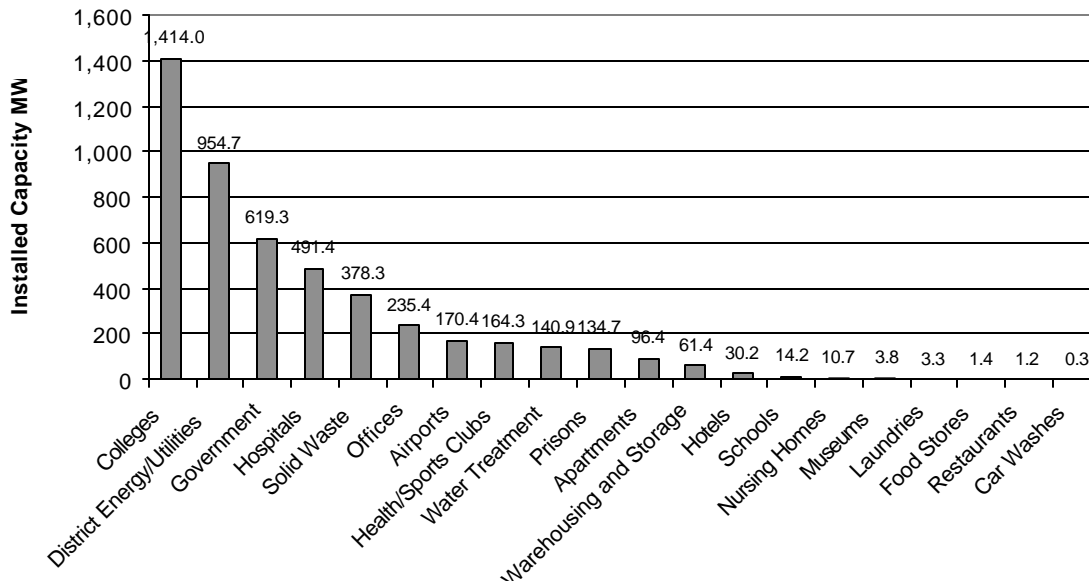

Commercial/Institutional CHP Distribution by State

Commercial CHP is concentrated in the populous industrialized states of the Northeast, Midwest and California and Texas. In addition to large population and economic activity, these states typically have higher energy costs than the rest of the United States. **Figure 1.3** shows the distribution of CHP capacity by state. Nearly half the total installed capacity is in three states – New York, California, and Pennsylvania. Adding in the next five largest states – Texas, Wisconsin, Michigan, New Jersey, and Florida – brings the cumulative share up to 75%.

Figure 1.3 Installed Commercial CHP by State

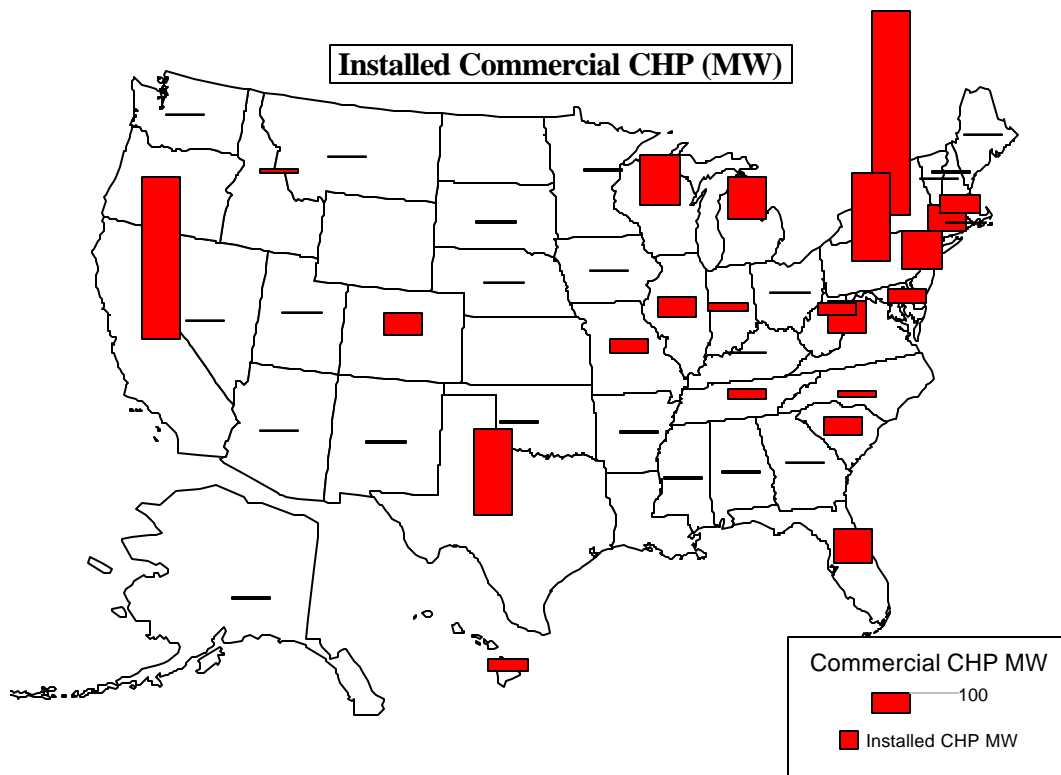

Distribution of CHP Systems by Size

Table 1.2 shows the size breakdown of commercial CHP by prime mover. Over 70% of the existing facilities are under 1 MW. Most of these small systems are powered by reciprocating engines. While the number of sites is dominated by the smaller sized systems, the total capacity impact of these small systems is comparatively small. The majority of the CHP capacity comes from the smaller number of large systems. There are 63 sites with capacities greater than 20 MW – including combustion turbine, combined cycle, and boiler/steam systems. These 63 large sites make up 77% of the existing commercial sector CHP capacity.

Table 1.2. Commercial Sector CHP by Size Range and Prime Mover (Units)

Size Range	Boiler/ Steam	Combined Cycle	Combust. Turbine	Recip. Engine	Other	Total
0 – 999 kW	7		20	662	16	705
1.0 – 4.9 MW	15		42	83		140
5.0 – 9.9 MW	4	3	16	16	1	40
10.0 – 14.9 MW	3		11	7	2	23
15.0 – 19.9 MW	7		2			9
20.0 – 29.9 MW	5	6	5	2		18
30.0 – 49.9 MW	8	5	6			19
50.0 – 74.9 MW	11	4				15
75.0 – 99.9 MW		2	2			4
100 – 199 MW		5				5
200 – 499 MW		2				2
Total	60	27	104	770	19	980

CHP Ownership and Sales

CHP facilities can be owned and operated by the site facility or by a 3rd party. In addition, the facility can either use all of the power onsite or sell all or part of the electrical output to the electric utility or a third party. **Figure 1.4** shows that 3rd parties own 60% of facilities (69% of capacity) and that 25% of facilities (78% of capacity) sell some portion of their power.

Figure 1.4. Ownership and Sales Characteristics of Commercial Sector CHP

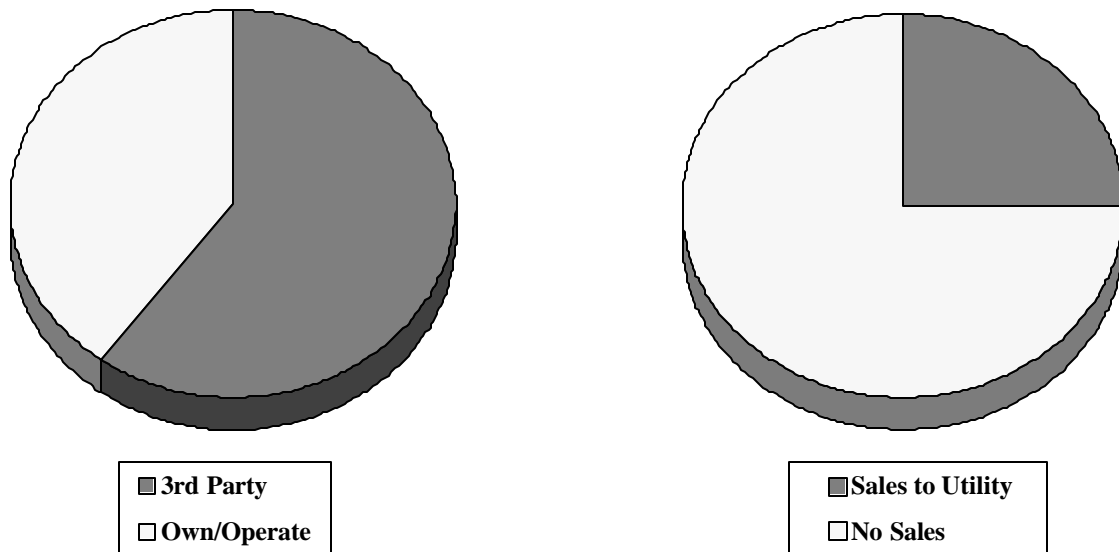

1.3 Implications for EIA Commercial Sector Modeling

The analysis of the existing CHP in the commercial sector leads to some conclusions regarding the scope of the CHP modeling and the technologies selected.

Natural gas is the predominant fuel for commercial CHP systems. Using natural gas-fired technologies as the basis for defining future growth in the sector seems appropriate. It may also be appropriate to do specific analyses of certain commercial activities such as solid waste and water treatment to identify specific opportunities for waste fueled systems.

The existing results show that the CHP in the commercial sector derived from 63 large (>20 MW) installations makes up 3/4th of the total capacity. These systems use large-scale technology such as combustion turbines and combined cycle systems that are also common in industrial CHP. These systems are not well reflected in the current EIA CHP technology profiles.

The commercial sector offers a promise of a large number of potential applications in small size ranges suitable for microturbines, fuel cells, and small gas engines. To date, penetration in this market has been extremely limited. A number of small engine CHP packagers have entered and exited the market in the last 15 years, as market conditions proved too difficult for many. Today, there is a new generation of technologies and developers hoping to reach the large number of customers in this small-end market. These developers envision sales in the tens, even hundreds, of thousands of units. It is important for the EIA CHP modeling framework to adequately represent the technologies in this area and reflect the real costs of the early entry market as well as the opportunity for technology improvement.

2. Technical Market Potential for Commercial/Institutional CHP

This section summarizes the analysis of CHP technical potential in the commercial/institutional sector of the U.S. economy. This analysis is based on existing facilities and estimates of their current power and thermal consumption. The derived potential is a snapshot of the technical potential for CHP at these facilities at the end of 1999 and does not include an analysis of sector growth over the time period of the EIA forecast. The technical market potential is an estimation of market size constrained only by technological limits—the ability of CHP technologies to fit existing customer energy needs. No consideration of economics is included in the analysis.

2.1 Technical Approach

The following approach was used to estimate the market potential for CHP in the commercial/institutional sectors:

- *Identify applications where CHP provides a reasonable fit to the electric and thermal needs of the user.* Target applications were identified based on reviewing the electric and thermal energy consumption data for various building types from the DOE EIA 1995 Commercial Buildings Energy Consumption Survey (CBECS) and various commercial market summaries developed by GRI and the American Gas Association.^{3,4,5,6,7} Existing CHP installations in the commercial/institutional sectors were also reviewed to understand the required profile for CHP applications and to identify target applications.
- *Quantify the number and size distribution of target applications.* Once applications that could technically support CHP were identified, the iMarket, Inc. *MarketPlace Database* was utilized to identify potential CHP sites by SIC code.⁸ The *MarketPlace Database* is based on the Dun and Bradstreet financial listings and includes information on economic activity (8 digit SIC), location (metropolitan area, county, electric utility service area, state) and size (employees) for commercial, institutional and industrial facilities. In addition, for select SICs limited energy consumption information (electric and gas consumption, electric and gas expenditures) is provided based on data from Wharton Econometric Forecasting (WEFA). The *MarketPlace Database* was used to identify the number of facilities in target CHP applications and to group them into size categories based on average electric demand in kW.
- *Estimate CHP potential in terms of MW capacity.* Total CHP potential was then derived for each target application based on the number of target facilities in each size category. It was assumed that the CHP system would be sized to meet the average site electric demand for the target applications unless thermal loads limited electric capacity.

2.2 Target CHP Applications

The simplest integration of CHP into the commercial and institutional sectors is in applications that meet the following criteria:

- relatively coincident electric and thermal loads
- thermal energy loads in the form of steam or hot water
- electric demand to thermal demand (steam and hot water) ratios in the 0.5 to 2.5 range (this matches available technologies as identified in Section 2), and
- moderate to high operating hours (>4000 hours per year)

A review of energy consumption intensity data for commercial/institutional building types as presented in the 1995 CBECS is shown in **Table 2.1**. Electric intensities are taken directly from the CBECS data for each building type. Space heating and water heating data in CBECS reflect fuel energy inputs for each category. These fuel inputs were modified to reflect building thermal demands using a conversion efficiency of 85%.

Table 2.1 Energy Intensities for Commercial/Institutional Buildings¹

Application	Electricity Use (Tbtu)	Electric Intensity (kWh/sq ft)	Space Heating (1000 Btu/sq ft)	Water Heating (1000 Btu/sq ft)	E/T Ratio (Total)	E/T Ratio (Water Htg)
Education	221	8.4	32.8	17.4	0.67	1.94
Health care	211	26.5	55.2	63	0.90	1.69
Lodging	187	15.2	22.7	51.4	0.82	1.19
Food Service	166	36	30.9	27.5	2.47	5.25
Food Sales	119	54.1	27.5	9.1	5.93	23.86
Office	676	18.9	24.3	8.7	2.30	8.72
Mercantile/Service	508	11.8	30.6	5.1	1.33	9.29
Public Assembly	170	12.7	53.6	17.5	0.72	2.91
Public Order	49	11.3	27.8	23.4	0.89	1.94
Religious Worship	33	3.5	23.7	3.2	0.52	4.35
Warehouse/Storage	176	6.4	15.7	2	1.46	12.92
Other	75	22.0	59.6	15.3	1.18	5.77

As described in Section 3, the outputs from available CHP technologies have electric to thermal ratios in the range of 0.5 to 2.5. Thermal energy output is usually in the form of steam or hot water. Thermal loads most amenable to CHP systems in commercial/institutional buildings are space heating and hot water requirements. The simplest thermal load to supply is hot water. Retrofits to the existing hot water supply

are relatively straightforward, and the hot water load tends to be less seasonally dependent than space heating, and therefore, more coincident to the electric load in the building. Meeting space heating needs with CHP can be more complicated. Space heating is seasonal by nature, and is supplied by various methods in the commercial/institutional sector, centralized hot water or steam being only one. For these reasons, primary targets for CHP in the commercial/institutional sectors are those building types with electric to hot water demand ratios consistent with CHP technologies: Education, Health Care, Lodging, and certain Public Order and Public Assembly applications. Office Buildings, and certain Warehousing and Mercantile/Service applications can be target applications for CHP if space heating needs can be incorporated.

One difficulty with estimating market potential based on the classifications listed in **Table 2.1** is that the classifications are quite broad in nature. As an example, health care includes not only hospitals that are ideal candidates for CHP because of their extended operating hours and electric and thermal profiles, but also clinics and outpatient services that have limited operating hours and limited thermal needs. Other categories such as office buildings that in total do not appear to be good candidates have subcategories such as large (>50,000 sq feet), 18 hour a day office buildings where the energy needs and operating characteristics support economic CHP. **Table 2.2** presents the specific building types most amenable to existing CHP technologies based on an analysis of existing CHP in the commercial/institutional sectors and a review of available building energy characteristics.

Table 2.2 CHP Target Applications - Existing Technology

Application	CHP System Size	Thermal Demand
Hotels/Motels	100 kW - 1+ MW	Domestic hot water, space heating, pools
Nursing Homes	100 - 500 kW	Domestic hot water, space heating, laundry
Hospitals	300 kW - 5+ MW	Domestic hot water, space heating, laundry
Schools	50 - 500 kW	Domestic hot water, space heating, pools
Colleges/Universities	300 kW - 30 MW	Centralized space heating, domestic hot water
Commercial Laundries	100 - 800 kW	Hot water
Car Washes	100 - 500 kW	Hot water
Health Clubs/Spas	50 - 500 kW	Domestic hot water, space heating, pools
Country/Golf Clubs	100 kW - 1MW	Domestic hot water, space heating, pools
Museums	100 kW - 1+ MW	Space heating, domestic hot water
Correctional Facilities	300 kW - 5 MW	Domestic hot water, space heating
Water Treatment/Sanitary	100 kW - 1 MW	Process heating
Large Office Buildings*	250 kW - 1+ MW	Domestic hot water, space heating
* (>100,000 sq ft)		

Technology development efforts targeted at heat activated cooling/refrigeration and thermally regenerated desiccants could expand the application of CHP by increasing the base thermal energy loads in certain building types. Use of CHP thermal output for absorption cooling and/or desiccant dehumidification could increase the size and improve the economics of CHP systems in existing CHP markets such as schools, lodging, nursing homes and hospitals. Use of these advanced technologies in applications such as restaurants, supermarkets and refrigerated warehouses provides a base thermal load that opens these applications to CHP. **Table 2.3** includes potential CHP target applications that are currently marginal because of inadequate thermal loads but that would be future target applications based on the use of these advanced technologies.

Table 2.3 CHP Target Applications - Advanced Technology

Application	CHP System Size	Thermal Demand
Extended Service Restaurants	50 - 300 kW	Domestic hot water, absorption cooling, desiccants
Supermarkets	100 - 500 kW	Desiccants, domestic hot water, space heating
Refrigerated Warehouses	300 kW - 5 MW	Desiccants, domestic hot water
Medium Office Buildings*	100 - 500 kW	Absorption cooling, space heating, desiccants
* (25,000-100,000 sq ft)		

2.3 CHP Technical Market Potential

As described earlier, the iMarket, Inc. *MarketPlace Database* was utilized to identify potential CHP sites by building type (SIC) for the target applications included in **Tables 2.2** and **2.3**. The *MarketPlace Database* is based on the Dun and Bradstreet financial listings and includes information on economic activity (8 digit SIC), location (metropolitan area, county, electric utility service area, state) and size (employees) for commercial, institutional and industrial facilities. In addition, for select SICs limited energy consumption information (electric and gas consumption, electric and gas expenditures) is provided based on data from Wharton Econometric Forecasting (WEFA). The *MarketPlace Database* was used to identify the number of existing facilities in target CHP applications and to group them into size categories based on average electric demand in kW. Office buildings represent the one exception to this approach. The *MarketPlace Database* includes information on individual tenants within an office building, but not on the building as a whole. The number of office building sites amenable to CHP was derived from CBECS data on office buildings with average electric demand of 100 kW or greater. These 73,000 office building represent the population of medium and large office buildings as described in **Tables 2.2** and **2.3**.

Table 2.4 lists the number of sites for the target applications in four categories based on average electric demand: 100 to 500 kW; 500 kW to 1 MW; 1 to 5 MW; and greater than 5 MW. Target CHP applications include those building types listed in **Tables 2.2** and **2.3**. As mentioned above, the Office Building category includes both medium and large office buildings (>25,000 sq ft). Restaurants includes full service restaurants only; fast food restaurants are not included due to their inadequate thermal loads.

Table 2.4 Target CHP Applications - Number of Establishments as a Function of Average Site Electric Demand

Application	Total Establishments	Establishments (100 - 500 kW)	Establishments (500 - 1000 kW)	Establishments (1 - 5 MW)	Establishments (> 5 MW)
Hotels/Motels	66,400	12,010	895	540	220
Nursing Homes	19,200	4,610	4,050	1,570	25
Hospitals	16,400	2,945	1,290	2,110	215
Schools	123,890	32,400	9,690	390	0
Colleges/Universities	4,090	1,005	580	680	205
Commercial Laundries	7,275	830	400	10	0
Car Washes	20,630	1,150	40	0	0
Health Clubs/Spas	12,610	3,020	4,060	15	0
Golf Clubs	14,040	3,800	820	205	30
Museums	9,090	330	290	50	0
Correctional Facilities	3,950	1,190	740	610	45
Water Treatment/Sanitary	8,770	2,055	490	65	0
Extended Service Restaurants	271,000	25,475	495	330	0
Supermarkets	148,000	16,300	1,160	140	0
Refrigerated Warehouses	<u>1,460</u>	<u>595</u>	<u>640</u>	<u>75</u>	<u>5</u>
Total	726,805	107,715	25,640	6,790	745
Office Buildings	<u>705,000</u>	<u>57,000</u>	<u>12,000</u>	<u>2,900</u>	<u>290</u>
Total	1,431,805	164,715	37,640	9,690	1,035

The technical potential for CHP in terms of MW capacity was estimated assuming that the CHP systems would be sized to meet the average electric demand for most applications. For the majority of the target markets there is a reasonable match between electric to thermal ratios of the application and the power to heat output of existing CHP technologies. Sizing to meet average electric demand supplies thermal needs for these applications and maximizes the energy efficiency of CHP deployment. It should be noted that the existing CHP capacity described in Section 1 includes a number of large installations that are sized to sell significant amounts of excess power to the grid. The estimate of technical potential in this study assumes all power will be used on-site. A mean system size was calculated for each size category assuming a log normal distribution (220 kW for 100 to 500 kW; 700 kW for 500 to 1000 kW; 2.5 MW for 1 to 5 MW; and 9.5 MW for > 5 MW) and applied to the number of establishments contained in

Table 2.4. The exceptions to this methodology are Office Buildings, Restaurants and Supermarkets. Thermal loads in these applications are generally inadequate to support CHP systems sized to the average electric demand based on current CHP technologies. MW capacities for these applications were reduced using factors that better reflect the electric to thermal ratio of these building types: 0.6 for Office Buildings, 0.5 for restaurants, and 0.25 for supermarkets. Based on this methodology, OSEC estimates that the technical potential for CHP systems in existing commercial/institutional buildings approaches 77,300 MW electric capacity. **Table 2.5** presents estimated market potential in terms of MW capacity by specific target application and size category.

Table 2.5 *CHP Technical Potential in the Commercial/Institutional Sectors - MW Capacity*

Application	MW Capacity (100 - 500 kW)	MW Capacity (500 - 1000 kW)	MW Capacity (1 - 5 MW)	MW Capacity (> 5 MW)	MW Capacity Total
Hotels/Motels	2,642	627	1,353	2,081	6,703
Nursing Homes	1,014	2,837	3,923	219	7,993
Hospitals	647	904	5,275	2,052	8,878
Schools	7,130	6,781	973	0	14,884
Colleges/Universities	221	407	1,693	1,929	4,250
Commercial Laundries	183	279	23	0	485
Car Washes	253	28	0	0	281
Health Clubs/Spas	665	2,839	48	0	3,552
Golf Clubs	836	574	513	285	2,208
Museums	73	202	123	0	398
Correctional Facilities	261	517	1,515	428	2,721
Water Treatment/Sanitary	452	342	155	0	949
Extended Service Restaurants	2,802	173	415	0	3,390
Supermarkets	897	203	84	0	1,184
Refrigerated Warehouses	131	448	183	30	792
Office Buildings	7,532	5,055	4,362	1,665	18,614
Total	25,739	22,216	20,638	8,689	77,281

Table 2.6 compares the CHP market potential for each target application and the existing CHP capacity as described in Section 1. The technical potential as calculated is based on existing commercial/institutional facilities. Subtracting the existing CHP capacity from each target application should result in the remaining technical potential left to be developed in that application based on the existing population of facilities. There are, however, several difficulties in this approach: 1) the application categories of existing CHP do not match the target application classifications exactly. Two categories included in "Other" under "Installed CHP" in **Table 2.6**, Government and District Heating, represent over 1500 MW of installed CHP capacity. These categories are not included as distinct target applications in this analysis. It is likely, however, that many of the building types most likely served by CHP systems in these two categories (offices, hospitals, etc) are included as individual applications in this analysis; 2) certain types of

existing CHP included in "Other" -- Airports and Solid Waste -- representing approximately 550 MW were not included in the current market analysis. Despite these shortcomings, the comparison is useful in revealing the low level of penetration of CHP into most commercial/institutional applications.

Table 2.6 Comparison of CHP Potential and Existing CHP Capacity

Application	Total Potential (MW)	Installed CHP (MW)	Remaining Potential (MW)
Hotels/Motels	6,703	30	6,673
Nursing Homes	7,993	11	7,982
Hospitals	8,878	491	8,387
Schools	14,884	14	14,870
Colleges/Universities	4,250	1,414	2,836
Commercial Laundries	485	3	482
Car Washes	281	0	281
Health Clubs/Spas	3,552	164	3,388
Golf Clubs	2,208	0	2,208
Museums	398	4	394
Correctional Facilities	2,721	135	2,586
Water Treatment/Sanitary	949	141	808
Extended Service Restaurants	3,390	1	3,389
Supermarkets	1,184	1	1,183
Refrigerated Warehouses	792	0	792
Office Buildings	18,614	235	18,379
Other	N/A	2,282	N/A
Total	77,282	4,926	74,638

Figure 2.1 illustrates the 77,282 MW of CHP potential on a state basis. Fifty percent of the total commercial/institutional CHP potential identified in this analysis is located in nine states: California, Florida, Illinois, Michigan, New Jersey, New York, Ohio, Pennsylvania, and Texas. Appendix B includes detailed state tables.

Figure 2.1 Commercial/Institutional CHP Potential by State

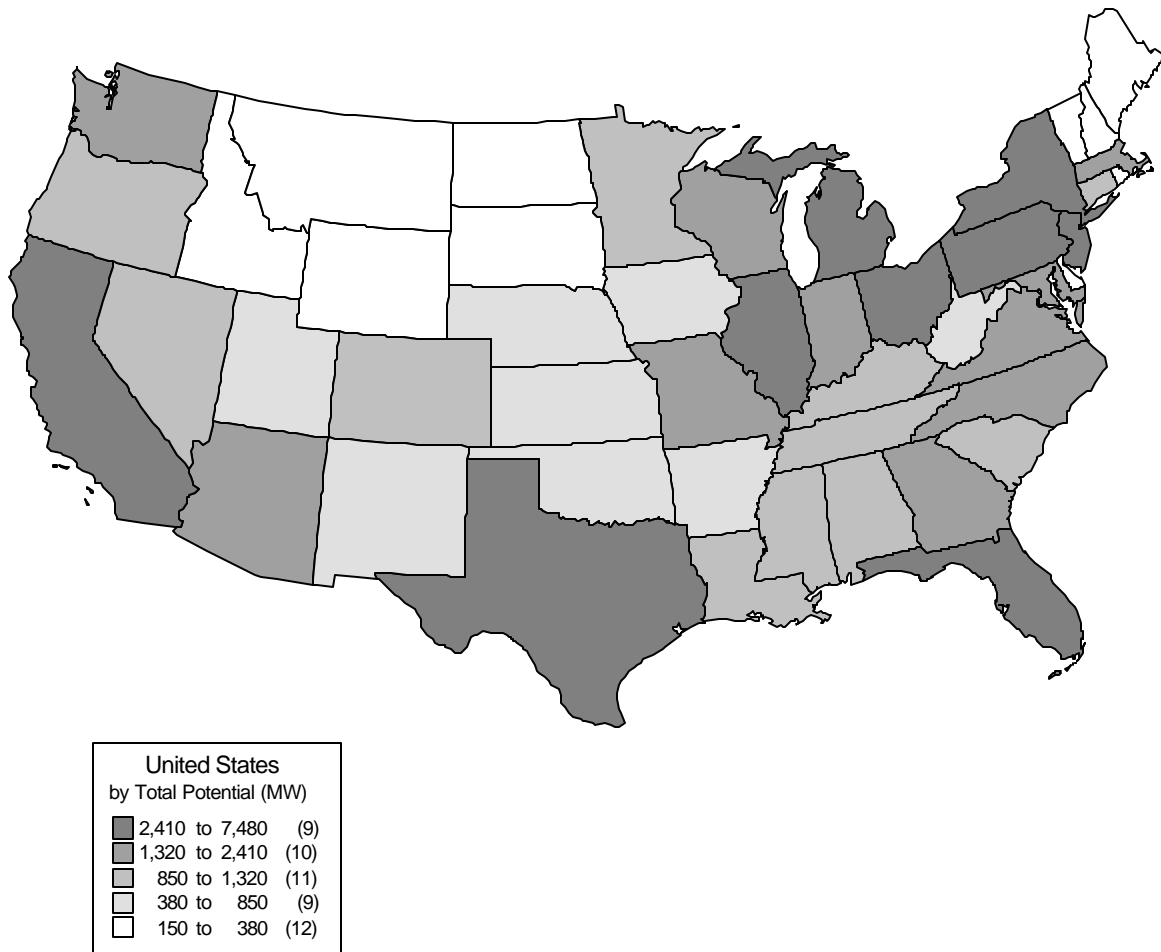

Major conclusions from review of the analysis results include:

- **Significant CHP potential exists at commercial/institutional facilities** - The total technical potential for the commercial/institutional sectors of approximately 75,000 MW electric capacity is on the same order of the remaining technical potential in the industrial sector (88,000 MW)
- **Market penetration to-date is extremely low in the commercial/institutional sectors** - Except for colleges and universities, market penetration of CHP into commercial/institutional applications is minimal.

- **The bulk of existing CHP capacity is in larger systems** - CHP systems of 20 MW or greater represent 63% of existing CHP capacity in the commercial/institutional market.
- **The majority of the technical potential is in small sizes** - 62% of the technical market potential is in system sizes less than 1 MW.
- **Potential CHP sites represent a small fraction of commercial/institutional buildings** - Based on existing technology, only about 5% of the 4.6 million existing commercial buildings in the United States technically meet the criteria for CHP (average electric demand > 100 kW and adequate thermal loads in the form of hot water or steam)
- **The technical market for CHP could be expanded in the commercial/institutional sectors with advanced technologies that utilize thermal energy for non-traditional applications** - CHP potential is limited in commercial/institutional applications due to the lack of adequate thermal energy needs in many building types. Advanced technologies such as heat-activated cooling and thermally regenerated desiccants can expand the economic applications of CHP by providing a base thermal load in building types that do not currently have adequate thermal needs. Cost effective CHP systems in smaller sizes (below 100 kW) would also expand the potential market and increase application of CHP.

3. CHP Technology Characterization

This section provides a discussion of CHP technology appropriate for the commercial/institutional sector and a recommended technology cost and performance dataset for use in the EIA commercial sector NEMS modeling.

3.1 NEMS CHP Technology Characterization

The National Energy Modeling System (NEMS) is a computer-based, energy-economy modeling system of U.S. energy markets for the mid-term period through 2020. NEMS was designed and implemented by the Energy Information Administration (EIA) of the U.S. Department of Energy (DOE). NEMS projects the production, imports, conversion, consumption, and prices of energy, subject to assumptions on macroeconomic and financial factors, world energy markets, resource availability and costs, behavioral and technological choice criteria, cost and performance characteristics of energy technologies, and demographics.

A key feature of NEMS is the representation of technology and technology improvement over time. Five of the sectors--residential, commercial, transportation, electricity generation, and refining--include explicit treatment of individual technologies and their characteristics, such as initial cost, operating cost, date of availability, efficiency, and other characteristics specific to the sector.

This section provides a review and update of combined heat and power (CHP) technology choices for the commercial sector. Of the total existing CHP capacity in the U.S. today, only a little more than 11% occurs within the commercial sector. Even though the commercial sector is about 3/4th as large as the industrial sector in terms of electricity demand, the existing application of CHP is nine times larger in the industrial sector. There are viable CHP opportunities in the commercial sector, but technology and application matching in the commercial sector is more difficult:

- On average, commercial sites are much smaller than industrial sites. Technologies for smaller applications have been more expensive and less efficient than larger CHP.
- Commercial establishments generally operate fewer hours per year and have lower load factors, providing fewer hours of operation per year in which to payback their higher first costs.
- Unlike the majority of industrial projects that can absorb the entire thermal output of a CHP system onsite, many commercial sites have either an inadequate thermal load or a highly seasonal load such as space heating. The best overall efficiency and economics come from a steady thermal load. These loads are concentrated in relatively few types of commercial applications.

Two key changes in the economic system are occurring that could make CHP more important economically and environmentally – the restructuring of the electric power

industry may provide an enhanced economic driver and efforts to comply with the Kyoto Protocol on global warming may provide an environmental driver for energy efficiency options such as CHP. In addition, there is a renewed interest in small scale power technologies and a number of emerging technologies that promise to decrease first costs, increase efficiencies, reduce maintenance, and lower environmental impact. It is critical, therefore, that NEMS have up-to-date and accurate information on CHP technology cost and performance.

The current commercial technology set used in NEMS is shown in **Table 3.1**.

Table 3.1. Existing CHP Cost and Performance Parameters Used in the Commercial Cogeneration Module of NEMS

Technology	Size kW	Efficiency (HHV)		Heat Recovery. Eff.*	Maint. Cost \$/kWyr	Life Years	Current Capital Cost \$/kW		2020 Capital Cost \$/kW	
		Current	2020				Install.	Equip.	Install.	Equip.
Solar PV	10	11%	20%	0%	10	30	\$500	\$7,370	\$275	\$2,151
Fuel Cell	200	40%	40%	75%	15	20	\$125	\$4,000	\$125	\$1,600
Gas Engine	200	35%	35%	60%	15	20	\$125	\$775	\$125	\$775
Conv Coal	200	30%	30%	45%	15	20	N/A	N/A	N/A	N/A
Conv Oil	200	33%	33%	0%	15	20	\$125	\$375	\$125	\$375
Conv MSW	200	24%	24%	45%	15	20	N/A.	N/A.	N/A.	N/A.
Gas Turbine	200	29%	29%	60%	15	20	\$125	\$775	\$125	\$775
Microturbine	100	27%	27%	60%	15	20	\$125	\$775	\$125	\$575
Hydro	200	29%	29%	N/A.	15	20	N/A.	N/A.	N/A.	N/A.
Wood	200	24%	24%	45%	15	20	N/A.	N/A.	N/A.	N/A.

* Heat Recovery Efficiency defined as the ratio of usable thermal energy to the difference between the energy content of the fuel input and the power produced

The database includes all CHP technology types in use in the commercial sector today, with the exception of certain combined cycle installations in use in very large installations. The relative level of cost and efficiencies for the technologies seem reasonable, though not necessarily for the 200 kW size outlined. For example:

- Combustion turbines (CTs) tend to be at least an order of magnitude larger than the 200 kW unit currently in the model (most commercial installations of CTs are in the 1-50 MW size range with a few much larger installations).
- There are a larger number of reciprocating engine installations in the 200 kW size and below, but the cost and performance in the current model seem appropriate for a much larger engine installation.
- There is no projected improvement in efficiency for any technology other than solar PV over the 20-year forecasting period, and only PV and fuel cells show a capital cost reduction. Engine and turbine technologies have been improving continuously over the last twenty years and they will continue to do so. Emerging technologies such as microturbines and fuel cells will also show improvement.

3.2 Recommended Prototype CHP Technologies for the Commercial Sector

The existing commercial CHP market breakdown presented in detail in *Section 1* of this report provided the basis for defining a set of prototype CHP technologies that covers the range of applications found in the market today. In addition, emerging fuel-based technologies such as fuel cells and microturbines are in or are about to enter a phase of early market entry. The developers of these technologies envision significant market penetration occurring over the 20-year forecast period.

Table 3.2 shows the CHP technology types proposed as the basis for considering future market penetration. The list focuses on direct fuel fired systems. Boilers feeding steam turbines are not considered nor are non-fuel fired technologies such as PV. While boiler systems represent about one-quarter of existing commercial CHP systems, the majority of future market development will more likely occur with direct-fired systems. The analysis did not consider PV or other non-fuel systems that may achieve some level of market penetration in the next 20 years.

Table 3.2. Commercial CHP Prototype Technologies

Technology	Size kW	Comments
Microturbine	100	Sizes expected to range from 30-300 kW
Fuel Cell	200	Smaller and larger sizes possible; early entry specifications based on current PAFC, end point based on 2 nd and 3 rd generation technologies
Reciprocating Engine	100	Expected to compete in the 30-300 kW size range
Reciprocating Engine	800	Representing 500-1,500 kW, currently the most competitive size range for recip engines
Reciprocating Engine	3,000	Engines compete with combustion turbines (CTs) up to 10-15 MW per site often in installations of multiple engines
Combustion Turbine	1,000	Not currently a strong market area due to competition with recip engines, technology improvements may enhance future competition
Combustion Turbine	5,000	First tier of the CT competitive range where CT systems begin to emerge as the strongest competitor
Combustion Turbine	10,000	Second tier of CT competitive range; only 12.5% of commercial CT sites-CHP systems are larger than 15 MW but these larger sites make up 60% of total simple cycle CT MW capacity (12% of total CHP capacity)

The following sections present cost and performance estimates for CHP systems using the above technologies. Estimates are provided for a base case utilizing current commercial or about to be commercial technology and for an advanced case that reflects improvements in cost and performance through the year 2020. The improvements are primarily evolutionary in nature, and can be introduced into the NEMs analysis by a

straight line interpolation of the timing of expected performance improvements. The one exception would be in the cost reduction of microturbine systems. Early market success could generate sufficient volumes to accelerate the expected cost reductions in equipment and installation.

3.3 Microturbines

Microturbines are very small combustion turbines with outputs of 30 kW to 200 kW. Several companies are developing systems with targeted product rollout within 1-3 years. Microturbine technology has evolved from automotive and truck turbochargers, auxiliary power units for airplanes or tanks, and small jet engines used for pilotless military aircraft. Recent development of these microturbines has been focused on this technology as the prime mover for hybrid electric vehicles and as a stationary power source for the distributed generation market. In most configurations, the turbine shaft spinning at up to 100,000 rpm drives a high-speed generator. The high frequency output is first rectified and then converted to 60 Hz (for the U.S. market). Advances in this power-electronics technology that support PV and fuel cell technologies are also making microturbine systems economically feasible. The systems are capable of producing power at around 25-30% efficiency by employing a recuperator that transfers heat energy from the exhaust stream back into the incoming air stream. The systems are air-cooled and some even use air bearings, thereby eliminating both water and oil systems. Low emission combustion systems are being demonstrated that provide emissions performance comparable to larger CTs. Microturbines are appropriately sized for commercial buildings or light industrial markets for CHP or power-only applications.

Technology Specifications

A summary of the technology specifications is shown in **Table 3.3**.^{9,10} Microturbine developers quote an electrical efficiency at the high-frequency generator terminals of 30-33% on a lower heating value (LHV) basis.* The power electronics component then introduces about 5% in additional losses in the conversion step from high frequency to 60 Hz power. Additional parasitic loads of up to 10% of the capacity are often required for a fuel compressor necessary to compress natural gas from typical delivery pressures of 2 psig or less to 75 psig. These adjustments bring the electrical efficiency down to below 26% in our current market configuration. Future developments in the technology are expected to improve efficiencies and bring costs down significantly. Performance targets for the 2020 advanced systems are based on DOE goals in the recently released microturbine program solicitation. The O&M costs shown in the table represent the sum

* All turbine and engine manufacturers quote heat rates in terms of the lower heating value (LHV) of the fuel. On the other hand, the energy content of fuels is typically measured on a higher heating value basis (HHV). The energy measurements in EIA publications are measured in higher heating value, as are electric utilities' measurements power plant heat rates. The difference between HHV and LHV is the energy content of the water vapor in the combustion exhaust. Since, heat engines never capture this heat of vaporization, nor do heat recovery steam generators, design engineers prefer to quote efficiencies in LHV. For natural gas, the average heat content is 1030 Btu/cu ft on an HHV basis and 930 Btu/cu ft on an LHV basis – or about a 10% difference. Since all of the fuel data in NEMS is based on higher heating values, we converted the manufacturer's heat rates to an HHV basis.

of variable and fixed costs for a baseload system (8000 hours/year) expressed as a fixed cost per unit of output. The details of how these costs were derived are explained in Section 3.7.

Capital Cost Details

Microturbine systems are just now entering the market. Costs are high for these current *early market entry* units. The current units have expensive power electronics components, nonstandard generators, and complex recuperators. The basic design of the prime mover is quite simple. It is expected that continued cost engineering and higher volume production will bring costs down significantly during the forecast period. To date, developers have been very optimistic about how cheaply they will be able to engineer and install these units in a CHP application. Installation costs are based on experience with engine driven packaged microcogeneration systems that have been in the market for nearly twenty years. **Table 3.4** provides the detailed study estimate of capital costs for the current unit and for the advanced system that is expected to be available by the end of the NEMS forecasting period.

Table 3.3. Microturbine Cost and Performance Summary

CHP Cost and Performance Assumptions*	100 kW Microturbine	
	Current	2020
Total Installed Cost (99 \$/kW)	\$1,970	\$915
O&M Costs (\$/kWyear)	\$90.00	\$75.00
Elec. Heat Rate (Btu/kWh), HHV	13,306	9,477
Elec. Generating Efficiency, HHV (3412/Heat Rate)	25.7%	36.0%
Thermal Energy (Btu/kWh)		
Exhaust	4498	2748
Cooling Water	N/A.	N/A.
Overall Efficiency (%)	59%	65%
Thermal Recov. Eff.	45%	46%
Power to Heat Ratio	0.759	1.24
Net Elec. Heat Rate (Btus/kWh)	7,684	6,042

* System performance for the base case system was based on initial Honeywell Energy Systems (formally Allied Signal) product information for the Parallon 75.⁹ Base case package costs are based on initial introduction costs and advanced case package costs are based on mature market projections that have been made by Honeywell and others. Published performance data was adjusted to take into account heat losses from the power electronics package and parasitic power for the fuel gas compressor. Installed CHP system costs were based on component prices (heat recovery, gas compression) provided by Unicom²⁴ with OSEC estimates for engineering and construction based on OSEC experience with engine-driven microcogeneration plants.

Table 3.4 Microturbine Capital Cost Detail for Current and Advanced Units

Cost Component	100 kW Microturbine	
	Current	2020
Size kW	100	100
Package Cost (\$/kW)	\$800	\$350
Heat Recovery	\$150	\$150
Interconnect/Switchgear	\$100	\$50
Miscellaneous Equipment	\$135	\$40
Installation/Civil Work	\$210	\$120
Engineering and Management	\$130	\$55
General Contractor Markup	\$150	\$80
Contingencies and Guarantees	\$95	\$40
Carry Charges during Constr.	\$100	\$30
Total	\$1,970	\$915

3.4 Fuel Cell Power Systems

Fuel cells produce power electrochemically like a battery rather than like a conventional generating system that converts fuel to heat to shaft-power and finally to electricity. Unlike a storage battery, however, which produces power from stored chemicals, fuel cells produce power when hydrogen fuel is delivered to the *cathode* of the cell and oxygen in air is delivered to the *anode*. The resultant chemical reactions at each pole create a stream of electrons (or direct current) across the oppositely charged poles of the cell. The hydrogen fuel can come from a variety of sources, but the most economic is *steam reforming* of natural gas – a chemical process that strips the hydrogen from both the fuel and the steam. There are several different liquid and solid media that can be used to create the fuel cell's electrochemical reactions – phosphoric acid (PAFC), molten carbonate (MCFC), solid oxide (SOFC), and proton exchange membrane (PEM). Each of these media comprises a distinct fuel cell technology with its own performance characteristics and development schedule. PAFCs are in early commercial market development now with 200 kW units delivered to over 120 customers worldwide. The SOFC and MCFC technologies are now in field test or demonstration. PEM units are in early development and testing. Direct electrochemical reactions are generally more efficient than using fuel to drive a heat engine to produce electricity. Fuel cell efficiencies range from 35-40% for the PAFC to upwards of 60% with developing MCFC and SOFC systems. Fuel cells are inherently quiet and extremely clean running. Like a battery, fuel cells produce direct current (DC) that must be run through an inverter to get 60 Hz alternating current (AC). These power electronics components can be integrated with other components as part of a power quality control strategy for sensitive customers. Because of current high costs, fuel cells are best suited to environmentally sensitive areas and customers with power quality concerns. Some fuel cell technology is modular and capable of application in small commercial and even residential markets; other

technology utilizes high temperatures in larger sized systems that would be well suited to industrial cogeneration applications.

Technology Specifications

Table 3.5 summarizes the cost and performance specifications for fuel cell systems in CHP duty.¹¹ The current system is modeled after the early market entry phosphoric acid fuel cell (PAFC) that has entered the market in the last four years. The advanced system is not based on any one specific fuel cell design but represents an advance in efficiency and cost that could be achieved by one or more of the advanced systems under development today. The PAFC provides only a low temperature waste heat; however, such systems are compatible with many commercial applications that need hot water.

Capital Cost Details

Table 3.6 shows the study estimate for capital costs for the current and advanced fuel cell system. As previously described, the capital cost is based on the PAFC unit currently in the market. The capital cost estimate for the advanced fuel cell is not based on a specific developmental program goal, but reflects target forecasts for installed costs from developers of solid oxide and molten carbonate fuel cell systems.

Table 3.5. Fuel Cell Cost and Performance Summary

CHP Cost and Performance Assumptions*	200 kW Fuel Cell	
	Current	2020
Total Installed Cost (99 \$/kW)	\$3,674	\$1,433
O&M Costs (\$/kWyear)	\$87.00	\$72.50
Elec. Heat Rate (Btu/kWh), HHV	9,481	6,895
Elec. Generating Efficiency, HHV (3412/Heat Rate)	36.0%	49.5%
Thermal Energy (Btu/kWh)		
Exhaust	N/A.	N/A.
Cooling Water	3500	1700
Overall Efficiency (%)	73%	74%
Thermal Recov. Eff.	58%	49%
Power to Heat Ratio	0.975	2.008
Net Elec. Heat Rate (Btus/kWh)	5,106	4,770

* The base case fuel cell cost and performance is based on the ONSI PC25 model with a 200 kW rating. The advanced system was based on a review of cost and performance ranges prepared by the California Alliance for Distributed Energy Resources.¹¹ The cost and performance of the advanced system was based on a composite of second generation fuel cell technologies – molten carbonate, solid oxide, proton exchange membrane.

Table 3.6 Fuel Cell Capital Cost Detail for Current and Advanced Units

Cost Component	200 kW Fuel Cell	
	Current	2020
Size kW	200	200
Package Cost (\$/kW)	\$2,425	\$900
Heat Recovery	\$75	\$75
Interconnect/Switchgear	\$75	\$35
Miscellaneous Equipment	\$0	\$0
Installation/Civil Work	\$285	\$145
Engineering and Management	\$180	\$65
General Contractor Markup	\$310	\$125
Contingencies and Guarantees	\$105	\$40
Carry Charges during Constr.	\$220	\$45
Total	\$3,675	\$1,430

3.5 Reciprocating Engines

Reciprocating internal combustion (IC) engines are a widespread and well-known technology. North American production tops 35 million units per year for automobiles, trucks, construction and mining equipment, lawn care, marine propulsion, and of course all types of power generation from small portable *gen-sets* to engines the size of a house powering generators of several megawatts. Spark ignition engines for power generation use natural gas as the preferred fuel – though they can be set up to run on propane or gasoline. Diesel cycle, compression ignition engines can operate on diesel fuel or heavy oil, or they can be set up in a dual-fuel configuration that burns primarily natural gas with a small amount of diesel pilot fuel and can be switched to 100% diesel. Current generation recip engines offer low first cost, easy start-up, proven reliability when properly maintained, and good load-following characteristics. Emissions of recip engines have been reduced significantly in the last several years by exhaust catalysts and through better design and control of the combustion process. Recip engines are well suited for standby, peaking, and intermediate applications and for packaged CHP in commercial and light industrial applications of less than 10 MW.

Technology Specifications

Reciprocating engine cost and performance summaries are shown in **Table 3.7**.^{12,13,14,15,16} Engine systems can provide higher electrical efficiencies than combustion turbines in the small sizes. Because a significant portion of the waste heat from engine systems is rejected in the jacket water at a temperature generally too low to produce high-quality steam, the ability of engine systems to produce steam is limited. This feature is generally less critical in commercial applications where it is more common to have hot water loads. The thermal heat evaluation calculations are based on the use of both the jacket water and

the exhaust heat to produce hot water. In an industrial setting requiring steam, the thermal energy available would be lower.

Table 3.7. Summary Cost and Performance Specifications for Engine-Driven CHP

CHP Cost & Performance Assumptions*	100 kW IC-Eng.		800 kW IC-Eng.		3,000 kW IC-Eng.	
	Current	2020	Current	2020	Current	2020
Total Installed Cost (99 \$/kW)	\$1,390	\$990	\$975	\$690	\$850	\$710
O&M Costs (\$/kWyear)	\$131.20	\$109.33	\$85.20	\$71.00	\$82.70	\$68.92
Elec. Heat Rate (Btu/kWh), HHV	12,126	11,147	11,050	9,382	10,158	8,982
Elec. Generating Efficiency, HHV (3412/Heat Rate)	28.1%	30.6%	30.9%	36.4%	33.6%	38%
Thermal Energy (Btu/kWh)						
Exhaust	2273	2202	1491	1250	1934	1546
Jacket Water	3410	3303	2832	2374	975	1150
Overall Efficiency (%)	75%	80%	70%	75%	62%	68%
Thermal Recov. Eff.	65%	71%	58%	61%	42%	48%
Power to Heat Ratio	0.60	0.62	0.79	0.94	1.17	1.27
Net Elec. Heat Rate (Btus/kWh)	5,023	4,265	5,646	4,851	6,522	5,612

Engine systems can provide higher electrical efficiencies than combustion turbines in the small sizes. Because a significant portion of the waste heat from engine systems is rejected in the jacket water at a temperature generally too low to produce high-quality steam, the ability of engine systems to produce steam is limited. This feature is generally less critical in commercial applications where it is more common to have hot water loads. Steam can be produced from the exhaust heat in the same manner as from the exhaust of a combustion turbine, though the volume of exhaust per unit of electrical output is generally much lower. The jacket water for most systems is suitable only for production of hot water.

The 100 kW system is assumed to be a naturally aspirated engine whereas the two larger models are intercooled turbocharged engines. The larger engines have separate coolant flow to the turbochargers and also have oil coolers. It is not typical for heat from these subsystems to be recovered. For this reason, the small engine system has the highest overall efficiency – even though it has the lowest electrical efficiency.

The advanced case assumes that the larger engines approach current diesel cycle efficiency in the spark-ignited gas engine systems. This represents an evolutionary

* The 100 kW base system is based on product specifications for the Caterpillar G3306 gas engine generator set in a naturally aspirated high-compression ratio configuration. The advanced engine is based on proprietary target specifications for a second engine manufacturer whose product is still in the developmental stages. The midsize (800 kW) gas engine system was based on the Caterpillar G3516 engine system. The advanced performance was based on target specifications for a high performance system being developed by the Gas Research Institute and Caterpillar. Capital cost estimates are based on OSEC experience with both Caterpillar and Waukesha installations. The 3000 kW size is based on the Caterpillar G3616. The base case specifications are based on the current product performance. The advanced system is based on preliminary goals of the Advanced Reciprocating Engine System (ARES) program.^{12,15,16}

improvement of existing design and operation. A group of engine manufacturers has proposed a cooperative research effort that could ultimately raise the efficiency of the spark ignited recip engine to 45% on a HHV basis (50% LHV). The advanced case also assumes an increase in useful heat recovery (i.e., potential recovery from turbochargers and oil coolers in large engines).

Capital Cost Details

Table 3.8 provides study estimates of capital costs for the three sizes of recip engine CHP systems for commercial applications. For these systems, the total installed cost averages about double the cost of the basic engine generator and heat recovery equipment. The smallest engine systems are both more expensive on a \$/kW basis and also have higher added costs for installation. The multi-megawatt size engines are not cheaper than the 800 kW engines because they typically operate at medium to slow speed (600-900 rpm) whereas the smaller engines operate at higher speed (1200-1800 rpm). Smaller systems are better packaged and require less site work than larger systems but this effect is overcome by fairly strong economies of scale in developing, managing, and installing a larger system. One of the biggest examples of economies of scale is the cost of interconnection switchgear which runs \$150/kW for the 100 kW system to only \$33/kW for the largest system.

The technologically advanced systems show lower costs due to higher specific outputs (more power from the same block), advances in interconnect switchgear, more competitive pricing and experience in engineering and installation, and the impact of a developed sales and service infrastructure.

Table 3.8. Internal Combustion Engine CHP System Capital Costs for Commercial Applications (\$1999/kW)

Cost Component	100 kW Engine		800 kW Engine		3,000 kW Engine	
	Current	2020	Current	2020	Current	2020
Size kW	100	100	800	800	3,000	3000
Package Cost (\$/kW)	\$550	\$400	\$430	\$300	\$380	\$320
Heat Recovery	\$100	\$90	\$75	\$60	\$65	\$75
Interconnect/Switchgear	\$150	\$75	\$60	\$35	\$35	\$20
Miscellaneous Equipment	\$70	\$70	\$50	\$50	\$50	\$50
Installation/Civil Work	\$150	\$100	\$105	\$70	\$90	\$70
Engineering and Management	\$90	\$60	\$60	\$40	\$60	\$40
General Contractor Markup	\$150	\$105	\$105	\$70	\$90	\$70
Contingencies and Guarantees	\$60	\$40	\$40	\$30	\$35	\$30
Carrying Charges during Constr.	\$70	\$50	\$50	\$35	\$45	\$35
Total (\$/kW)	\$1,390	\$990	\$975	\$690	\$850	\$710

3.6 Combustion Turbines

Combustion turbines (CT) are an established technology in sizes from several hundred kilowatts to hundreds of megawatts. CTs are used to power aircraft, large marine vessels, gas compressors, and utility and industrial power generators. CTs produce high quality heat that can be used to generate steam for additional power generation (combined cycle) or onsite steam use. CTs can be set up to burn natural gas or a variety of petroleum fuels or can have a dual-fuel configuration. CT emissions can be controlled to very low levels using dry combustion techniques, water or steam injection, or exhaust treatment such as selective catalytic reduction (SCR). Maintenance costs per unit of power output are among the lowest of CHP technology options. Low maintenance and high quality waste heat make CTs an excellent choice for industrial or commercial cogeneration applications larger than 5 MW.

Technology Specifications

Table 3.9 summarizes the turbine cost and performance parameters for three sizes and the two time periods.^{17,18,19,20,21} The sizes are 1, 5, and 10 MW, and the time periods reflect the current specifications and those that would be appropriate for the end-point of the NEMS modeling – 2020. The heat rates for the current Combustion turbines (CTs) are taken from published data for popular turbines in each size class. Thermal energy was calculated from published turbine data on steam available from selected systems. The estimates are based on an unfired heat recovery steam generator (HRSG) producing dry, saturated steam at 150 psig. The performance specifications for the 2020 systems are based on advanced technology that is just now becoming available in the market. The 5 MW system is based on a recuperated cycle system that was developed cooperatively by industry and the Department of Energy in the Advanced Turbine System program. The 10 MW system reflects a small-scale combined cycle system. The 1 MW system is based on the assumption that performance will approach the current performance for the 5 MW system.

The derived data in the table show that as CTs become larger, their electrical efficiency increases. As electrical efficiency increases, the absolute quantity of steam produced goes down and the ratio of power to heat increases. A changing ratio of power to heat may affect the decisions that customers make in terms of CHP acceptance, sizing, and the need to sell power.

Table 3.9. Summary Cost and Performance for Combustion Turbine CHP Systems

CHP Cost & Performance Assumptions*	1,000 kW CT		5,000 kW CT		10,000 kW CT	
	Current	2020	Current	2020	Current	2020
Total Installed Cost (99 \$/kW)	\$1,600	\$1,340	\$1,075	\$950	\$965	\$830
O&M Costs (\$/kWyear)	\$76.80	\$64.00	\$46.80	\$39.00	\$44.30	\$36.92
Elec. Heat Rate (Btu/kWh), HHV	15,600	12,375	12,375	9,605	11,750	9,054
Elec. Generating Efficiency, HHV (3412/Heat Rate)	21.9%	27.6%	27.6%	35.5%	29.0%	37.7%
Thermal Energy (Btu/kWh)	7,820	5,622	5,622	3,709	5,283	3,280
Overall Efficiency (%)	72%	73%	73%	74%	74%	74%
Thermal Recov. Eff.	64%	63%	63%	60%	63%	58%
Power Steam Ratio	0.436	0.607	0.607	.920	0.646	1.041
Net Elec. Heat Rate (Btus/kWh)	5825	5348	5348	4967	5146	4954

Capital Cost Details

The detailed capital costs for the current and advanced CT-CHP systems are shown in **Table 3.10**.^{17,19,20,21} A CT-CHP plant is a complex process with many interrelated subsystems. The system is designed around key equipment components. The most important is the turbine-generator set. Prices typically range from \$300-400 per kW except for the 1 MW size which is considerably more expensive on a unit cost basis. A heat recovery steam generator (HRSG) accomplishes the heat recovery. The next most important subsystem is the electrical switchgear and controls. After these main components there are still a large number of smaller components such as enclosures or buildings, water treatment systems, piping, pumps, storage tanks, equipment foundations and superstructures, fire suppression systems, and emissions control and monitoring equipment. Site preparation can be a significant cost for some projects. Labor and materials for plant construction are also a major part of overall costs. The sum of these costs is termed *total process capital* in our table. To total process capital must be added engineering, general contractor fees, permitting fees, contingency, and financing costs. These costs add an additional 20% to total process capital to provide an estimate of total capital cost. The cost estimates do not include costs for exhaust treatment using SCR.

* Base case gas turbines are based on published specifications¹⁸ and package prices.¹⁷ The capital cost estimation is based on the use of a proprietary cost and performance model – SOAPP-CT.25 – (for State-of-the-Art Power Plant, combustion turbine).¹⁹ The model output was adjusted based on OSEC engineering judgment and experience. The base case 1 MW size is based on the Solar 1205 kW Saturn 20 gas turbine. The 5 MW system is based on the Solar Taurus 60. The 10 MW system is based on the Solar Mars 100. The advanced case 1 MW system is based on a qualitative assessment of potential efficiency improvement based on recuperation. The advanced 5 MW system is based on the 4.2 MW Solar Mercury 50, a recuperated turbine system that was the successful product of the DOE Advanced Turbine System program. The advanced 10 MW system is based on the Mitsui SB60 (17.7 MW) combined cycle turbine system.

The advanced capital costs are estimated based on the assumption that miscellaneous equipment, materials, and labor would be reduced by 20%. This reduction reflects the expectation that CHP system installation will become more streamlined in the future and that packaged systems will require less onsite labor and materials. The costs for the basic turbine generator package and heat recovery are also assumed to be reduced, but only by 10%. Cost engineering is expected to bring costs down, but additional equipment such as recuperators and more costly materials for the advanced CTs is expected to partially offset the cost engineering improvements.

Table 3.10. Capital Cost Estimates for CHP Plants Based on Combustion Turbines

Nominal Turbine Capacity , kW	1,000 kW CT		5,000 kW CT		10,000 kW CT	
	Current	2020	Current	2020	Current	2020
Combustion Turbines	\$550,000	\$467,500	\$2,102,940	\$1,892,646	\$4,319,200	\$3,887,280
Heat Recovery Steam Generators	\$250,000	\$225,000	\$350,000	\$315,000	\$590,000	\$531,000
Water Treatment System	\$30,000	\$30,000	\$100,000	\$100,000	\$150,000	\$150,000
Electrical Equipment	\$150,000	\$120,000	\$375,000	\$300,000	\$625,000	\$500,000
Other Equipment	\$145,000	\$115,700	\$315,000	\$255,000	\$575,000	\$460,000
Total Equipment	\$1,125,000	\$958,200	\$3,242,940	\$2,862,646	\$6,259,200	\$5,528,280
Materials	\$143,952	\$115,162	\$356,723	\$285,379	\$688,512	\$550,810
Labor	\$347,509	\$278,007	\$908,023	\$726,419	\$1,752,576	\$1,402,061
Total Process Capital \$	\$1,616,461	\$1,351,369	\$4,507,686	\$3,974,443	\$8,700,288	\$7,481,150
General Facilities Capital \$	\$48,483	\$40,541	\$135,231	\$116,233	\$261,009	\$224,435
Engineering and Fees \$	\$48,483	\$40,541	\$135,231	\$116,233	\$261,009	\$224,435
Process Contingency \$	\$48,483	\$40,541	\$135,231	\$116,233	\$261,009	\$224,435
Project Contingency \$	\$171,305	\$143,245	\$477,815	\$421,290	\$922,231	\$793,002
Total Plant Cost \$	\$1,933,215	\$1,616,237	\$5,391,193	\$4,744,432	\$10,405,544	\$8,947,456
Actual Turbine Capacity (kW)	1,205	1,205	5,007	5,007	10,798	10,798
Total Plant Cost per net kW \$	\$1,604	\$1,341	\$1,076	\$948	\$964	\$829

3.7 Operating and Maintenance Costs

The operating and maintenance costs presented in **Table 3.11** include total maintenance costs including routine inspections and procedures and major overhauls. O&M costs presented in **Table 3.11** are based on 8,000 operating hours expressed in terms of annual electricity generation. Fixed costs are based on an interpolation of manufacturers' estimates. The variable component of the O&M cost represents the inspections and overhaul procedures that are normally conducted by the prime mover OEM through a service agreement usually based on run hours. It is recognized, however, that there is a fixed component aspect to original equipment manufacturer (OEM) service agreements as well. However, for purposes of clarity, the information is presented as a variable cost. Consumables include primarily an estimate for water and chemicals that are consumed in proportion to electric capacity. All costs shown are for current systems. For purposes of the NEMS modeling estimates, we assume a 20% reduction of O&M costs for the advanced systems.

Microturbines and Fuel Cells

O&M costs for these developing technologies are based on the report of the Technology Characterization Committee for the Collaborative Report of the California Alliance for Distributed Energy Resources.¹¹ These costs were adjusted somewhat for consistency with the estimates developed below for reciprocating engines and combustion turbines.

Reciprocating Internal Combustion Engines

O&M costs presented in **Table 3.11** are based on engine manufacturer estimates for service contracts consisting of routine inspections and scheduled overhauls of the engine generator set.^{12,13,22} Engine service is comprised of routine inspections/adjustments and periodic replacement of engine oil, coolant and spark plugs. An oil analysis is part of most preventative maintenance programs to monitor engine wear. A top-end overhaul is generally recommended between 12,000-15,000 hours of operation that entails a cylinder head and turbocharger rebuild. A major overhaul is performed after 24,000-30,000 hours of operation and involves piston/liner replacement, crankshaft inspection, bearings and seals.

Gas Turbines

O&M costs presented in **Table 3.11** are based on gas turbine manufacturer estimates for service contracts consisting of routine inspections and scheduled overhauls of the turbine generator set.^{20,23} Routine maintenance practices include on-line running maintenance, predictive maintenance, plotting trends, performance testing, fuel consumption, heat rate, vibration analysis, and preventive maintenance procedures.

Routine inspections are required to insure that the turbine is free of excessive vibration due to worn bearings, rotors and damaged blade tips. Inspections generally include on-site hot gas path borescope inspections and non-destructive component testing using dye

penetrant and magnetic particle techniques to ensure the integrity of components. The combustion path is inspected for fuel nozzle cleanliness and wear along with the integrity of other hot gas path components.

A gas turbine overhaul is typically a complete inspection and rebuild of components to restore the gas turbine to original or current (upgraded) performance standards. A typical overhaul consists of dimensional inspections, product upgrades and testing of the turbine and compressor, rotor removal, inspection of thrust and journal bearings, blade inspection and clearances and setting packing seals.

Gas turbine maintenance costs can vary significantly depending on the quality and diligence of the preventative maintenance program and operating conditions. Although gas turbines can be cycled, maintenance costs can triple for a gas turbine that is cycled every hour versus a turbine that is operated for intervals of a 1000 hours or more. In addition, operating the turbine over the rated capacity for significant periods of time will dramatically increase the number of hot path inspections and overhauls. Gas turbines that operate for extended periods on liquid fuels will experience higher than average overhaul intervals.

Table 3.11a. O&M Cost Estimates

Technology	Size kW	Variable Costs \$/kWh		Fixed Costs \$/kW-year	Total O&M \$/kWh*
		Service Contract	Consumables		
Microturbine	100	\$0.00500		\$50.00	\$0.01125
Fuel Cell	200	\$0.00900		\$15.00	\$0.01088
Reciprocating Engine	100	\$0.01500	\$0.00015	\$10.00	\$0.01640
Reciprocating Engine	800	\$0.01000	\$0.00015	\$4.00	\$0.01065
Reciprocating Engine	3,000	\$0.01000	\$0.00015	\$1.50	\$0.01034
Combustion Turbine	1,000	\$0.00450	\$0.00010	\$40.00	\$0.00960
Combustion Turbine	5,000	\$0.00450	\$0.00010	\$10.00	\$0.00585
Combustion Turbine	10,000	\$0.00450	\$0.00010	\$7.50	\$0.00554

* Total Costs based on 8,000 hours of operation per year

Table 3.11b O&M Total Costs Expressed in Terms of Total Costs per Year per Kilowatt (not additive with previous table)

Technology	Size kW	Total O&M \$/kW-year*
Microturbine	100	\$90.00
Fuel Cell	200	\$87.00
Reciprocating Engine	100	\$131.20
Reciprocating Engine	800	\$85.20
Reciprocating Engine	3,000	\$82.70
Combustion Turbine	1,000	\$76.80
Combustion Turbine	5,000	\$46.80
Combustion Turbine	10,000	\$44.30

* based on 8,000 hours/year of operation

4. References

1. *Commercial Buildings Energy Consumption Survey, 1995*, U.S.DOE, Energy Information Administration, Washington, DC, 1998
2. *Independent Power Database*, Hagler, Bailly Consulting Inc, Arlington, VA, 1999
3. *Small Cogeneration Market Review*, Draft Report, Gas Research Institute, Chicago, IL, 1996
4. *Commercial Market Segmentation Study: Education Sector*, GRI, AGA, 1998
5. *Commercial Market Segmentation Study: Health Care Sector*, GRI, AGA, 1998
6. *Commercial Market Segmentation Study: Lodging Sector*, GRI, AGA, 1998
7. *Commercial Market Segmentation Study: Education Sector*, GRI, AGA, 1998
8. *MarketPlace Database*, iMarket Inc, Waltham, MA., 1999
9. Product Demonstration Presentation, Allied Signal Parallon 75, Chicago, IL, November 10, 1999
10. *Cooperative Research and Development for Advanced Microturbine Systems*, Solicitation for Financial Assistance Applications, No. DE-SC02-00CH11016, U.S.DOE, Argonne, IL
11. "Distributed Energy Technology Matrix", *Collaborative Report and Action Agenda*, California Alliance for Distributed Energy Resources, Sacramento, CA, January, 1998
12. Caterpillar Datasheets, G3306, G3516, G3616, Caterpillar Inc., 1998
13. Waukesha Datasheet, 5790GL, Waukesha Engines, 1998
14. Heat Recovery Datasheet, Waukesha 5790GL, Maxim Co., 1995
15. Liss, W.E., Kincaid, D.E., *Distributed Generation Using High Power Output, High Efficiency Natural Gas Engines*, , Gas Research Institute, American Power Conference, 1999
16. *Program Summary: Advanced Reciprocating Engine Systems (ARES)*, 1999
17. *1998-1999 Gas Turbine World Handbook*, Pequot Publishing, 1999

18. *Diesel & Gas Turbine Worldwide Catalog: Product Directory & Buyers Guide*, Brookfield, Wisconsin, 1997.
19. SOAPP-CT.25 Workstation: Version 1, SEPRIL, llc, January 1999
20. Personal communications with M. Jurgensen, Solar Turbines Inc., January 2000
21. Personal communications with M. Scorrano, Trigen Energy Corp.
22. Personal communications with G. Deale, Hawthorne Power Systems
23. Personal communications with J. Polk, General Electric Co.
24. Personal communications with R. Krajcovic, Unicom

Appendix A - Profile of Existing Commercial/Institutional CHP

Table A1. Commercial CHP Installations, Electric and Thermal Capacity by Fuel Type

Table A2. Commercial CHP Installations and Capacity by State and Fuel Type

Table A3. Commercial CHP Installations, Electric and Thermal Capacity by State and Prime Mover

Table A4. Commercial CHP Installations, Electric and Thermal Capacity by Application and Prime Mover

Table A5. Commercial CHP Installations and Capacity by Application and Ownership

Table A6. Commercial CHP Installations and Capacity by Applications and Utility Sales Arrangements

Table A7. Commercial CHP Installations and Capacity by State and by Utility Sales Arrangements

Table A8. Commercial CHP Installations and Capacity by Size Range and Fuel Type

Table A9. Commercial CHP Installations and Capacity by State and Prime Mover

Table A10. Commercial CHP Installations and Capacity by Ownership and Prime Mover

Table A11. Commercial CHP Installations and Capacity by Sales Arrangements and Prime Mover

Table A12. Commercial CHP Installations and Capacity by Prime Mover and Fuel Type

Table A13. Commercial CHP Installations and Capacity by Size Range and Prime Mover

Data in these tables based on the Hagler, Bailly *Independent Power Database* updated by OSEC

Table A1. Commercial CHP Installations, Electric and Thermal Capacity by Fuel Type

	Coal	Natural Gas	Oil	Waste	Wood	Other	Totals
Warehousing & Storage		4 58.29 233	1 3.00 12	1 0.08 0			6 61.37 245
Airports		7 151.44 606	1 5.50 22			1 13.50 54	9 170.44 682
Water Treatment		12 116.03 464	1 0.01 0	1 3.00 12		12 21.89 88	26 140.93 564
Solid Waste Facilities				9 372.45 3,270		2 5.80 23	11 378.25 3,293
District Energy/ Utilities	3 88.50 500	16 728.39 1,959	1 54.00 485	2 31.70 385	1 39.60 360	5 12.50 81	28 954.69 3,770
Food Stores		10 1.38 6					10 1.38 6
Restaurants		11 0.91 4	1 0.27 1			1 0.07 0	13 1.25 5
Commercial Office Buildings & Facilities	1 70.00 560	45 109.60 569	2 5.73 23	1 28.00 280		3 22.05 208	52 235.38 1,640
Apartment Buildings		97 95.38 650	1 0.98 4				98 96.35 653
Hotels		78 25.74 136	2 3.39 11			3 1.04 4	83 30.16 151
Laundries		76 3.27 13				2 0.03 0	78 3.30 13
Car Washes		2 0.16 1		4 0.15 1			6 0.31 1
Health & Country Clubs		81 163.06 403	3 1.21 5			1 0.03 0	85 164.30 408
Nursing Homes	1 1.00 15	72 9.68 41					73 10.68 56
Hospitals	1 5.00 75	119 413.16 1,593	8 16.07 145	1 55.00 220	1 2.00 30	1 0.15 2	131 491.38 2,065
Elementary & Primary Schools		101 13.69 55	1 0.12 0			4 0.42 2	106 14.23 57

Table A1 continued

	Coal	Natural Gas	Oil	Waste	Wood	Other	Totals
Colleges & Universities	8 215.57 2,032	93 1,103.90 3,856	8 20.36 249	1 62.00 488	1 1.13 16	1 11.00 44	112 1,413.95 6,685
Museums		2 3.79 30					2 3.79 30
Government Facilities	4 60.65 606	26 501.45 2,105		3 57.20 613			33 619.30 3,324
Prisons		14 48.00 195		2 45.70 455	1 4.00 60	1 37.00 148	18 134.70 858
<i>Totals</i>	18	866	30	25	4	37	980
Totals	440.72	3,547.31	110.62	655.28	46.73	125.48	4,926.13
<i>Totals</i>	3,788	12,918	957	5,724	466	654	24,507

Key:	
<i>Number of Sites</i>	12
Electrical Capacity, MW	42.67
<i>Thermal Capacity, mmBtu/Hour</i>	207

Table A2. Commercial CHP Installations and Capacity by State and Fuel Type

	Coal	Natural Gas	Oil	Waste	Wood	Other	Totals
AK		5 12.70	1 0.33				6 13.02
AL		1 3.00					1 3.00
AR		2 12.60					2 12.60
AZ		14 5.81					14 5.81
CA		429 795.27				18 55.52	447 850.79
CO		5 109.50				1 0.70	6 110.20
CT		43 106.01	4 8.80	1 18.00			48 132.81
FL		8 53.22	3 12.81	1 70.00	1 39.60	1 0.13	14 175.75
GA			1 0.01				1 0.01
HI	1 64.50	4 0.30	1 0.12				6 64.92
IA		6 5.64					6 5.64
ID						1 20.00	1 20.00
IL	3 49.00	21 52.06					24 101.06
IN	1 40.00	3 5.55				1 0.20	5 45.75
KY		1 0.40					1 0.40
MA		29 95.33	1 1.81				30 97.13
MD	1 10.00			1 60.00	1 4.00		3 74.00
ME			1 0.01		1 1.13		2 1.14
MI	1 61.00	15 74.24		4 82.78		1 1.60	21 219.62
MN		2 5.35		1 4.20			3 9.55
MO	3 53.00	3 19.90					6 72.90
MS		1 4.35					1 4.35
MT						1 0.15	1 0.15

NC	1	28.00					1	28.00
NE		0.08				1	2	0.98
NH			3	6.37		1	4	8.37
NJ		100		2	98.00		4	106
		100.86					4	202.34
NM		6				1	7	13.22
		10.96						
NV		1					1	0.02
		0.02						
NY	2	98	10	4		2	116	
	57.80	908.91	9.99	88.26		2.94	1,067.89	
OH	1	6					7	
	0.77	4.16						4.93
OK		1					1	
		16.30						16.30
PA	2	21	1	5			29	
	0.65	291.32	54.00	112.76				458.73
RI		5					5	
		1.09						1.09
SC	2			1			3	
	76.00			15.00				91.00
SD		1					1	
		2.70						2.70
TN		3				3	6	
		15.40				31.80		47.20
TX		18	1				19	
		449.06	0.24					449.30
UT		3					3	
		5.25						5.25
VA		3	1	2		2	8	
		123.72	3.00	43.00		5.80		175.52
VT		2					2	
		0.11						0.11
WA		1					1	
		3.59						3.59
WI		3	1	2			6	
		252.35	10.00	1.28				263.63
WV		1	1	1			3	
		0.24	3.15	62.00				65.39
Totals	18	866	30	25	4	37	980	
Totals	440.72	3,547.31	110.62	655.28	46.73	125.48	4,926.13	

Key:	
Number of Sites	12
Electrical Capacity, MW	42.67

Table A3. Commercial CHP Installations, Electric and Thermal Capacity by Applications and Prime Mover

	Boiler/Steam Turbine	Combined Cycle	Combustion Turbine	Reciprocating Engine	Other	Totals
Warehousing & Storage			2 56.00 224	4 5.37 21		6 61.37 245
Airports		2 137.00 548	1 14.00 56	4 5.76 23	2 13.68 55	9 170.44 682
Water Treatment			1 49.40 198	25 91.53 366		26 140.93 564
Solid Waste Facilities	9 372.45 3,270			2 5.80 23		11 378.25 3,293
District Energy/ Utilities	7 152.09 1,577	6 739.47 1,919	2 18.75 95	10 36.53 146	3 7.85 33	28 954.69 3,770
Food Stores				10 1.38 6		10 1.38 6
Restaurants				12 1.21 5	1 0.04 0	13 1.25 5
Commercial Office Buildings & Facilities	4 121.00 1,085		12 56.39 323	34 57.14 229	2 0.85 3	52 235.38 1,640
Apartment Buildings	2 38.00 456	1 34.00 100		95 24.35 97		98 96.35 653
Hotels			4 8.05 65	77 21.01 81	2 1.10 4	83 30.16 151
Laundries				76 3.20 13	2 0.10 0	78 3.30 13
Car Washes				6 0.31 1		6 0.31 1
Health & Country Clubs		2 149.80 350	1 0.11 0	82 14.39 58		85 164.30 408
Nursing Homes	2 1.23 18			71 9.46 38		73 10.68 56
Hospitals	7 69.45 437	5 229.41 688	30 96.72 556	86 95.00 380	3 0.80 3	131 491.38 2,065
Elementary & Primary Schools			1 0.06 0	104 13.97 56	1 0.20 1	106 14.23 57

Colleges & Universities	15 294.63 2,775	7 449.60 1,037	39 563.31 2,439	49 95.21 389	2 11.20 45	112 1,413.95 6,685
Museums				2 3.79 30		2 3.79 30
Government Facilities	11 242.55 2,501	3 342.50 643	7 21.70 130	12 12.55 50		33 619.30 3,324
Prisons	3 49.70 515	1 28.14 85	4 48.80 226	9 7.87 31	1 0.20 1	18 134.70 858
Totals	60 1,341.10 12,634	27 2,109.92 5,370	104 933.28 4,313	770 505.81 2,044	19 36.02 146	980 4,926.13 24,507

Key:	
<i>Number of Sites</i>	12
Electrical Capacity, MW	42.67
<i>Thermal Capacity, MMBtu/Hour</i>	207

Table A4. Commercial CHP Installations, Electric and Thermal Capacity by State and Prime Mover

State	Boiler/Steam Turbine	Combined Cycle	Combustion Turbine	Reciprocating Engine	Other	Totals
AK			2 6.15	4 6.87		6 13.02
AL			1 3.00			1 3.00
AR				2 12.60		2 12.60
AZ			2 1.45	12 4.36		14 5.81
CA	4 110.20	9 281.45	35 318.07	388 138.24	11 2.84	447 850.79
CO		1 33.00	1 76.00	4 1.20		6 110.20
CT	5 26.80	1 56.00	7 45.40	35 4.61		48 132.81
FL	2 109.60	1 27.50	3 17.25	8 21.41		14 175.75
GU				1 0.01		1 0.01
HI		1 64.50		5 0.42		6 64.92
IA				6 5.64		6 5.64
ID	1 20.00					1 20.00
IL	3 49.00		5 27.20	16 24.86		24 101.06
IN	1 40.00		1 2.75	2 2.80	1 0.20	5 45.75
KY				1 0.40		1 0.40
MA		1 64.00	1 22.00	27 10.78	1 0.35	30 97.13
MD	3 74.00					3 74.00
ME	1 1.13			1 0.01		2 1.14
MI	4 143.70		7 68.46	10 7.46		21 219.62
MN	1 4.20		1 5.20	1 0.15		3 9.55
MO	3 53.00		1 15.45	2 4.45		6 72.90
MS			1 4.35			1 4.35

MT				1	0.15		1	0.15
NC	1	28.00					1	28.00
NE				2	0.98		2	0.98
NH	2	5.00		2	3.37		4	8.37
NJ	3	98.23		12	74.50	90	1	106
					29.16		0.45	202.34
NM				2	7.17	5		7
					6.05			13.22
NV						1		1
					0.02			0.02
NY	10	187.44	7	4	130.50	95		116
		670.00			79.96			1,067.89
OH	1	0.77		3	3.28	3		7
					0.88			4.93
OK				1	16.30			1
								16.30
PA	7	184.85	1	4	20.67	15	2	29
		183.97			68.86		0.38	458.73
RI						5		5
					1.09			1.09
SC	3	91.00						3
								91.00
SD						1		1
					2.70			2.70
TN				3	15.40		3	6
					31.80			47.20
TX	1	0.94	3	5	48.90	10		19
		361.00			38.46			449.30
UT						3		3
					5.25			5.25
VA	1	40.00	1		120.00	6		8
					15.52			175.52
VT						2		2
					0.11			0.11
WA						1		1
					3.59			3.59
WI	2	11.25	1	2	248.50	1		6
					3.85			263.63
WV	1	62.00				2		3
					3.39			65.39
Totals	60		27	104		770	19	980
Totals		1,341.10	2,109.92		933.28	505.81	36.02	4,926.13

Key:	
Number of Sites	12
Electrical Capacity, MW	42.67

Table A5. Commercial CHP Installations and Capacity by Application and Ownership

	3 rd Party	Self	Totals
Warehousing & Storage	4 59.08	2 2.29	6 61.37
Airports	3 107.26	6 63.18	9 170.44
Water Treatment	6 40.11	20 100.82	26 140.93
Solid Waste Facilities	10 374.05	1 4.20	11 378.25
District Energy/ Utilities	22 928.93	6 25.76	28 954.69
Food Stores	8 1.17	2 0.21	10 1.38
Restaurants	12 1.24	1 0.01	13 1.25
Commercial Office Buildings	28 131.73	24 103.65	52 235.38
Apartment Buildings	75 44.27	23 52.08	98 96.35
Hotels	65 11.79	18 18.38	83 30.16
Laundries	68 1.63	10 1.67	78 3.30
Car Washes	5 0.21	1 0.10	6 0.31
Health & Country Clubs	61 155.25	24 9.05	85 164.30
Nursing Homes	60 5.41	13 5.27	73 10.68
Hospitals	54 323.41	77 167.97	131 491.38
Elementary & Primary Schools	57 4.82	49 9.41	106 14.23
Colleges & Universities	31 624.19	81 789.76	112 1,413.95
Museums	1 0.09	1 3.70	2 3.79
Government Facilities	8 485.76	25 133.54	33 619.30
Prisons	9 79.65	9 55.06	18 134.70
Totals	587 3,380.04	393 1,546.09	980 4,926.13

Key:	
Number of Sites	12
Electrical Capacity, MW	42.67

Table A6. Commercial CHP Installations and Capacity by Applications and Utility Sales Arrangements

	No		Yes		Totals	
Warehousing & Storage	2	1.38	4	59.99	6	61.37
Airports	6	33.26	3	137.18	9	170.44
Water Treatment	13	27.27	13	113.66	26	140.93
Solid Waste Facilities			11	378.25	11	378.25
District Energy/ Utilities	8	12.93	20	941.76	28	954.69
Food Stores	10	1.38			10	1.38
Restaurants	11	1.20	2	0.05	13	1.25
Commercial Office Buildings	35	132.80	17	102.58	52	235.38
Apartment Buildings	83	55.69	15	40.66	98	96.35
Hotels	65	18.32	18	11.84	83	30.16
Laundries	71	2.97	7	0.33	78	3.30
Car Washes	6	0.31			6	0.31
Health & Country Clubs	73	12.04	12	152.26	85	164.30
Nursing Homes	70	7.15	3	3.54	73	10.68
Hospitals	86	116.66	45	374.72	131	491.38
Elementary & Primary Schools	94	12.13	12	2.10	106	14.23
Collages & Universities	77	553.54	35	860.41	112	1,413.95
Museums	1	0.09	1	3.70	2	3.79
Government Facilities	10	45.36	23	573.94	33	619.30
Prisons	10	48.89	8	85.81	18	134.70
Totals	731	1,083.35	249	3,842.78	980	4,926.13

Key:	
Number of Sites	12
Electrical Capacity, MW	42.67

Table A7. Commercial CHP Installations and Capacity by State and by Utility Sales Arrangements

	No	Yes	Totals
AK	2 6.15	4 6.87	6 13.02
AL	1 3.00		1 3.00
AR		2 12.60	2 12.60
AZ	11 4.67	3 1.14	14 5.81
CA	330 189.42	117 661.37	447 850.79
CO	1 0.04	5 110.16	6 110.20
CT	38 28.51	10 104.30	48 132.81
FL	10 24.11	4 151.65	14 175.75
GU	1 0.01		1 0.01
HI	5 0.42	1 64.50	6 64.92
IA	4 2.08	2 3.56	6 5.64
ID		1 20.00	1 20.00
IL	19 62.70	5 38.36	24 101.06
IN	5 45.75		5 45.75
KY	1 0.40		1 0.40
MA	25 25.72	5 71.42	30 97.13
MD	1 10.00	2 64.00	3 74.00
ME	1 1.13	1 0.01	2 1.14
MI	15 30.82	6 188.80	21 219.62
MN	2 5.35	1 4.20	3 9.55
MO	4 57.30	2 15.60	6 72.90
MS	1 4.35		1 4.35

MT		1	0.15	1	0.15
NC	1		28.00	1	28.00
NE	2		0.98	2	0.98
NH	3	1	6.37	4	8.37
			2.00		
NJ	96	10	57.73	106	202.34
			144.61		
NM	6	1	11.74	7	13.22
			1.48		
NV	1		0.02	1	0.02
NY	88	28	107.74	116	1,067.89
			960.15		
OH	4	3	3.35	7	4.93
			1.58		
OK	1		16.30	1	16.30
PA	14	15	40.69	29	458.73
			418.04		
RI	5		1.09	5	1.09
SC	1	2	70.00	3	91.00
			21.00		
SD	1		2.70	1	2.70
TN	5	1	39.90	6	47.20
			7.30		
TX	16	3	184.12	19	449.30
			265.18		
UT	3		5.25	3	5.25
VA	1	7	0.72	8	175.52
			174.80		
VT	2		0.11	2	0.11
WA	1		3.59	1	3.59
WI	2	4	0.83	6	263.63
			262.80		
WV	1	2	0.24	3	65.39
			65.15		
<i>Totals</i>	731	249		980	
Totals	1,083.35	3,842.78	4,926.13		

Key:	
<i>Number of Sites</i>	12
Electrical Capacity, MW	42.67

Table A8. Commercial CHP Installations and Capacity by Size Range and Fuel Type

Size Range	Coal	Natural Gas	Oil	Waste	Wood	Other	Totals
0 – 999 kW	3 1.42	661 102.18	15 6.94	5 0.23		21 7.16	705 117.93
1.0 – 4.9 MW	1 1.00	112 270.52	9 22.28	5 14.35	3 7.13	10 22.01	140 337.28
5.0 – 9.9 MW	4 24.80	30 190.58	4 17.41			2 14.80	40 247.58
10.0 – 14.9 MW	1 10.00	18 225.97	1 10.00	1 14.00		2 24.50	23 284.47
15.0 – 19.9 MW	1 18.00	4 67.25		4 64.70			9 149.95
20.0 – 29.9 MW	1 28.00	15 390.25		1 28.00		1 20.00	18 466.25
30.0 – 49.9 MW	3 112.00	12 488.10		2 82.00	1 39.60	1 37.00	19 758.70
50.0 – 74.9 MW	4 245.50	3 177.00	1 54.00	7 452.00			15 928.50
75.0 – 99.9 MW		4 332.00					4 332.00
100 – 199 MW		5 759.47					5 759.47
200 – 499 MW		2 544.00					2 544.00
Totals	18 Totals 440.72	866 3,547.31	30 110.62	25 655.28	4 46.73	37 125.48	980 4,926.13

Key:	
Number of Sites	12
Electrical Capacity, MW	42.67

Table A9. Commercial CHP Installations and Capacity by State and Prime Mover

State	Boiler/Steam Turbine	Combined Cycle	Combustion Turbine	Reciprocating Engine	Other	Totals
AK			2 6.15	4 6.87		6 13.02
AL			1 3.00			1 3.00
AR				2 12.60		2 12.60
AZ			2 1.45	12 4.36		14 5.81
CA	4 110.20	9 281.45	35 318.07	388 138.24	11 2.84	447 850.79
CO		1 33.00	1 76.00	4 1.20		6 110.20
CT	5 26.80	1 56.00	7 45.40	35 4.61		48 132.81
FL	2 109.60	1 27.50	3 17.25	8 21.41		14 175.75
GU				1 0.01		1 0.01
HI		1 64.50		5 0.42		6 64.92
IA				6 5.64		6 5.64
ID	1 20.00					1 20.00
IL	3 49.00		5 27.20	16 24.86		24 101.06
IN	1 40.00		1 2.75	2 2.80	1 0.20	5 45.75
KY				1 0.40		1 0.40
MA		1 64.00	1 22.00	27 10.78	1 0.35	30 97.13
MD	3 74.00					3 74.00
ME	1 1.13			1 0.01		2 1.14
MI	4 143.70		7 68.46	10 7.46		21 219.62
MN	1 4.20		1 5.20	1 0.15		3 9.55
MO	3 53.00		1 15.45	2 4.45		6 72.90
MS			1 4.35			1 4.35
MT				1 0.15		1 0.15

NC	1						1	28.00	
NE					2	0.98			2 0.98
NH	2				2	3.37			4 8.37
NJ	3		12	74.50	90	29.16	1	0.45	106 202.34
NM			2	7.17	5	6.05			7 13.22
NV					1	0.02			1 0.02
NY	10	7	4	130.50	95	79.96			116 1,067.89
OH	1		3	3.28	3	0.88			7 4.93
OK			1	16.30					1 16.30
PA	7	1	4	20.67	15	68.86	2	0.38	29 458.73
RI					5	1.09			5 1.09
SC	3								3 91.00
SD					1	2.70			1 2.70
TN			3	15.40			3	31.80	6 47.20
TX	1	3	5	48.90	10	38.46			19 449.30
UT					3	5.25			3 5.25
VA	1	1			6	15.52			8 175.52
VT					2	0.11			2 0.11
WA					1	3.59			1 3.59
WI	2	1	2	3.85	1	0.03			6 263.63
WV	1				2	3.39			3 65.39
Totals	60	27	104	933.28	770	505.81	19	36.02	980 4,926.13

Key:	
Number of Sites	12
Electrical Capacity, MW	42.67

Table A10. Commercial CHP Installations and Capacity by Ownership and Prime Mover

	3 rd Party	Self	Totals
Boiler/Steam Turbine	26 936.96	34 404.13	60 1,341.10
Combined Cycle	20 1,899.72	7 210.20	27 2,109.92
Combustion Turbine	26 364.82	78 568.46	104 933.28
Reciprocating Engine	502 174.89	268 330.93	770 505.81
Other	13 3.65	6 32.37	19 36.02
Totals	587 3,380.04	393 1,546.09	980 4,926.13

Key:	
Number of Sites	12
Electrical Capacity, MW	42.67

Table A11. Commercial CHP Installations and Capacity by Sales Arrangements and Prime Mover

	No	Yes	Totals
Boiler/Steam Turbine	22 305.31	38 1,035.79	60 1,341.10
Combined Cycle	3 111.20	24 1,998.72	27 2,109.92
Combustion Turbine	66 378.59	38 554.69	104 933.28
Reciprocating Engine	626 260.18	144 245.63	770 505.81
Other	14 28.07	5 7.95	19 36.02
Totals	731 1,083.35	249 3,842.78	980 4,926.13

Key:	
Number of Sites	12
Electrical Capacity, MW	42.67

Table A12. Commercial CHP Installations and Capacity by Prime Mover and Fuel Type

	Coal	Natural Gas	Oil	Waste	Wood	Other	Totals
Boiler/Steam Turbine	17 376.22	9 166.86	8 76.30	19 652.05	4 46.73	3 22.94	60 1,341.10
Combined Cycle	1 64.50	26 2,045.42					27 2,109.92
Combustion Turbine		102 895.48	1 0.80			1 37.00	104 933.28
Reciprocating Engine		717 436.90	21 33.52	6 3.23		26 32.17	770 505.81
Other		12 2.65				7 33.37	19 36.02
Totals	18 440.72	866 3,547.31	30 110.62	25 655.28	4 46.73	37 125.48	980 4,926.13

Key:	
Number of Sites	12
Electrical Capacity, MW	42.67

Table A13. Commercial CHP Installations and Capacity by Size Range and Prime Mover

Size Range	Boiler/ Steam Turbine	Combined Cycle	Combust. Turbine	Recip. Engine	Other	Totals
0 – 999 kW	7 3.23		20 15.38	662 95.09	16 4.22	705 117.93
1.0 – 4.9 MW	15 37.06		42 118.21	83 182.02		140 337.28
5.0 – 9.9 MW	4 24.80	3 22.20	16 97.48	16 95.80	1 7.30	40 247.58
10.0 – 14.9 MW	3 34.00		11 139.37	7 86.60	2 24.50	23 284.47
15.0 – 19.9 MW	7 118.20		2 31.75			9 149.95
20.0 – 29.9 MW	5 119.70	6 170.05	5 130.20	2 46.30		18 466.25
30.0 – 49.9 MW	8 317.10	5 196.70	6 244.90			19 758.70
50.0 – 74.9 MW	11 687.00	4 241.50				15 928.50
75.0 – 99.9 MW		2 176.00	2 156.00			4 332.00
100 – 199 MW		5 759.47				5 759.47
200 – 499 MW		2 544.00				2 544.00
<i>Totals</i>	60	27	104	770	19	980
Totals	1,341.10	2,109.92	933.28	505.81	36.02	4,926.13

Key:	
Number of Sites	12
Electrical Capacity, MW	42.67

Appendix B - CHP Technical Market Potential

Table B-1 Commercial/Institutional CHP Market Potential by Application and State (MW)

Table B-2 Commercial/Institutional CHP Potential by Size and State

Table B-1 - Commercial/Institutional CHP Market Potential by Application and State (MW)

State	MW Potential by Application							
	Hotels/Motels	Nursing Homes	Hospitals	Schools	Colleges & Universities	Commercial Laundries	Car Washes	Health Clubs/Spas
Alabama	57.4	152.9	158.3	231.3	82.0	9.8	4.9	53.1
Alaska	19.7	5.0	27.0	31.4	10.6	0.4	0.0	16.6
Arizona	245.7	115.0	127.8	210.0	78.1	9.4	12.3	52.7
Arkansas	23.6	64.6	60.2	118.4	20.0	4.3	1.5	25.8
California	591.6	286.8	689.8	1,544.9	343.7	50.2	51.1	444.3
Colorado	115.2	97.1	87.5	185.8	72.3	6.4	5.3	76.6
Connecticut	32.4	169.8	115.8	178.5	48.7	6.2	0.7	74.5
Delaware	9.8	22.8	20.0	47.0	17.2	2.1	0.7	8.1
District of Columbia	199.9	19.3	77.9	41.5	52.1	0.7	2.0	21.2
Florida	801.5	527.5	517.2	813.7	172.6	31.2	18.5	221.8
Georgia	238.4	184.1	266.2	527.2	68.1	17.2	11.5	101.1
Hawaii	102.2	7.7	17.3	24.0	13.6	1.6	0.2	8.8
Idaho	41.4	53.8	53.3	52.0	23.8	3.2	2.5	21.2
Illinois	245.8	334.0	392.8	533.1	229.3	17.5	12.6	133.2
Indiana	71.0	155.9	183.8	342.3	91.3	9.3	5.8	60.6
Iowa	37.1	65.5	86.5	153.1	67.6	2.0	1.5	16.9
Kansas	40.5	78.3	104.5	140.6	50.8	5.0	4.3	26.6
Kentucky	35.6	69.4	115.2	218.2	50.1	6.1	1.8	26.0
Louisiana	186.9	109.9	176.2	288.8	49.7	4.7	6.2	60.7
Maine	15.4	31.2	41.3	70.5	24.2	1.1	0.0	17.5
Maryland	93.1	263.5	200.7	274.3	69.7	11.5	5.7	86.6
Massachusetts	107.7	349.8	266.4	343.3	121.5	15.6	1.5	144.4
Michigan	126.6	297.9	330.7	459.2	131.0	16.7	8.4	116.0
Minnesota	49.7	109.8	88.8	321.0	74.0	3.9	2.2	34.1
Mississippi	176.9	70.0	105.9	163.3	55.7	3.4	0.9	31.6
Missouri	116.9	243.7	254.7	253.2	92.5	16.1	9.3	58.8
Montana	21.7	27.6	26.2	35.7	22.8	0.9	0.0	14.1
Nebraska	28.1	48.9	60.4	77.5	31.3	1.4	1.8	11.5
Nevada	747.5	10.0	20.9	72.2	10.6	4.3	0.9	20.7
New Hampshire	31.1	25.8	23.5	76.3	13.6	1.5	0.0	23.0
New Jersey	226.8	345.1	315.1	546.0	109.5	18.5	3.1	150.6
New Mexico	33.2	30.2	38.3	98.0	32.7	1.8	1.1	21.2
New York	359.9	820.4	692.4	1,364.7	260.7	34.4	3.3	256.0
North Carolina	141.9	307.6	326.1	466.0	174.2	17.0	10.4	102.6
North Dakota	9.1	31.7	17.2	31.2	25.5	0.9	0.2	8.3
Ohio	115.7	439.4	376.8	567.8	195.8	24.5	9.7	114.6
Oklahoma	33.0	79.0	131.5	136.9	57.0	5.7	1.1	24.0
Oregon	63.4	63.3	122.0	140.8	94.4	4.7	3.7	76.5
Pennsylvania	134.0	482.8	470.0	704.7	233.7	17.0	5.9	143.8
Rhode Island	10.0	53.5	42.8	39.3	34.7	1.8	0.2	14.8
South Carolina	109.8	135.6	135.8	244.0	57.2	7.8	5.9	43.4
South Dakota	7.7	15.3	17.4	44.0	14.3	0.4	0.9	7.1
Tennessee	70.1	66.0	150.6	281.0	71.3	7.5	0.9	46.3
Texas	349.6	399.7	621.8	1,238.9	351.6	41.8	41.9	219.3
Utah	58.9	32.8	55.8	114.9	47.1	5.7	2.0	40.1
Vermont	26.0	11.9	9.0	45.2	23.8	0.2	0.0	8.1
Virginia	137.7	171.7	231.3	371.2	98.4	11.1	5.9	88.4
Washington	73.8	188.5	155.3	243.0	69.1	7.8	5.4	96.7
West Virginia	33.2	43.1	79.1	67.2	24.3	1.8	0.4	18.7
Wisconsin	75.6	266.5	172.6	287.6	68.8	9.1	0.0	53.0
Wyoming	21.5	10.5	21.3	22.9	15.9	0.7	4.9	10.2
Totals	6,702	7,992	8,879	14,883	4,249	484	281	3,552

Table B-1 (continued) - Commercial/Institutional CHP Market Potential by Application and State (MW)

State	MW Potential by Application							Total Potential (MW)
	Museums	Correctional Facilities	Water Treatment/Sanitary	Extended Service Restaurants	Supermarkets	Refrigerated Warehouses	Office Buildings	
Alabama	6.2	19.9	18.3	45.4	20.5	10.7	223.1	1,132
Alaska	0.4	7.9	5.3	5.1	2.5	3.9	54.9	219
Arizona	10.1	51.2	8.3	92.0	21.3	7.1	338.6	1,443
Arkansas	1.8	15.1	19.0	19.2	7.0	11.2	140.6	548
California	40.9	249.6	118.0	320.7	112.5	113.0	2,359.9	7,475
Colorado	4.6	32.8	14.6	82.9	18.0	11.3	286.3	1,120
Connecticut	4.2	48.9	14.9	25.5	16.4	5.0	217.6	981
Delaware	4.3	11.6	2.8	12.3	3.3	2.8	61.0	236
District of Columbia	27.6	21.1	0.0	36.9	2.4	0.0	87.1	590
Florida	16.2	223.0	57.5	310.6	91.6	29.0	1,151.5	5,339
Georgia	9.8	138.3	19.3	114.1	46.2	45.3	460.1	2,353
Hawaii	4.6	8.9	2.0	15.1	3.1	1.8	67.5	284
Idaho	0.2	7.7	4.7	19.7	7.6	4.9	72.8	376
Illinois	15.5	88.1	34.9	115.4	38.3	28.8	494.2	2,773
Indiana	8.2	49.8	29.7	64.9	23.6	14.4	352.1	1,491
Iowa	1.1	16.0	11.8	11.6	10.8	22.0	159.4	682
Kansas	1.3	27.4	7.9	35.2	9.8	13.6	195.7	768
Kentucky	1.8	37.3	21.3	34.8	14.2	6.9	243.0	901
Louisiana	4.1	44.6	20.3	53.7	20.5	3.4	253.1	1,316
Maine	0.9	8.0	6.0	7.5	5.5	3.2	63.5	300
Maryland	7.4	42.3	7.0	93.3	29.9	5.6	436.6	1,711
Massachusetts	21.9	37.1	36.0	77.8	23.8	19.9	357.5	1,960
Michigan	16.0	96.8	21.6	163.9	46.8	23.4	654.0	2,560
Minnesota	5.7	34.6	7.9	20.8	10.1	14.0	370.1	1,165
Mississippi	0.9	21.9	15.5	24.0	11.3	10.6	145.5	854
Missouri	8.2	42.0	12.4	86.1	21.4	18.0	345.9	1,639
Montana	1.8	5.0	2.3	7.7	4.2	2.3	49.0	226
Nebraska	2.8	15.2	1.4	16.7	8.5	12.7	95.6	428
Nevada	0.9	14.6	3.8	47.3	5.2	1.6	140.6	1,117
New Hampshire	1.4	7.2	3.9	6.3	4.0	0.7	62.2	287
New Jersey	7.1	58.8	54.7	77.4	39.0	36.0	661.5	2,720
New Mexico	4.7	23.0	6.4	17.8	6.8	0.4	89.1	418
New York	34.6	153.6	38.8	160.7	73.7	28.1	1,741.3	6,092
North Carolina	9.6	125.5	14.3	125.0	47.9	18.3	424.0	2,408
North Dakota	1.4	2.7	1.6	5.1	1.8	0.9	41.3	181
Ohio	13.6	80.2	45.5	138.9	47.7	15.8	821.9	3,075
Oklahoma	3.5	29.3	9.1	31.6	13.9	5.3	236.2	818
Oregon	6.8	21.7	9.2	52.3	18.2	16.5	307.4	1,014
Pennsylvania	15.3	121.2	59.9	120.9	56.4	38.3	732.0	3,424
Rhode Island	0.9	5.4	2.0	9.1	2.9	0.2	67.2	289
South Carolina	5.5	51.2	17.3	76.1	26.0	6.0	192.4	1,194
South Dakota	0.9	6.9	1.8	2.6	1.9	2.7	44.6	171
Tennessee	4.2	45.3	20.7	34.7	11.2	17.3	319.7	1,167
Texas	18.3	325.4	73.2	314.7	96.3	51.5	1,469.7	5,829
Utah	4.1	13.3	2.9	21.5	10.2	7.8	115.6	537
Vermont	0.2	14.7	0.4	3.6	2.5	1.1	28.8	179
Virginia	17.7	100.0	15.6	91.4	35.9	17.0	418.1	1,858
Washington	6.7	46.9	19.8	73.4	27.5	54.9	536.1	1,638
West Virginia	2.1	15.3	14.0	17.3	8.7	1.1	88.2	424
Wisconsin	7.4	50.3	13.6	44.0	21.2	24.9	302.3	1,420
Wyoming	1.4	5.9	0.4	6.3	3.0	0.7	29.6	160
Totals	397	2,721	949	3,390	1,184	792	18,614	77,282

Table B-2 Commercial/Institutional CHP Potential by Size and State

State	MW Potential by Size				
	100-500 kW	500-1000 kW	1 - 5 MW	> 5 MW	Total
Alabama	408.9	337.5	299.4	86.5	1,132
Alaska	68.5	57.9	40.4	52.6	219
Arizona	458.1	352.7	402.6	229.7	1,443
Arkansas	263.2	169.5	103.0	12.5	548
California	2,677.2	2,287.3	1,749.9	760.2	7,475
Colorado	414.4	340.2	263.8	101.7	1,120
Connecticut	276.6	311.7	326.0	66.9	981
Delaware	77.5	74.3	68.8	15.2	236
District of Columbia	106.5	95.3	152.3	236.0	590
Florida	1,545.4	1,537.1	1,565.4	691.0	5,339
Georgia	803.4	733.7	549.3	269.0	2,355
Hawaii	86.0	69.5	84.0	44.3	284
Idaho	130.0	91.1	109.9	44.8	376
Illinois	852.4	742.4	877.4	300.4	2,773
Indiana	561.5	424.1	370.0	135.9	1,491
Iowa	302.4	171.4	146.3	61.8	682
Kansas	300.8	223.5	169.0	74.7	768
Kentucky	397.3	264.6	189.5	50.2	901
Louisiana	475.3	362.6	303.8	174.8	1,316
Maine	133.3	77.8	63.8	24.7	300
Maryland	504.0	471.8	506.4	228.8	1,711
Massachusetts	556.3	664.9	583.4	155.4	1,960
Michigan	896.8	694.8	749.3	222.0	2,563
Minnesota	446.8	395.3	242.0	80.6	1,165
Mississippi	286.5	189.6	193.3	184.1	854
Missouri	564.7	462.3	419.8	192.3	1,639
Montana	97.5	62.7	52.0	14.1	226
Nebraska	176.4	123.2	81.9	46.6	428
Nevada	152.4	117.3	274.3	573.0	1,117
New Hampshire	110.4	99.1	52.5	24.7	287
New Jersey	744.9	790.0	822.0	362.7	2,720
New Mexico	187.5	119.6	83.5	27.0	418
New York	1,658.4	1,755.9	1,972.1	705.5	6,092
North Carolina	800.4	719.6	622.1	265.6	2,408
North Dakota	71.2	50.1	36.8	23.0	181
Ohio	1,055.9	914.3	803.9	301.0	3,075
Oklahoma	345.2	221.4	183.0	68.6	818
Oregon	348.8	300.1	233.3	131.9	1,014
Pennsylvania	1,051.4	1,023.2	1,077.3	274.0	3,426
Rhode Island	84.3	81.6	88.4	34.8	289
South Carolina	454.8	337.1	308.8	93.1	1,194
South Dakota	86.8	49.6	30.5	4.0	171
Tennessee	441.3	349.4	281.3	95.0	1,167
Texas	2,031.4	1,691.4	1,464.8	643.5	5,831
Utah	191.9	159.1	109.5	76.8	537
Vermont	63.9	56.7	36.3	21.9	179
Virginia	652.6	546.2	479.4	179.6	1,858
Washington	599.5	482.9	442.9	114.4	1,640
West Virginia	165.1	118.4	103.5	36.5	424
Wisconsin	503.1	394.9	438.0	83.8	1,420
Wyoming	70.0	50.0	27.5	12.4	160
Totals	25,739	22,217	20,638	8,689	77,281

Appendix C - CHP Technology Characterization

Combined heat and power (CHP) technologies produce electricity or mechanical power and recover waste heat for process use. Conventional centralized power systems average less than 33% delivered efficiency for electricity in the U.S.; CHP systems can deliver energy with efficiencies exceeding 80%³, while significantly reducing emissions per delivered MWh. CHP systems can provide cost savings for industrial and commercial users and substantial emissions reductions. This report describes the leading CHP technologies, their efficiency, size, cost to install and maintain, fuels and emission characteristics.

The technologies included in this appendix include diesel engines, natural gas engines, steam turbines, gas turbines, combined cycle units, microturbines and fuel cells. These CHP technologies are commercially available for on-site generation and combined heat and power applications. The power industry is witnessing dramatic changes with utility restructuring and increased customer choice. As a result of these changes, CHP is expected to gain wider acceptance in the market.

Selecting a CHP technology for a specific application depends on many factors, including the amount of power needed, the duty cycle, space constraints, thermal needs, emission regulations, fuel availability, utility prices and interconnection issues. Table C-1 summarizes the characteristics of each CHP technology. The table shows that CHP covers a wide capacity range from 50 kW reciprocating engines to 300 MW gas turbines. Estimated costs per installed kW range from \$500-\$1400/kW.

³ T. Casten, *CHP – Policy Implications for Climate Change and Electric Deregulation*, May 1998, p2.

Table C-1. Comparison of CHP Technologies

	Diesel Engine	Natural Gas Engine	Steam Turbine	Gas Turbine	Micro-turbine	Fuel Cells
Electric Efficiency (LHV)	30-50%	25-45%	15-35%	25-40% (simple) 40-60% (combined)	20-30%	40-70%
Size (MW)	0.05-5	0.05-5	Any	0.5 -200	0.025-0.25	0.2-2
Footprint (sqft/kW)	0.22	0.22-0.31	<0.1	0.02-0.61	0.15-1.5	0.6-4
CHP installed cost (\$/kW)	800-1500	800-1500	800-1000	700-900	500-1300	>3000
O&M Cost (\$/kWh)	0.005-0.008	0.007-0.015	0.004	0.002-0.008	0.002-0.01	0.003-0.015
Availability	90-95%	92-97%	Near 100%	90-98%	90-98%	>95%
Hours between overhauls	25,000-30,000	24,000-60,000	>50,000	30,000-50,000	5,000-40,000	10,000-40,000
Start-up Time	10 sec	10 sec	1 hr-1 day	10 min –1 hr	60 sec	3 hrs-2 days
Fuel pressure (psi)	<5	1-45	n/a	120-500 (may require compressor)	40-100 (may require compressor)	0.5-45
Fuels	diesel and residual oil	natural gas, biogas, propane	all	natural gas, biogas, propane, distillate oil	natural gas, biogas, propane, distillate oil	hydrogen, natural gas, propane
Noise	moderate to high (requires building enclosure)	moderate to high (requires building enclosure)	moderate to high (requires building enclosure)	moderate (enclosure supplied with unit)	moderate (enclosure supplied with unit)	low (no enclosure required)
NO _x Emissions(lb/MWh)	3-33	2.2-28	1.8	0.3-4	0.4-2.2	<0.02
Uses for Heat Recovery	hot water, LP steam, district heating	hot water, LP steam, district heating	LP-HP steam, district heating	direct heat, hot water, LP-HP steam, district heating	direct heat, hot water, LP steam	hot water, LP-HP steam
CHP Output (Btu/kWh)	3,400	1,000-5,000	n/a	3,400-12,000	4,000-15,000	500-3,700
Useable Temp for CHP (F)	180-900	300-500	n/a	500-1,100	400-650	140-700

1. Reciprocating Engines

Introduction

Among the most widely used and most efficient prime movers are reciprocating (or internal combustion) engines. Electric efficiencies of 25-50% make reciprocating engines an economic CHP option in many applications. Several types of reciprocating engines are commercially available, however, two designs are of most significance to stationary power applications and include four cycle- spark-ignited (Otto cycle) and compression-ignited (diesel cycle) engines. They can range in size from small fractional portable gasoline engines to large 50,000 HP diesels for ship propulsion. In addition to CHP applications, diesel engines are widely used to provide standby or emergency power to hospitals, and commercial and industrial facilities for critical power requirements.

Technology Description

The essential mechanical parts of Otto-cycle and diesel engines are the same. Both use a cylindrical combustion chamber in which a close fitting piston travels the length of the cylinder. The piston is connected to a crankshaft which transforms the linear motion of the piston within the cylinder into the rotary motion of the crankshaft. Most engines have multiple cylinders that power a single crankshaft. Both Otto-cycle and diesel four stroke engines complete a power cycle in four strokes of the piston within the cylinder. Strokes include: 1) introduction of air (or air-fuel mixture) into the cylinder, 2) compression with combustion of fuel, 3) acceleration of the piston by the force of combustion (power stroke) and 4) expulsion of combustion products from the cylinder.

The primary difference between Otto and diesel cycles is the method of fuel combustion. An Otto cycle uses a spark plug to ignite a pre-mixed fuel-air mixture introduced to the cylinder. A diesel engine compresses the air introduced in the cylinder to a high pressure, raising its temperature to the ignition temperature of the fuel which is injected at high pressure.

A variation of the diesel is the dual fuel engine. Up to 80-90% of the diesel fuel is substituted with gasoline or natural gas while maintaining power output and achieving substantial emission reductions.

Large modern diesel engines can attain electric efficiencies near 50% and operate on a variety of fuels including diesel fuel, heavy fuel oil or crude oil. Diesel engines maintain higher part load efficiencies than an Otto cycle because of leaner fuel-air ratios at reduced load.

Design Characteristics

The features that have made reciprocating engines a leading prime mover for CHP include:

Economical size range:	Reciprocating engines are available in sizes that match the electric demand of many end-users (institutional, commercial and industrial).
Fast start-up:	Fast start-up allows timely resumption of the system following a maintenance procedure. In peaking or emergency power applications, reciprocating engines can quickly supply electricity on demand.
Black-start capability:	In the event of a electric utility outage, reciprocating engines can be started with minimal auxiliary power requirements, generally only batteries are required.
Excellent availability:	Reciprocating engines have typically demonstrated availability in excess of 95%.
Good part load operation:	In electric load following applications, the high part load efficiency of reciprocating engines maintain economical operation.
Reliable and long life:	Reciprocating engines, particularly diesel and industrial block engines have provided many years of satisfactory service given proper maintenance.

Performance Characteristics

Efficiency

Reciprocating engines have electric efficiencies of 25-50% (LHV) and are among the most efficient of any commercially available prime mover. The smaller stoichiometric engines that require 3-way catalyst after-treatment operate at the lower end of the efficiency scale while the larger diesel and lean burn natural gas engines operate at the higher end of the efficiency range.

Capital Cost

CHP projects using reciprocating engines are typically installed between \$800-\$1500/kW. The high end of this range is typical for small capacity projects that are sensitive to other costs associated with constructing a facility, such as fuel supply, engine enclosures, engineering costs, and permitting fees.

Availability

Reciprocating engines have proven performance and reliability. With proper maintenance and a good preventative maintenance program, availability is over 95%. Improper maintenance can have major impacts on availability and reliability.

Maintenance

Engine maintenance is comprised of routine inspections/adjustments and periodic replacement of engine oil, coolant and spark plugs every 500-2,000 hours. An oil analysis is an excellent method to determine the condition of engine wear. The time interval for overhauls is recommended by the manufacturer but is generally between 12,000-15,000 hours of operation for a top-end overhaul and 24,000-30,000 for a major overhaul. A top-end overhaul entails a cylinder head and turbo-charger rebuild. A major overhaul involves piston/ring replacement and crankshaft bearings and seals. Typical maintenance costs including an allowance for overhauls is 0.01 - 0.015\$/kWhr.

Heat Recovery

Energy in the fuel is released during combustion and is converted to shaft work and heat. Shaft work drives the generator while heat is liberated from the engine through coolant, exhaust gas and surface radiation. Approximately 60-70% of the total energy input is converted to heat that can be recovered from the engine exhaust and jacket coolant, while smaller amounts are also available from the lube oil cooler and the turbocharger's intercooler and aftercooler (if so equipped). Steam or hot water can be generated from recovered heat that is typically used for space heating, reheat, domestic hot water and absorption cooling.

Heat in the engine jacket coolant accounts for up to 30% of the energy input and is capable of producing 200°F hot water. Some engines, such as those with high pressure or ebullient cooling systems, can operate with water jacket temperatures up to 265°.

Engine exhaust heat is 10-30% of the fuel input energy. Exhaust temperatures of 850°-1200°F are typical. Only a portion of the exhaust heat can be recovered since exhaust gas temperatures are generally kept above condensation thresholds. Most heat recovery units are designed for a 300°-350°F exhaust outlet temperature to avoid the corrosive effects of condensation in the exhaust piping. Exhaust heat is typically used to generate hot water to about 230°F or low-pressure steam (15 psig).

By recovering heat in the jacket water and exhaust, approximately 70-80% of the fuel's energy can be effectively utilized as shown in Figure C-1 for a typical spark-ignited engine.

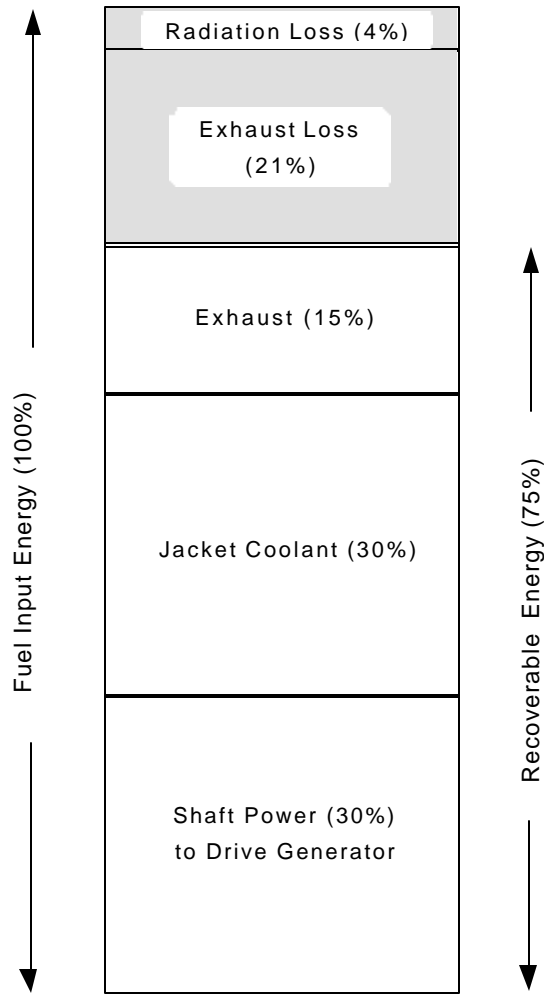

Figure C.1 Energy Balance for a Reciprocating Engine

Closed-Loop Hot Water Cooling Systems

The most common method of recovering engine heat is the closed-loop cooling system as shown in Figure C-2. These systems are designed to cool the engine by forced circulation of a coolant through engine passages and an external heat exchanger. An excess heat exchanger transfers engine heat to a cooling tower or radiator when there is excess heat generated. Closed-loop water cooling systems can operate at coolant temperatures between 190°-250°F.

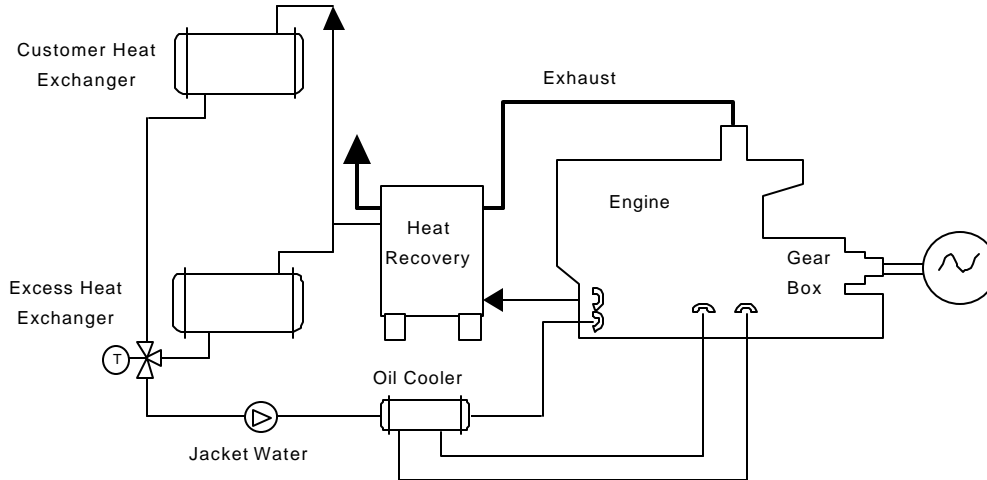

Figure C.2. Closed-Loop Heat Recovery System

Ebullient Cooling Systems

Ebullient cooling systems cool the engine by natural circulation of a boiling coolant through the engine. This type of cooling system is typically used in conjunction with exhaust heat recovery for production of low-pressure steam. Cooling water is introduced at the bottom of the engine where the transferred heat begins to boil the coolant generating two-phase flow. The formation of bubbles lowers the density of the coolant, causing a natural circulation to the top of the engine.

The coolant at the engine outlet is maintained at saturated steam conditions and is usually limited to 250°F and a maximum of 15 psig. Inlet cooling water is also near saturation conditions and is generally 2°- 3°F below the outlet temperature. The uniform temperature throughout the coolant circuit extends engine life, contributes to improved combustion efficiencies and reduces friction in the engine.

Emissions

The two primary methods of lowering emissions in Otto cycle engines is lean burn (combustion control) and rich burn with a catalytic after-treatment.

Lean burn engine technology was developed during the 1980's in response to the need for cleaner burning engines. Most lean burn engines use turbocharging to supply excess air to the engine and produce lean fuel-air ratios. Lean burn engines consume 50-100% excess air (above stoichiometric) to reduce temperatures in the combustion chamber and limit creation of nitrogen oxides (NO_x), carbon dioxide (CO) and non-methane hydrocarbons (NMHC.) The typical NO_x emission rate for lean burn engines is between 0.5–2.0 grams/hphr. Emission levels can be reduced to less than 0.15gm/hphr with selective catalytic reduction (SCR) where ammonia is injected into the exhaust gas in the presence

of a catalyst. SCR adds a significant cost burden to the installation cost and increases the O&M on the engine. This approach is typically used on large capacity engines.

Catalytic converters are used with rich burn (i.e. stoichiometric) Otto cycles. A reducing catalyst converts NO_x to N_2 and oxidizes some of the CO to CO_2 . A catalytic converter can contain both reducing and oxidizing catalytic material in a single bed. Electronic fuel–air ratio controls are typically needed to hold individual emission rates to within a very close tolerance. Also referred to as a three-way catalyst, hydrocarbon, NO_x and CO are simultaneously controlled. Typical NO_x emission rates for rich burn engines are approximately 9 grams/hphr. Catalytic converters have proven to be the most effective after treatment of exhaust gas with control efficiencies of 90-99%+, reducing NO_x emissions to 0.15gm/hphr. A stoichiometric engine with a catalytic convertor operates with an efficiency of approximately 30%. Maintenance costs can increase by 25% for catalyst replacement.

Diesel engines operate at much higher air-fuel ratios than Otto cycle engines. The high excess air (lean condition) causes relatively low exhaust temperatures such that conventional catalytic converters for NO_x reduction are not effective. Lean NO_x catalytic converters are currently under development. Some diesel applications employ SCR to reduce emissions.

A major emission impact of a diesel engine is particulates. Particulate traps physically capture fine particulate matter generated by the combustion of diesel fuel and are typically 90% effective. Some filters are coated with a catalyst that must be regenerated for proper operation and long life.

Applications

Reciprocating engines are typically used in CHP applications where there is a substantial hot water or low pressure steam demand. When cooling is required, the thermal output of a reciprocating engine can be used in a single-effect absorption chiller. Reciprocating engines are available in a broad size range of approximately 50kW to 5,000kW suitable for a wide variety of commercial, institutional and small industrial facilities. Reciprocating engines are frequently used in load following applications where engine power output is regulated based on the electric demand of the facility. Thermal output varies accordingly. Thermal balance is achieved through supplemental heat sources such as boilers.

Technology Advancements

Advances in electronics, controls and remote monitoring capability should increase the reliability and availability of engines. Maintenance intervals are being extended through development of longer life spark plugs, improved air and fuel filters, synthetic lubricating oil and larger engine oil sumps.

Reciprocating engines have been commercially available for decades. A global network of manufacturers, dealers and distributors is well established.

2. Steam Turbines

Introduction

Steam turbines are one of the most versatile and oldest prime mover technologies used to drive a generator or mechanical machinery. Steam turbines are widely used for CHP applications in the U.S. and Europe where special designs have been developed to maximize efficient steam utilization.

Most of the electricity in the United States is generated by conventional steam turbine power plants. The capacity of steam turbines can range from a fractional horsepower to more than 1,300 MW for large utility power plants.

A steam turbine is captive to a separate heat source and does not directly convert a fuel source to electric energy. Steam turbines require a source of high pressure steam that is produced in a boiler or heat recovery steam generator (HRSG). Boiler fuels can include fossil fuels such as coal, oil and natural gas or renewable fuels like wood or municipal waste.

Steam turbines offer a wide array of designs and complexity to match the desired application and/or performance specifications. In utility applications, maximizing efficiency of the power plant is crucial for economic reasons. Steam turbines for utility service may have several pressure casings and elaborate design features. For industrial applications, steam turbines are generally of single casing design, single or multi-staged and less complicated for reliability and cost reasons. CHP can be adapted to both utility and industrial steam turbine designs.

Technology Description

The thermodynamic cycle for the steam turbine is the Rankine cycle. The cycle is the basis for conventional power generating stations and consists of a heat source (boiler) that converts water to high pressure steam. The steam flows through the turbine to produce power. The steam exiting the turbine is condensed and returned to the boiler to repeat the process.

A steam turbine consists of a stationary set of blades (called nozzles) and a moving set of adjacent blades (called buckets or rotor blades) installed within a casing. The two sets of blades work together such that the steam turns the shaft of the turbine and the connected load. A steam turbine converts pressure energy into velocity energy as it passes through the blades.

The primary type of turbine used for central power generation is the *condensing* turbine. Steam exhausts from the turbine at sub-atmospheric pressures, maximizing the heat extracted from the steam to produce useful work.

Steam turbines used for CHP can be classified into two main types:

The *non-condensing turbine* (also referred to as a back-pressure turbine) exhausts steam at a pressure suitable for a downstream process requirement. The term refers to turbines that exhaust steam at atmospheric pressures and above. The discharge pressure is established by the specific CHP application.

The *extraction turbine* has opening(s) in its casing for extraction of steam either for process or feedwater heating. The extraction pressure may or may not be automatically regulated depending on the turbine design. Regulated extraction permits more steam to flow through the turbine to generate additional electricity during periods of low thermal demand by the CHP system. In utility type steam turbines, there may be several extraction points each at a different pressure.

Design Characteristics

- | | |
|-----------------------|--|
| Custom design: | Steam turbines can be designed to match CHP design pressure and temperature requirements. The steam turbine can be designed to maximize electric efficiency while providing the desired thermal output. |
| High thermal quality: | Steam turbines are capable of operating over the broadest available steam pressure range from subatmospheric to supercritical and can be custom designed to deliver the thermal requirements of the CHP application. |
| Fuel flexibility: | Steam turbines offer the best fuel flexibility using a variety of fuel sources including nuclear, coal, oil, natural gas, wood and waste products. |

Performance Characteristics

Efficiency

Modern large condensing steam turbine plants have efficiencies approaching 40-45%, however, efficiencies of smaller industrial or backpressure turbines can range from 15-35%.

Capital Cost

Boiler/ steam turbines installation costs are between \$800-\$1000/kW or greater depending on environmental requirements. The incremental cost of adding a steam turbine to an existing boiler system or to a combined cycle plant is approximately \$400-\$800/kW.

Availability

A steam turbine is generally considered to have 99%+ availability with longer than a year between shutdowns for maintenance and inspections. This high level of availability applies only for the steam turbine and does not include the heat source.

Maintenance

A maintenance issue with steam turbines is solids carry over from the boiler that deposit on turbine nozzles and degrades power output. The oil lubrication system must be clean and at the correct operating temperature and level to maintain proper performance. Other items include inspecting auxiliaries such as lubricating-oil pumps, coolers and oil strainers and check safety devices such as the operation of overspeed trips. Steam turbine maintenance costs are typically less than \$0.004 per kWh.

Heat Recovery

Heat recovery methods from a steam turbine use exhaust or extraction steam. Heat recovery from a steam turbine is somewhat misleading since waste heat is generally associated with the heat source, in this case a boiler either with an economizer or air preheater.

A steam turbine can be defined as a heat recovery device. Producing electricity in a steam turbine from the exhaust heat of a gas turbine (combined cycle) is a form of heat recovery.

The amount and quality of the recovered heat is a function of the entering steam conditions and the design of the steam turbine. Exhaust steam from the turbine can be used directly in a process or for district heating. Or it can be converted to other forms of thermal energy including hot water or chilled water. Steam discharged or extracted from a steam turbine can be used in a single or double-effect absorption chiller. A steam turbine can also be used as a mechanical drive for a centrifugal chiller.

Emissions

Emissions associated with a steam turbine are dependent on the source of the steam. Steam turbines can be used with a boiler firing a large variety of fuel sources or it can be used with a gas turbine in a combined cycle. Boiler emissions can vary depending on

environmental regulations. Large boilers can use SCR to reduce NO_x emissions to single digit levels.

Applications

Steam Turbines for Industrial and CHP Applications

In industrial applications, steam turbines may drive an electric generator or equipment such as boiler feedwater pumps, process pumps, air compressors and refrigeration chillers. Turbines as industrial drivers are almost always a single casing machine, either single stage or multistage, condensing or non-condensing depending on steam conditions and the value of the steam. Steam turbines can operate at a single speed to drive an electric generator or operate over a speed range to drive a refrigeration compressor.

For non-condensing applications, steam is exhausted from the turbine at a pressure and temperature sufficient for the CHP heating application. Back pressure turbines can operate over a wide pressure range depending on the process requirements and exhaust steam at typically between 5 psig to 150 psig. Back pressure turbines are less efficient than condensing turbines, however, they are less expensive and do not require a surface condenser.

Technology Advancements

Steam turbines have been commercially available for decades. Advancements will more likely occur in gas turbine technology.

3. Combustion Turbines and Combined Cycles

Introduction

Over the last two decades, the combustion or gas turbine has seen tremendous development and market expansion. Whereas gas turbines represented only 20% of the power generation market twenty years ago, they now claim approximately 40% of new capacity additions. Gas turbines have been long used by utilities for peaking capacity, however, with changes in the power industry and increased efficiency, the gas turbine is now being used for base load power. Much of this growth can be accredited to large (>50 MW) combined cycle plants that exhibit low capital cost (less than \$550/kW) and high thermal efficiency. Manufacturers are offering new and larger capacity machines that operate at higher efficiencies. Some forecasts predict that gas turbines may furnish more than 80% of all new U.S. generation capacity in coming decades.

Gas turbine development accelerated in the 1930's as a means of propulsion for jet aircraft. It was not until the early 1980's that the efficiency and reliability of gas turbines

had progressed sufficiently to be widely adopted for stationary power applications. Gas turbines range in size from 30 kW (microturbines) to 250 MW (industrial frames).

Technology Description

The thermodynamic cycle associated with the majority of gas turbine systems is the Brayton cycle, that passes atmospheric air, the working fluid, through the turbine only once. The thermodynamic steps of the Brayton cycle include compression of atmospheric air, introduction and ignition of fuel, and expansion of the heated combustion gases through the gas producing and power turbines. The developed power is used to drive the compressor and the electric generator. Primary components of a gas turbine are shown in Figure C-3.

Figure C-3. Components of a Gas Turbine

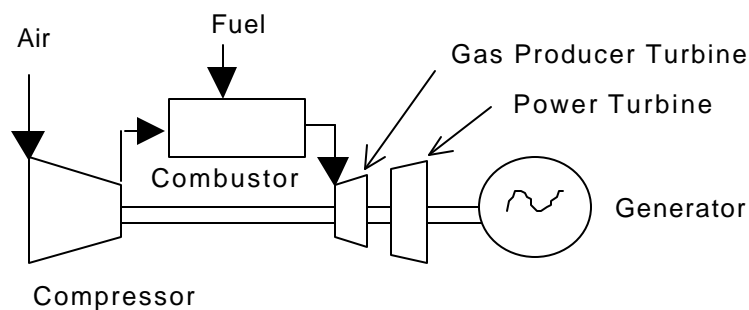

Aeroderivative gas turbines for stationary power are adapted from their jet engine counterpart. These turbines are light weight and thermally efficient, however, are limited in capacity. The largest aeroderivatives are approximately 40 MW in capacity today. Many aeroderivative gas turbines for stationary use operate with compression ratios up to 30:1 requiring an external fuel gas compressor. With advanced system developments, aeroderivatives are approaching 45% simple cycle efficiencies.

Industrial or frame gas turbines are available between 1 MW to 250 MW. They are more rugged, can operate longer between overhauls, and are more suited for continuous base-load operation. However, they are less efficient and much heavier than the aeroderivative. Industrial gas turbines generally have more modest compression ratios up to 16:1 and often do not require an external compressor. Industrial gas turbines are approaching simple cycle efficiencies of approximately 40% and in combined cycles are approaching 60%.

Small industrial gas turbines are being successfully used in industry for on-site power generation and as mechanical drivers. Turbine sizes are typically between 1–10 MW for these applications. Small gas turbines drive compressors along natural gas pipelines for cross country transport. In the petroleum industry they drive gas compressors to maintain well pressures. In the steel industry they drive air compressors used for blast furnaces.

With the coming competitive electricity market, many experts believe that installation of small industrial gas turbines will proliferate as a cost effective alternative to grid power.

Design Characteristics

- Quality thermal output: Gas turbines produce a high quality thermal output suitable for most CHP applications.
- Cost effectiveness: Gas turbines are among the lowest cost power generation technologies on a \$/kW basis, especially in combined cycle.
- Fuel flexibility: Gas turbines operate on natural gas, synthetic gas and fuel oils. Plants are often designed to operate on gaseous fuel with a stored liquid fuel for backup.
- Reliable and long life: Modern gas turbines have proven to be reliable power generation devices, given proper maintenance.
- Economical size range: Gas turbines are available in sizes that match the electric demand of many end-users (institutional, commercial and industrial).

Performance Characteristics

Efficiency

The thermal efficiency of the Brayton cycle is a function of pressure ratio, ambient air temperature, turbine inlet temperature, the efficiency of the compressor and turbine elements and any performance enhancements (i.e. recuperation, reheat, or combined cycle). Efficiency generally increases for higher power outputs and aeroderivative designs. Simple cycle efficiencies can vary between 25-40% lower heating value (LHV). Next generation combined cycles are being advertised with electric efficiencies approaching 60%.

Capital Cost

The capital cost of a gas turbine power plant on a kW basis (\$/kW) can vary significantly depending on the capacity of the facility. Typical estimates vary between \$300-\$900/kW. The lower end applies to large industrial frame turbines in combined cycle.

Availability

Estimated availability of gas turbines operating on clean gaseous fuels like natural gas is in excess of 95%. Use of distillate fuels and other fuels with contaminants require more frequent shutdowns for preventative maintenance that reduce availability.

Maintenance

Although gas turbines can be cycled, maintenance costs can triple for a turbine that is cycled every hour versus a turbine that is operated for intervals of 1000 hours. Operating the turbine over the rated design capacity for significant time periods will also dramatically increase the number of hot path inspections and overhauls. Maintenance costs of a turbine operating on fuel oil can be approximately three times that as compared to natural gas. Typical maintenance costs for a gas turbine fired by natural gas is 0.003-0.005 \$/kWh.

Figure C-4 Heat Recovery from a Gas Turbine System

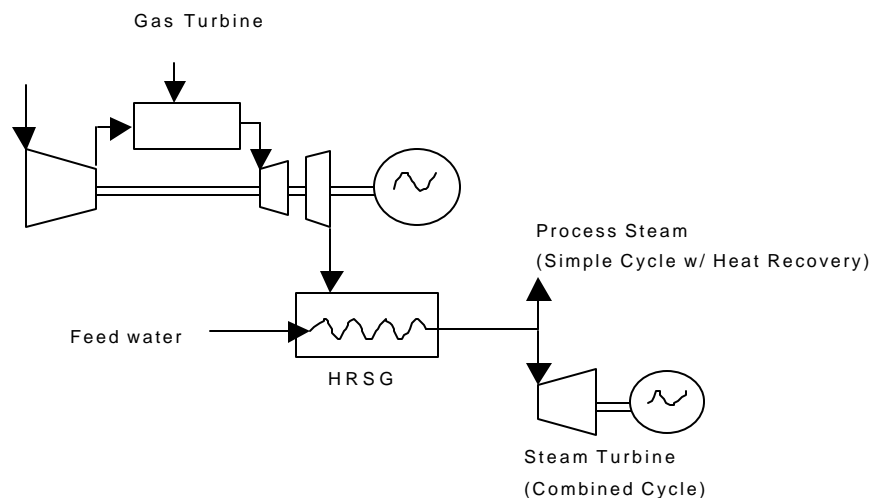

Heat Recovery

The simple cycle gas turbine is the least efficient arrangement since there is no recovery of heat in the exhaust gas. Hot exhaust gas can be used directly in a process or by adding a heat recovery steam generator (HRSG), exhaust heat can generate steam or hot water. An important advantage of CHP using gas turbines is the high quality waste heat available in the exhaust gas. The high temperature exhaust gas is suitable for generating high-pressure steam that is used frequently for industrial processes.

For larger gas turbine installations, combined cycles become economical, achieving approximately 60% electric generation efficiencies using the most advanced utility-class gas turbines. The heat recovery options available from a steam turbine used in the combined cycle can be implemented to further improve the overall system efficiency (as discussed previously.)

Since gas turbine exhaust is oxygen rich, it can support additional combustion through supplementary firing. A duct burner can be fitted within the HRSG to increase the gas temperature and attain overall efficiencies of 90% and greater.

Combined Cycle Power Plants

The trend in power plant design is the combined cycle that incorporates a steam turbine in a bottoming cycle with a gas turbine. Steam generated in the heat recovery steam generator (HRSG) of the gas turbine is used to drive a steam turbine to yield additional electricity and improve cycle efficiency. The steam turbine is usually an extraction-condensing type and can be designed for CHP applications.

Emissions

The dominant NO_x control technologies for gas turbines include water/steam injection and lean pre-mix (combustion control) and selective catalytic reduction (post combustion control). Without any controls, gas turbines produce levels of NO_x between 75-200 ppmv. By injecting water or steam into the combustor, NO_x emissions can be reduced to approximately 42 ppmv with water and 25 ppmv with steam. NO_x emissions from distillate-fired turbines can be reduced to about 42-75 ppmv. Water or steam injection requires very purified water to minimize the effects of water-induced corrosion of turbine components.

Lean pre-mix (dry low NO_x) is a combustion modification where a lean mixture of natural gas and air are pre-mixed prior to entering the combustion section of the gas turbine. Pre-mixing avoids “hot spots” in the combustor where NO_x forms. Turbine manufacturers have achieved NO_x emissions of 9-42 ppmv using this technology. This technology is still being developed and early designs have caused turbine damage due to “flashback”. Elevated noise levels have also been encountered.

Selective catalytic reduction (SCR) is a post combustion treatment of the turbine’s exhaust gas in which ammonia is reacted with NO_x in the presence of a catalyst to produce nitrogen and water. SCR is approximately 80-90% effective in the reduction of upstream NO_x emission levels. Assuming a turbine has NO_x emissions of 25 ppm, SCR can further reduce emissions to 3-5 ppm. SCR is used in series with water/steam injection or lean pre-mix to produce single-digit emission levels. SCR requires an upstream heat recovery device to temper the temperature of the exhaust gas in contact with the catalyst. SCR requires on-site storage of ammonia, a hazardous chemical. In addition ammonia can “slip” through the process unreacted that contributes to air pollution. SCR systems are expensive and significantly impact the economic feasibility of smaller gas turbine projects.

Applications

Gas turbines are a cost effective CHP alternative for commercial and industrial end-users with a base load electric demand greater than about 5 MW. Although gas turbines can operate satisfactorily at part load, they perform best at full power in base load operation. Gas turbines are frequently used in district steam heating systems since their high quality thermal output can be used for most medium pressure steam systems.

Gas turbines for CHP can be in either a simple cycle or a combined cycle configuration. Simple cycle applications are most prevalent in smaller installations typically less than 25 MW. Waste heat is recovered in a HRSG to generate high or low pressure steam or hot water. The thermal product can be used directly or converted to chilled water with single or double effect absorption chillers.

Technology Advancements

Advancements in blade design, cooling techniques and combustion modifications including lean premix (dry low NOx) and catalytic combustion are under development to achieve higher thermal efficiencies and single digit emission levels without post combustion treatment. Gas turbine manufacturers have been commercializing their products for decades. A global network of manufacturers, dealers and distributors is well established

4. Microturbines

Introduction

A new class of small gas turbines called microturbines is emerging for the distributed resource market. Several manufacturers are developing competing engines in the 25-250 kW range, however, multiple units can be integrated to produce higher electrical output while providing additional reliability. Most manufacturers are pursuing a single shaft design wherein the compressor, turbine and permanent-magnet generator are mounted on a single shaft supported on lubrication-free air bearings. These turbines operate at speeds of up to 120,000 rpm and are powered by natural gas, gasoline, diesel, and alcohol. The dual shaft design incorporates a power turbine and gear for mechanical drive applications and operate up to speeds of 40,000 rpm. Microturbines are a relatively new entry in the CHP industry and therefore many of the performance characteristics are estimates based on demonstration projects and laboratory testing.

Technology Description

The operating theory of the microturbine is similar to the gas turbine, except that most designs incorporate a recuperator to recover part of the exhaust heat for preheating the combustion air. Air is drawn through a compressor section, mixed with fuel and ignited to power the turbine section and the generator. The high frequency power that is generated is converted to grid compatible 60HZ through power conditioning electronics. For single shaft machines, a standard induction or synchronous generator can be used without any power conditioning electronics.

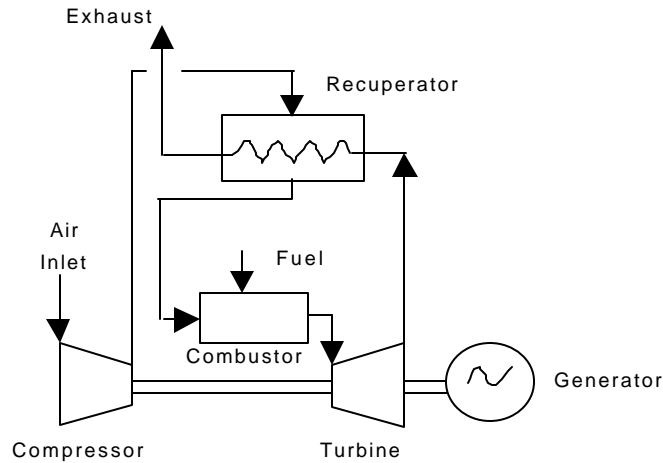

Figure C-5. Schematic of a Recuperated Microturbine

Design Characteristics

- Compact: Their compact and lightweight design makes microturbines an attractive option for many light commercial/ industrial applications.
- Right-sized: Microturbine capacity is right sized for many customers with relatively high electric costs.
- Lower noise: Microturbines promise lower noise levels and can be located adjacent to occupied areas.

Performance Characteristics

Efficiency

Most designs offer a recuperator to maintain high efficiency while operating at combustion temperatures below NO_x formation levels. With recuperation, efficiency is currently in the 20%-30% LHV range.

Capital Cost

Installed prices of \$500-1000/kW for CHP applications is estimated when microturbines are mass produced.

Availability

Although field experience is limited, manufacturers claim that availability will be similar to other competing distributed resource technologies, i.e. in the 90->95% range.

Maintenance

Microturbines have substantially fewer moving parts than engines. The single shaft design with air bearings will not require lubricating oil or water, so maintenance costs should be below conventional gas turbines. Microturbines that use lubricating oil should not require frequent oil changes since the oil is isolated from combustion products. Only an annual scheduled maintenance interval is planned for microturbines. Maintenance costs are being estimated at 0.006-0.01\$/kW.

Heat Recovery

Hot exhaust gas from the turbine section is available for CHP applications. As discussed previously, most designs incorporate a recuperator that limits the amount of heat available for CHP. Recovered heat can be used for hot water heating or low pressure steam applications.

Emissions

NO_x emissions are targeted below 9 ppm using lean pre-mix technology without any post combustion treatment.

Applications

Markets for the microturbine include commercial and light industrial facilities. Since these customers often pay more for electricity than larger end-users, microturbines may offer these customers a cost effective alternative to the grid. Their relatively modest heat output may be ideally matched to customers with low pressure steam or hot water requirements. Manufacturers will target several electric generation applications, including standby power, peak shaving and base loaded operation with and without heat recovery.

One manufacturer is offering a two shaft turbine that can drive refrigeration chillers (100-350 tons), air compressors and other prime movers. The system also includes an optional heat recovery package for hot water and steam applications.

Technology Advancements

Microturbines are being developed in the near term to achieve thermal efficiencies of 30% and NO_x emissions less than 10 ppm. It is expected that performance and maintenance requirements will vary among the initial offerings. Longer term goals are to achieve thermal efficiencies between 35-50% and NO_x emissions between 2-3 ppm through the use of ceramic components, improved aerodynamic and recuperator designs and catalytic combustion.

Manufacturers are currently releasing prototype systems for demonstration and testing. Commercialization is planned by year 2000 with significant cost reductions expected as manufacturing volume increases.

5. Fuel Cells

Introduction

Fuel cells offer the potential for clean, quiet, and very efficient power generation, benefits that have driven their development in the past two decades. Fuel cells offer the ability to operate at electrical efficiencies of 40-60% (LHV) and up to 85% in CHP. Development of fuel cells for commercial use began in earnest in the 1970's for stationary power and transportation applications.

Although several fuel cell designs are under development, only the phosphoric acid fuel cell (PAFC) is commercially available. The price of the most competitive PAFC is still around \$3000/kW which is still too high for most industrial and commercial applications. The fuel cell requires continued research and development before it becomes a serious contender in the CHP market.

Technology Description

Fuel cells are similar to batteries in that they both produce a direct current (DC) through an electrochemical process without direct combustion of a fuel source. However, whereas a battery delivers power from a finite amount of stored energy, fuel cells can operate indefinitely provided that a fuel source is continuously supplied. Two electrodes (a cathode and anode) pass charged ions in an electrolyte to generate electricity and heat. A catalyst is used to enhance the process. Individual fuel cells produce between 0.5-0.9 volts of DC electricity. Fuel cells are combined into "stacks" like a battery to obtain usable voltage and power output.

A fuel cell consists of several major components including a fuel reformer to generate hydrogen-rich gas, a power section where the electrochemical process occurs and a power conditioner to convert the direct current (DC) generated in the fuel cell into alternating current (AC). Fuel reforming "frees" the hydrogen in the fuel and removes other contaminants that would otherwise poison the catalytic electrodes. Fuel processing is usually performed at the point of use eliminating storage of the hydrogen-rich mixture. Depending on the operating temperature of the fuel cell, fuel reforming can occur external or internal to the cell.

The general design of most fuel cells is similar except for the type of electrolyte used. The five main types of fuel cells are defined by their electrolyte and include alkaline, proton exchange membrane (PEMFC), phosphoric acid (PAFC), molten carbonate (MCFC) and solid oxide (SOFC) fuel cells. A comparison of fuel cell types is presented in Table C-2.

Alkaline fuel cells which are very efficient and have been used successfully in the space program, require very pure hydrogen that is expensive to produce and for this reason are not considered major contenders for the stationary power market.

Table C-2: Comparison of Fuel Cell Types

	Alkaline (AFC)	Proton Exchange Membrane (PEM)	Phosphoric Acid (PAFC)	Molten Carbonate (MCFC)	Solid Oxide (SOFC)
Electrolyte	Alkaline lye	Perfluorated sulphonated polymer	Stabilized phosphoric acid	Molten carbonate solution	Ceramic solid electrolyte
Typical Unit Sizes (kW)	<<100	0.1-500	5-200 (plants up to 5,000)	800-2000 (plants up to 100,000)	2.5-100,000
Electric Efficiency	Up to 70%	Up to 50%	40-45%	50-57%	45-50%
Installed Cost (\$/kW)		4,000	3,000-3,500	800-2,000	1,300-2,000
Commercial Availability	Not for CHP	R&D	Yes	R&D	R&D
Power Density lbs/kW ft ³ /kW		8-10 ~0.2	~25 0.4	~60 ~1	~40 ~1
Heat Rejection (Btu/kWh)		1640 @ 0.8 V	1880 @0.74V	850 @0.8V	1780 @0.6V
Electric/ Thermal Energy		~ 1	~ 1	Up to 1.5	Up to 1.5
Oxidation Media	Oxygen	Oxygen from Air	Oxygen from Air	Oxygen from Air	Oxygen from Air
Cooling Medium		Water	Boiling Water	Excess Air	Excess Air
Fuel	H ₂	H ₂ and reformed H ₂	H ₂ reformed from natural gas	H ₂ and CO reformed from natural gas or coal gas	H ₂ and CO reformed from natural gas or coal gas
Operating Temp (F)	160-210	120-210	320-410	1250	1500-1800
Operating Pressure (psig)		14.7-74	14.7-118	14.7-44	14.7->150
Applications	Space and military (today)	Stationary power (1997-2000) Bus, railroad, automotive propulsion (2000-2010)	Stationary power (1998) Railroad propulsion (1999)	Stationary power (2000->2005)	Stationary power and railroad propulsion (1998->2005)

The PAFC represents the most mature technology and is commercially available today, having been installed in over 80 locations in the U.S., Europe and Japan.

The MCFC which is currently being demonstrated at several sites operates at higher temperature and is more efficient than the commercially available PAFC with efficiencies up to 55% (LHV) estimated. The high exhaust temperature of a MCFC can generate additional electricity in a steam turbine or in a gas turbine combined cycle. The MCFC is expected to target 1-20 MW stationary power applications and should be well suited for industrial CHP.

Many experts believe that the SOFC will be the dominant technology for stationary power applications. The SOFC offers the reliability of all-solid ceramic construction and is expected to have an electric efficiency of up to 50% (LHV). The high exhaust temperature of a SOFC can generate additional electricity in a steam turbine or in a gas turbine combined cycle. Hybrid systems using gas turbines or microturbines could increase electric efficiencies to 60%.

The PEMFC is of particular interest to the automotive industry as a future power plant for electric vehicles. Much of the current development effort is to introduce a PEMFC for the stationary power market as an intermediate step towards small and cost effective units for automobiles and buses. The PEMFC has very high power densities and can start-up quickly and meet varying demand.

Design Characteristics

Emissions:	Installation of PAFC has been exempted from air quality permits in some of the strictest districts in the country including South Coast Air Quality Management District in the Los Angeles basin.
Quiet operation:	Much of the appeal of the fuel cell is its quiet operation so that siting and special enclosures are of minimal concern.
Commercial use:	The 200kW PAFC is ideally suited to typical commercial installations.
Thermal quality:	The quality of the thermal product depends on the type of electrolyte. The commercially available PAFC operates at lower temperatures and therefore produces low pressure steam or hot water as a byproduct.

Performance Characteristics

Efficiency

The electric efficiency of fuel cells can be dramatically higher than combustion-based power plants. The current efficiency of PAFC is 40% with a target of 40-60% (LHV) estimated. With the recovery of the thermal byproduct, overall fuel utilization could approach 85%. Fuel cells retain their efficiency at part load.

Capital Cost

The capital cost of fuel cells is currently much higher than competing distributed resources. The commercial PAFC currently costs approximately \$3,000/kW. Fuel cell prices are expected to drop to \$500-\$1500/kW in the next decade with further advancements and increased manufacturing volumes. Substantial cost reductions in the stationary power market are expected from advancements in fuel cells used for transportation.

Availability

Theoretically, fuel cells should have higher availability and reliability than gas turbines or reciprocating engines since they have fewer moving parts. PAFC have run continuously for more than 5,500 hours which is comparable to other power plants. Limited test results for PAFC have demonstrated availability at 96% and 2500 hours between forced outages.

Maintenance

The electrodes within a fuel cell that comprise the “stack” degrade over time reducing the efficiency of the unit. Fuel cells are designed such that the “stack” can be removed. It is estimated that “stack” replacement is required between four and six years when the fuel cell is operated under continuous conditions. The maintenance cost for PAFC (200 kW) including an allowance for periodic stack replacements has been in the range of \$0.02-\$5 kWh. Improvements should bring the cost down to \$0.015/kWhr over the twenty year life of the unit.

Heat Recovery

Significant heat is released in a fuel cell during electrical generation. The PAFC and PEMFC operate at lower temperatures and produce lower grades of waste heat generally suitable for commercial and industrial CHP applications. The MCFC and SOFC operate at much higher temperatures and produce heat that is sufficient to generate additional electricity with a steam turbine or a microturbine hybrid gas turbine combined cycle.

Emissions

Fuel cells have little environmental impact.

Applications

The type of fuel cell determines the temperature of the heat liberated during the process and its suitability for CHP applications. Low temperature fuel cells generate a thermal product suitable for low pressure steam and hot water CHP applications. High temperature fuel cells produce high pressure steam that can be used in combined cycles and other CHP process applications. Although some fuel cells can operate at part load, other designs do not permit on/off cycling and can only operate under continuous base load conditions.

For stationary power, fuel cells are being developed for small commercial and residential markets and as peak shaving units for commercial and industrial customers.

In a unique innovation, high temperature fuel cells and gas turbines are being integrated to boost electric generating efficiencies. Combined cycle systems are being evaluated for sizes up to 25 MW with electric efficiencies of 60-70% (LHV). The hot exhaust from the fuel cell is combusted and used to drive the gas turbine. Energy recovered from the turbine's exhaust is used in a recuperator that preheats air from the turbine's compressor section. The heated air is then directed to the fuel cell and the gas turbine. Any remaining energy from the turbine exhaust can be recovered for CHP.

Technology Advancements

With the exception of PAFC, fuel cell technology is still being demonstrated in the field or in the laboratory. Significant development and funding will be required over the next 5-10 years to achieve projected performance and cost. Major activities include reformer design, size reduction and improved manufacturing techniques. Collaboration between industry and government has been an important factor in sustaining development efforts.

Development in the mobile market should have a major impact on fuel cell technology. It is anticipated that PEM technology will be demonstrated by the year 2000.

6. System Issues

Integrating a CHP technology with a specific application together as a system, requires an understanding of the engineering and site-specific criteria that will provide the most economic solution. The final design must address siting issues like noise abatement and footprint constraints. Engineering information for designing a technically and economically feasible system should include electric and thermal load profiles, capacity factor, fuel type, performance characteristics of the prime mover, etc. CHP by definition implies the simultaneous generation of two or more energy products that function as a system. This section of the report reviews some of the primary issues faced by the design engineer in selecting and designing a CHP system.

Electric and Thermal Load Profiles

One of the first and most important elements in the analysis of CHP feasibility is obtaining accurate representations of electric and thermal loads. This is particularly true for load following applications where the prime mover must adjust its electric output to match the demand of the end-user while maintaining zero output to the grid. A 30-minute or hourly load profile provides the best results for such an analysis. Thermal load profiles can consist of hot water use, low and high pressure steam consumption and cooling loads. The shape of the electric load profile and the spread between minimum and maximum values will largely dictate the number, size and type of prime mover. It is recommended that electric and thermal loads be monitored if such information is not available.

For base load CHP applications that export power to the grid and meet a minimum thermal load required under PURPA, sizing a CHP facility is largely dictated by capacity requirements in the wholesale energy market. Rather than meeting the demand of an end-user, such plants are dispatched to the grid along with other generating systems as a function of cost of generation.

Capacity factor is a key indicator of how the capacity of the prime mover is utilized during operation. Capacity factor is a useful means of indicating the overall economics of the CHP system. The capacity factor indicates the facility's proximity to baseload operation. Capacity factor is defined as follows:

$$\text{Capacity Factor} = \frac{\text{Actual Energy Consumption}}{\text{Peak Capacity of Prime Mover} \times 8,760 \text{ hours}}$$

A low capacity factor is indicative of peaking applications that derive economic benefits generally through the avoidance of high demand charges. A high capacity factor is desirable for most CHP applications to obtain the greatest economic benefit. A high capacity factor effectively reduces the fixed unit costs of the system (\$/kWh) and increases the generator's ability to remain competitive with grid supplied power.

Gas turbines are typically selected for applications with relatively constant electric load profiles to minimize cycling the turbine or operating the turbine for a large percentage of hours at part load conditions where efficiency declines rapidly. Gas turbines are ideal for industrial or institutional end-users with 24 hour operations or where export to the grid is intended.

Most commercial end-users have a varying electric load profile, i.e., high peak loads during the day and low loads after business hours at night. Natural gas reciprocating engines are a popular choice for commercial CHP due to good part-load operation, ability to obtain an air quality permit and availability of size ranges that match the load of many commercial and institutional end-users. Reciprocating engines exhibit high electric

efficiencies meaning that there is less available rejected heat. This is often compatible with the thermal requirements of the end-user.

Micro-turbines are just emerging as a as a future distributed resource that will be ideally sized to meet the electric load profiles of many commercial and institutional end-users. Exhaust heat can be recovered for hot water or steam loads.

Thermal demand of a commercial or institutional end-user often consists of hot water or low pressure steam demand in the winter and a cooling demand in the summer. Heat from the prime movers often used in a single-stage steam or hot water absorption chiller. This option allows the CHP system to operate continuously throughout the year while maintaining a good thermal load without the need to reject heat to the environment.

Quality of Recoverable Heat

The thermal requirements of the end-user may dictate the feasibility of a CHP system or the selection of the prime mover. Gas turbines offer the highest quality heat that is often used to generate power in a steam turbine. Gas turbines reject heat almost exclusively in its exhaust gas stream. The high temperature of this exhaust can be used to generate high pressure steam or lower temperature applications such as low pressure steam or hot water. Larger gas turbines (typically above 25 MW) are frequently used in combined cycles where high pressure steam is produced in the HRSG and is used in a steam turbine to generate additional electricity. The high levels of oxygen present in the exhaust stream allows for supplemental fuel addition to generate additional steam at high efficiency.

Some of the developing fuel cell technologies including molten carbonate fuel cells (MCFC) and solid oxide fuel cells (SOFC) will also provide high quality rejected heat comparable to a gas turbine.

Reciprocating engines and the commercially available phosphoric acid fuel cell (PAFC) produce a lower grade of rejected heat, therefore heating applications that require low pressure steam (15 psig) or hot water are most suitable for these technologies. The exhaust from a reciprocating engine can generate steam up to 100 psig.

Reciprocating engines typically have a higher efficiency than most gas turbines in the same output range and are a good fit where the thermal load is low relative to electric demand. Reciprocating engines can produce low and high pressure steam from its exhaust gas, although low pressure steam or hot water is generally specified. Jacket water temperatures are typically limited to 210F so that jacket heat is usually recovered in the form of hot water. All the jacket heat can be recovered if there is sufficient demand, however, only 40-60% of the exhaust heat can be recovered to prevent condensation of corrosive exhaust products in the stack that will limit equipment life.

Noise

Although fuel cells are relatively expensive to install, they are being tested in a number of sites typically where the cost of a power outage is significant to lost revenues or lost productivity and where uninterrupted power is mandatory. Their relatively quiet

operation has appeal and these units are being installed in congested commercial areas. Locating a turbine or engine in a residential area usually requires special consideration and design modifications to be acceptable.

Engine and turbine installations are often installed in building enclosures to attenuate noise to surrounding communities. Special exhaust silencers or mufflers are typically required on exhaust stacks. Gas turbines require a high volume of combustion air, causing high velocities and associated noise. Inlet air filters can be fitted with silencers to substantially reduce noise levels.

Gas turbines are more easily confined within a factory supplied enclosure than reciprocating engines. Reciprocating engines require greater ventilation due to radiated heat that makes their installation in a sound-attenuating building often the most practical solution. Gas turbines require much less ventilation and can be concealed within a compact steel enclosure.

Foot Print

Phosphoric acid fuel cells and micro-turbines offer compact packaging and have an appeal to those end-users that are seeking a non-obtrusive power generation or CHP system. Larger gas turbines and reciprocating engines generally are isolated in either a factory enclosure or a separate building along with ancillary equipment.

Fuel Supply

A potential system issue for gas turbines is the supply pressure of the natural gas distribution system at the end-user's property line. Gas turbines need minimum gas pressures of about 120 psig for small turbines with substantially higher pressures for larger turbines. Assuming there is no high pressure gas service, the local gas distribution company would have to construct a high pressure gas line or the end-user must purchase a gas compressor. The economics of constructing a new line must consider the volume of gas sales over the life of the project.

Gas compressors may have reliability problems especially in the smaller size ranges. If "black start" capability is required, then a reciprocating engine may be needed to turn the gas compressor, adding cost and complexity.

Reciprocating engines and fuel cells are more accommodating to the fuel pressure issue, generally requiring under 50 psig. Reciprocating engines operating on diesel fuel storage do not have fuel pressure as an issue, however, there may be special permitting requirements for on-site fuel storage.

Diesel engines should be considered where natural gas is not available or very expensive. Diesel engines have excellent part load operating characteristics and high power densities. In most localities, environmental regulations have largely restricted their use for CHP. In California and elsewhere in the U.S., diesel engines are almost exclusively used for emergency power or where uninterrupted power supply is needed such as in hospitals and

critical data operating centers. As emergency generators, diesel engines can be started and achieve full power in a relatively short period of time.

