

Vehicles and Agriculture Energy

“Well Beyond Tune-Ups”

John Lumkes
Agricultural and Biological Engineering
Purdue University – West Lafayette, IN



ACEEE Forum



Outline

- Overview
- New Driveline Technologies
 - Hybrid Drivetrains
 - Valveless Electrohydraulics
- New Engine Technologies
 - Camless Engines
- Tying it all Together
 - Design and Simulation of “Systems”
 - Biofuels and more



ACEEE Forum



Long Term Goals

- Technologies for autonomous – robot like multifunctional mobile machines and off road vehicles
 - Energy efficient
 - Environmental friendly
 - Smart and reliable
- For agricultural & construction machines and other applications



ACEEE Forum



Humanity's Top Ten Problems for next 50 years

1. ENERGY
2. WATER
3. FOOD
4. ENVIRONMENT
5. POVERTY
6. TERRORISM & WAR
7. DISEASE
8. EDUCATION
9. DEMOCRACY
10. POPULATION

Source: R. E. Smalley, Rice University

2003 6.3 Billion People
2050 8-10 Billion People



ACEEE Forum



Energy Trends in Consumption

- Good News:
 - From 1850 to 1970: population tripled, energy 12-fold.
 - From 1970 to present: population up 68%, energy use up 73%.
 - (State of the World Report, Worldwatch Institute 2004)
- Bad News:
 - Population, and therefore total energy use, continues to rise.
 - In the production of food, only 10-20% of the input energy is in production; 80-90% is in transportation, processing, and consumption (Heller and Kaoleian)
 - In 1992, China and India averaged 0.7 barrels of oil/person/yr.
 - In 1992, US averaged 22.5 barrels of oil/person/yr.

Source: Energy Information Administration, Annual Energy Review 2004



ACEEE Forum



Trends in Consumption of Petroleum

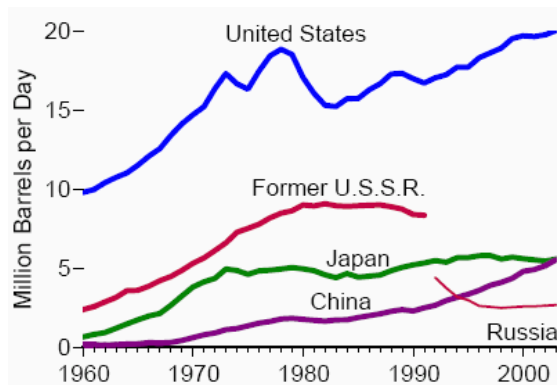

Source: Energy Information Administration, Annual Energy Review 2004



ACEEE Forum



Outline

- Overview
- **New Driveline Technologies**
 - Hybrid Drivetrains
 - Valveless Electrohydraulics
- New Engine Technologies
 - Camless Engines
- Tying it all Together
 - Design and Simulation of “Systems”
 - Biofuels and more



ACEEE Forum



Recent Trends in Transportation (Will it influence agriculture?)

- Resurgence of Hybrid Vehicles
 - Prius, Insight, Escape, HLA, Cumulo
- Emphasis on Fuel Cells
- Clean Diesel Technologies
- New Engine Technologies
- Increased Emphasis on Biofuels



ACEEE Forum



General Characteristics of Hybrid Transmissions

- Potential Benefits (Assuming Energy Storage)
 - Regenerative Braking
 - Engine/Road Load Decoupling
- Competing Technologies offer...
 - High Power Densities: Electrohydraulics, Ultracapacitors
 - High Energy Densities: Batteries (Chemical) and Flywheels
- Promises Include...
 - 20%-200% Improvement in MPG
 - Leads to Reduced Emissions
 - Improved Performance



ACEEE Forum



Hybrids—Current EH Activity

- EPA HHV Program
 - Diesel hydraulic hybrid
 - 55% improvement (projected)
- Research partnerships with:
 - Ford
 - Eaton
 - Army
 - Parker-Hannifin

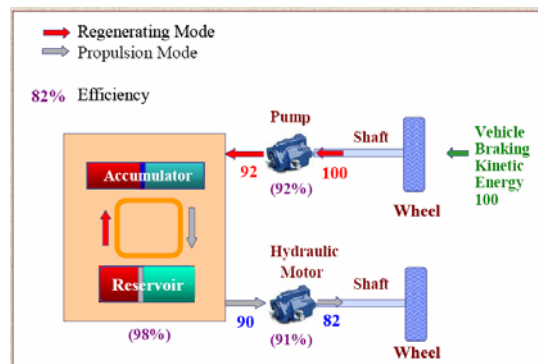

www.epa.gov/otaq/technology



ACEEE Forum



Hybrids—Current EH Activity

- Eaton: Hydraulic Launch Assist (HLA)
- Permo-Drive (similar concept)
 - Can be added as an accessory
 - Up to a 30% improvement in economy
 - 15-20% improvement in performance
 - Composite Accumulators, Integrated Electronics



ACEEE Forum



Advanced Energy Saving Actuator Technology (Valveless)

- Pump control instead valve control
 - Less fuel consumption
 - Less heat generation
 - Machine function via SW

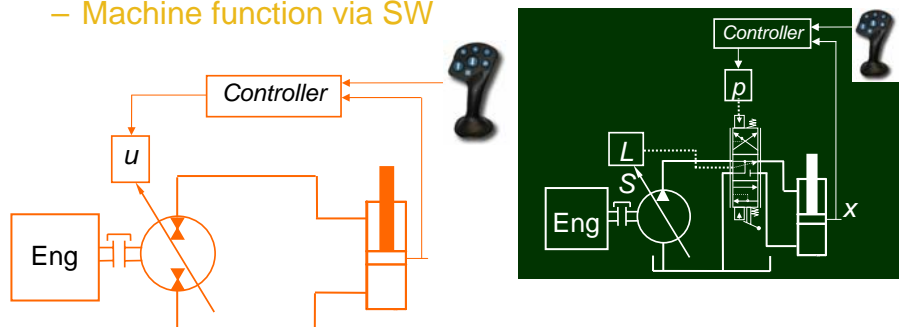

Source: Dr. Ivantysynova, Purdue

ACEEE Forum



Advanced Energy Saving Actuator Technology (Valveless)

- Implemented Successfully in Several Test Applications

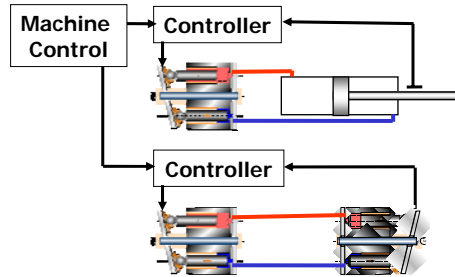

PURDUE
UNIVERSITY



Source: Dr. Ivantysynova, Purdue

ACEEE Forum



Outline

- Overview
- New Driveline Technologies
 - Hybrid Drivetrains
 - Valveless Electrohydraulics
- **New Engine Technologies**
 - Camless Engines
- Tying it all Together
 - Design and Simulation of “Systems”
 - Biofuels and more

PURDUE
UNIVERSITY



ACEEE Forum



New Engine Technologies

- Clean Diesel Technologies
 - Homogeneous Charge Compression Ignition
 - In-cylinder treatments
 - EGR, simulation of combustion, multiple injections of fuel (piezo drivers)
 - Post-combustion treatments
 - Catalysts
 - Particulate Traps
- Forced by layered regulations for on-road and off-road engine applications.



ACEEE Forum



Camless Engine Technologies

- Motivation
 - Environmental (Driven by new regulations)
 - Cost (Potential long-term cost savings?)
 - Estimated production of >40 million IC engines / year.
- Current Cam Driven Engines
 - Profile is optimized for one operating point.
- Camless Engines
 - Variable lift, timing, profile (dwell), cylinder deactivation, EGR, multiple fuels, and engine braking.
- Most Manufacturer's are using or considering VVA
 - VVA is different than camless, more limitations.
 - Most vary phase, some vary profile, some vary lift.



ACEEE Forum



Potential Benefits of Camless Engines

- Two Categories for Environmental Benefits
 - Reducing the Consumption of Fuel
 - Reducing the Harmful Emissions
- Possible Improvements to Engine Efficiencies
 - More valve overlap at high power levels
 - Less valve lift at lower engine speeds (better mixture)
 - Cylinder Deactivation
 - Engine Braking without added components
 - EGR capabilities for lower emissions
 - Optimization of engine for different fuels
 - Possible efficiency improvements of up to 20%
 - » SAE 890674



ACEEE Forum



Simulation Results—Variable Lift

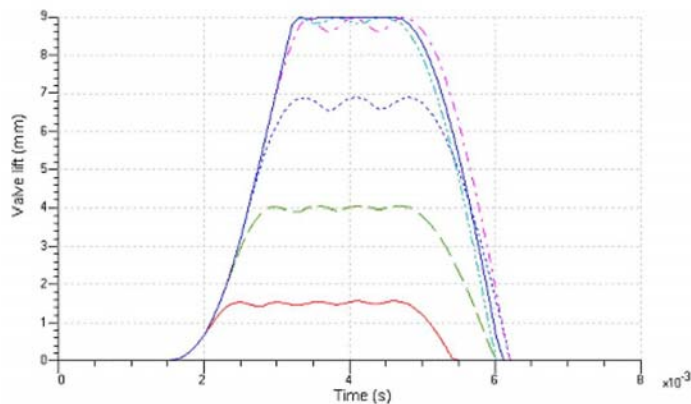

ACEEE Forum



Outline

- Overview
- New Driveline Technologies
 - Hybrid Drivetrains
 - Valveless Electrohydraulics
- New Engine Technologies
 - Camless Engines
- Tying it all Together
 - Design and Simulation of “Systems”
 - Biofuels and more



ACEEE Forum



Advanced Vehicle Drive Line Control Technologies

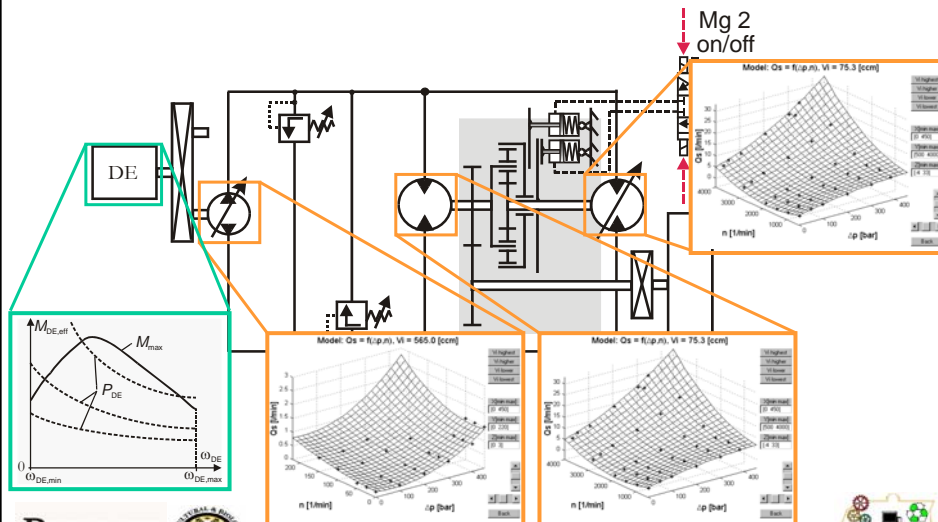

Source: Dr. Ivantysnova, Purdue

ACEEE Forum



Vehicle Driveline “Systems” Approach

- Most flexible
 - AWD
 - Traction Control
 - ABS
- More difficult to control (w/o accumulator)

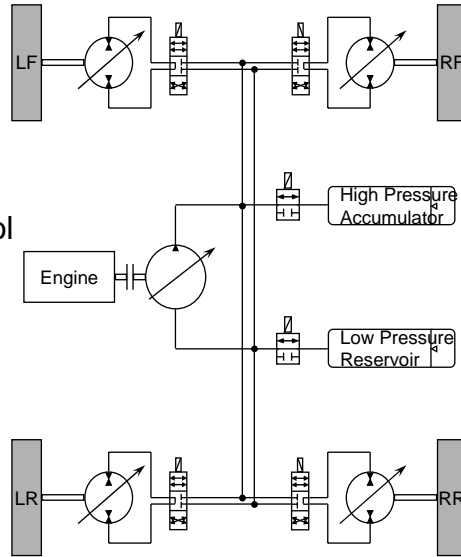

ACEEE Forum



Vehicle Controller Summary

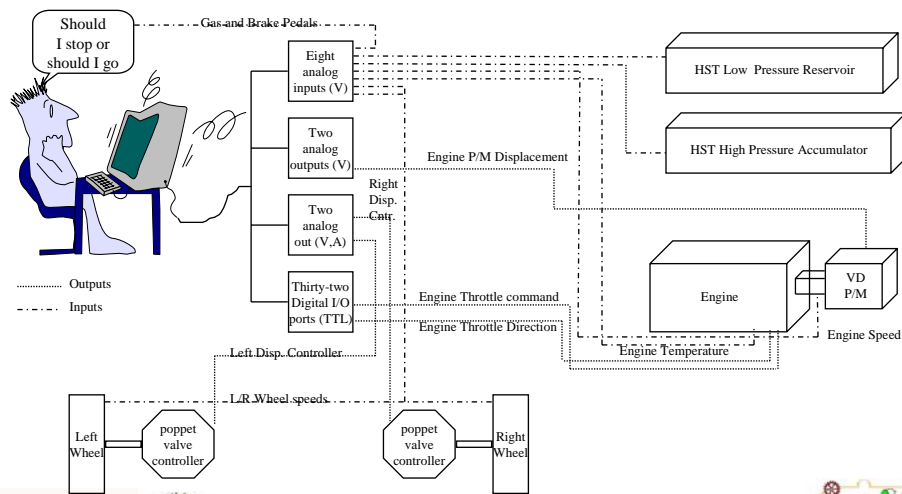

ACEEE Forum



Future Challenges

- Systems Approach to Emerging Technologies
 - Improving the efficiency, performance, and environmental impact of interacting systems.
 - Multiple machines, controllers, and components all interacting for the best "overall" performance.
 - From Nano and MEMS to Global.
- Increased use of Knowledge Transfer Technologies
 - Smart products, self-healing, maintenance alerts, national security, etc. (Cybernetics)
 - Computer chips embedded in more products
 - Configurable EH multi-purpose valve.
- Intelligent Sensors and Actuators (Distributed)
- Provides benefits to all fields (AG/Auto/Industrial/etc.)



ACEEE Forum



What about Renewable Energy?

- In the US, renewable fuels account for only 2% of energy used.
 - Oil currently accounts for 30%
 - But renewable sources are growing at 20-30% / year
 - 25% of Sweden's energy, 45% of Norway's energy
- Wind
 - Cost 46 cents/kWh in 1980, now less than 6 c/kWh
 - Total available estimated to be at 2-4 TW
- Geothermal Power
 - Total available over all the land area on earth ~12 TW
- Hydroelectric
 - Total remaining practical resources ~0.5 TW
 - Cumulative energy of all tides and ocean currents ~2 TW

Report on the Basic Sciences Energy Workshop, US DOE, 2005



ACEEE Forum



That leaves Solar Energy

- Categories: Electricity, Fuels (biomass), and Thermal
- Solar
 - 10% efficient “collectors” over 1.6% of US land area would supply the domestic needs.
 - About the area covered by the federal highway system.
 - About 0.16% of the land on earth would supply 20TW
 - More energy strikes the earth in one hour than what is consumed in one year.
 - Current solar electricity is 1 millionth of total used.
 - Renewable biomass about 0.1% of total used.

Report on the Basic Sciences Energy Workshop, US DOE, 2005



ACEEE Forum



The Future of Bio Fuels

- US produced 3.41 billion gallons of ethanol in 2004, a 21% increase from 2005 (Renewable Fuels Association)
 - Currently used in 12% of gasoline sold, accounting for ~ 1% by volume.
- Indiana Goals:
 - 200 million gallons of ethanol by 2007
 - 40 million gallons of biodiesel by 2007
 - 10% biofuels by 2007
 - 20% biofuels by 2025
- Daimler Chrysler, Ford, General Motors, Isuzu, Mazda, Mercedes, Mercury, and Nissan have E85 compatible models.



ACEEE Forum



The Future of Bio Fuels

- Advantages
 - Produces electricity and heat at comparable costs of fossil derived fuels.
 - Less reliance on imported energy.
- Disadvantages
 - Using switchgrass, all the arable land would only produce approximately 13 TW
 - Energy yield is dependent on many factors
 - And thus controversial...



ACEEE Forum



What About Hydrogen?

- The two most common elements in the Universe are hydrogen and stupidity.
 - Harlan Ellison
- "I believe that one day hydrogen and oxygen, which together form water, will be used either alone or together as an inexhaustible source of heat and light."
 - *The Mysterious Island* by Jules Verne, 1874



ACEEE Forum



The Future of Fuel Cells

- What must be done to achieve a “hydrogen economy”?
 - Advancements in Fuel Cell costs, operating ranges, and efficiencies.
 - The development of a hydrogen infrastructure.
 - A source of hydrogen?
 - Storage of hydrogen?
 - Liquid hydrogen is $\sim\frac{1}{4}$ the energy density of gasoline.



ACEEE Forum



The Future of Fuel Cells

- A source of hydrogen?
 - Steam reformers (need natural gas or methane)?
 - Byproduct is carbon monoxide
 - Coal gasification for fuel?
 - Electrolysis (needs electricity)?
 - Organic methods?
 - Chemical methods?



ACEEE Forum



What is the Conclusion?

- Now is a great time to be an engineer or scientist!
- Solutions need to be
 - Multidisciplinary
 - Approached as Systems (integration of many factors)
 - Short term leading to long term sustainability
- Improvements in and Utilization of Every Option is the Only Way.



Be a Steward!

ACEEE Forum



**Thank you for your Time.
Any Questions?**

Contact Information:
lumkes@purdue.edu



ACEEE Forum

